


***BRENT*** Grain Handling

CORNER-AUGER GRAIN CART  
MODELS V1300 / V1500

Serial Number B45580100 & Higher

Part Number 297936

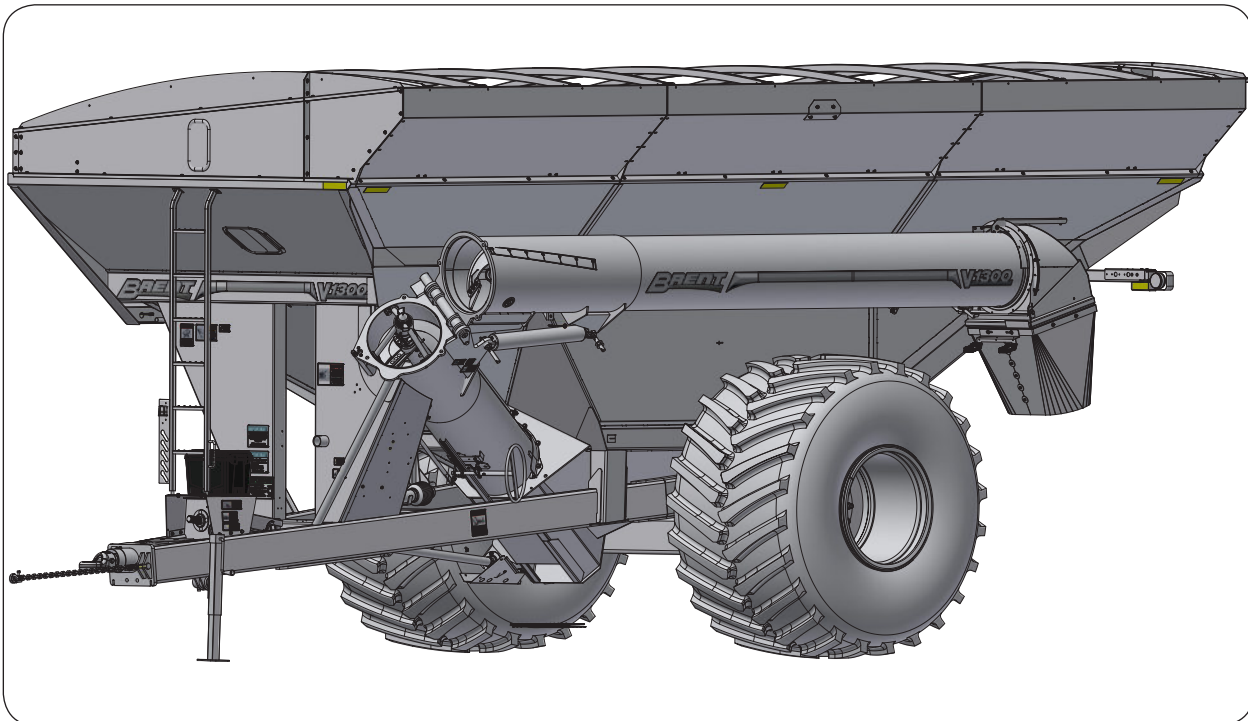
## **Foreword**

 This symbol identifies important safety messages. When you see it, read the message that follows and be alert to the possibility of personal injury.

Remember, safety instructions stated in this manual are for your protection. Read them carefully and follow them closely when working around or using this machine.

Read and study this manual completely before attempting to operate this implement. Take this manual to the field for handy reference when operating, adjusting, or servicing your machine.

When referenced, “Right-Hand” (RH) and “Left-Hand” (LH) side of the machine are determined by standing behind the machine and facing in the direction of travel.





## Product Information

When ordering parts or when requesting further information or assistance, always give the following information:

- Machine name
- Model
- Serial Number

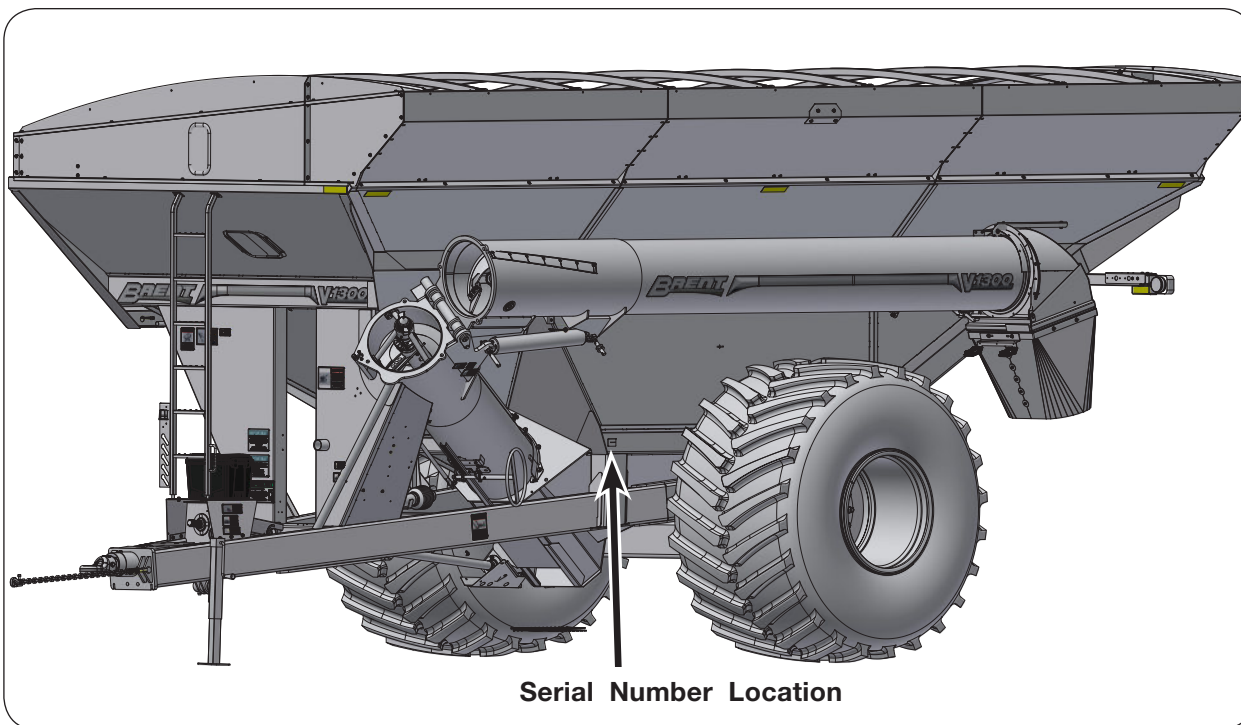
All products manufactured by Unverferth Mfg. Co., Inc. are warranted to be free from material and workmanship defects for one full year from time of consumer delivery. Your local dealer will gladly assist you with any warranty questions.

Please fill out and retain this portion for your records. The serial number plate is located on the frame as shown below.

Purchase Date \_\_\_\_\_ Model \_\_\_\_\_ Serial Number \_\_\_\_\_

Dealer \_\_\_\_\_ City \_\_\_\_\_

Dealer Contact \_\_\_\_\_ Phone \_\_\_\_\_



### IMPORTANT

- *The information, specifications, and illustrations in the manual are based on information available at the time it was written. Due to continuing improvements in the design and manufacture of Unverferth products, all specifications and information contained herein are subject to change without notice.*

**Table of Contents**

**Section I  
Safety**

General Hazard Information .....	1-2
Safety Decals .....	1-3
Following Safety Instructions .....	1-5
Before Servicing or Operating .....	1-6
During Operation .....	1-6
Before Transporting .....	1-7
During Transport .....	1-7
Driveline Safety .....	1-8
Pressurized Oil .....	1-9
Preparing for Emergencies .....	1-10
Wearing Protective Equipment .....	1-10

**Table of Contents**

**Section II  
Set Up**

Set Up Checklist..... 2-2  
Set Up..... 2-3  
SMV Emblem & SIS Decal ..... 2-4  
Auger Rest Retainer Removal..... 2-5  
Jack and Optional Hydraulic Jack ..... 2-6  
    Jack..... 2-6  
    Install Hydraulic Jack (Optional)..... 2-6  
Lamp Set Up ..... 2-8  
Driveline ..... 2-8  
Wheel & Tire Set Up..... 2-9  
    Tire Pressure ..... 2-9  
    Wheel Nuts..... 2-9  
Spindle Positioning..... 2-10  
Sideboards and End Caps ..... 2-11  
Tarp Installation..... 2-22  
Operational Checklist ..... 2-27

FOR SCALE, TRACK, UHARVEST, HYDRAULIC DRIVE, ELECTRIC TARP, AND / OR WATER DELIVERY SYSTEM INFORMATION, PLEASE REFER TO THE INDIVIDUAL MANUALS.

**Table of Contents**

**Section III  
Operation**

Operating Checklist..... 3-2  
Preparing Tractor..... 3-2  
Preparing Cart..... 3-3  
    Hardware ..... 3-3  
    Pivot Pins ..... 3-3  
    Hitch ..... 3-3  
    Auger ..... 3-3  
    Auger Driveline Assembly..... 3-4  
    Soft Start System..... 3-4  
    Hydraulic System..... 3-4  
    Tires/Wheels..... 3-4  
Lubrication..... 3-4  
Hitching to Tractor ..... 3-5  
    Drawbar Connection ..... 3-5  
    Jack Usage..... 3-6  
    Optional Hydraulic Jack Usage ..... 3-7  
    Transport Chain Connection..... 3-8  
    Hydraulic Connections for Hydraulic Drive..... 3-9  
    Hydraulic Connections ..... 3-9  
    Hydraulic Connections for Optional Water Delivery System ..... 3-10  
    Electrical Connections..... 3-11  
Electric Over Hydraulic Operation - 4 Function (Optional) ..... 3-12  
Cart Loading Sequence..... 3-15  
Towing..... 3-16  
Auger Operation ..... 3-17  
Rear Ladder Operation..... 3-19  
Rear Access Door Operation..... 3-21  
Weather Guard Tarp..... 3-22  
    Electric Tarp Wireless Receiver and Control Box Location ..... 3-24

FOR SCALE, TRACK, UHARVEST, HYDRAULIC DRIVE, ELECTRIC TARP, AND / OR WATER DELIVERY SYSTEM INFORMATION, PLEASE REFER TO THE INDIVIDUAL MANUALS.

**Table of Contents**

**Section IV  
Maintenance**

Lubrication..... 4-2

Gearbox Lubrication ..... 4-3

Hydraulic System ..... 4-4

    Purge Hydraulic System ..... 4-4

Manual Override for Optional Electric Over Hydraulic System ..... 4-5

Auger System..... 4-8

    Lower Auger ..... 4-8

        Lower Auger Removal..... 4-8

        Lower Auger Assembly ..... 4-9

        Hanger Bearing Centering..... 4-10

        Lower Auger Timing..... 4-10

        U-Joint Spline Gap..... 4-11

    Upper Auger..... 4-12

        Upper Auger Removal ..... 4-12

        Soft Start Replacement..... 4-13

        Upper Auger Timing ..... 4-13

        Upper Auger Height ..... 4-15

        Upper Auger Bearing Gap ..... 4-16

        Auger Flow Door Cylinder Replacement ..... 4-17

        Auger Floor Door Cylinder Stop..... 4-20

Auger Driveline..... 4-21

Adjusting Cleanout Door ..... 4-27

Verify Telescoping PTO Shaft Length ..... 4-29

PTO Shaft and Clutch..... 4-31

PTO Quick Disconnect ..... 4-34

Wheels, Hub and Disassembly and Assembly..... 4-35

Wheels and Tires - Wheel Nut Torque ..... 4-37

Wheels and Tires - Tire Pressure..... 4-38

Wheels and Tires - Tire Warranty..... 4-39

Seasonal Storage ..... 4-40

Hydraulic Jack Cylinder Replacement..... 4-42

Troubleshooting..... 4-44

Tarp Troubleshooting Inspection & Maintenance ..... 4-46

Electrical System Diagram..... 4-47

Hydraulic System Plumbing Diagram..... 4-58

Torque Chart - Hardware ..... 4-59

Hydraulic Fittings - Torque and Installation ..... 4-61

FOR SCALE, TRACK, UHARVEST, HYDRAULIC DRIVE, ELECTRIC TARP, AND / OR WATER DELIVERY SYSTEM INFORMATION, PLEASE REFER TO THE INDIVIDUAL MANUALS.

**Table of Contents**

**Section V  
Parts**

**For the most current parts listing, please visit: [www.unverferth.com/parts](http://www.unverferth.com/parts)**

Decals .....	5-2
Final Assembly .....	5-4
Hopper Cross Brace Components.....	5-6
Clean Out Door Assembly.....	5-7
Flow Door Seals .....	5-8
Directional Spout.....	5-10
Wheel Well Cover Kit (V1300 Only) .....	5-14
Wheel Well Cover Kit (V1500 Only) .....	5-15
Rear Ladder Components .....	5-16
Rear Access Door Components .....	5-17
Sideboards.....	5-18
Single Wheel Axle (V1300 Only).....	5-20
Single Wheel Axle (V1500 Only).....	5-22
Track Axle (V1300 Only).....	5-24
Track Axle (V1500 Only).....	5-25
Driveline Components.....	5-26
Driveline U-Joint Assembly - For SN B45970100 & Higher .....	5-28
Driveline U-Joint Assembly - For SN B45970099 & Lower.....	5-29
Single Wheels and Tires.....	5-30
Touch Up Paint.....	5-30
Upper Auger Components .....	5-32
Lower Auger Components.....	5-34
PTO Cut Out Clutch Components (Benzi America).....	5-36
PTO Components (Benzi America) .....	5-37
45 Degree Gearbox.....	5-38
Cylinders.....	5-40
Hydraulics.....	5-42
EOH Tractor Hydraulic Components (Optional).....	5-45
EOH Valve Assembly Components (4 Spool) (Optional).....	5-46
Electrical.....	5-48
Weather Guard Tarp.....	5-50
Video System Option .....	5-53
Hydraulic Jack- Kit #294143B (Optional).....	5-54

FOR SCALE, TRACK, UHARVEST, HYDRAULIC DRIVE, ELECTRIC TARP, AND / OR WATER DELIVERY SYSTEM INFORMATION, PLEASE REFER TO THE INDIVIDUAL MANUALS.

# **Section I Safety**

General Hazard Information .....	1-2
Safety Decals .....	1-3
Following Safety Instructions .....	1-5
Before Servicing or Operating .....	1-6
During Operation .....	1-6
Before Transporting .....	1-7
During Transport .....	1-7
Driveline Safety .....	1-8
Pressurized Oil .....	1-9
Preparing for Emergencies .....	1-10
Wearing Protective Equipment .....	1-10

## General Hazard Information

No accident-prevention program can be successful without the wholehearted cooperation of the person who is directly responsible for the operation of the equipment.

A large number of accidents can be prevented only by the operator anticipating the result before the accident is caused and doing something about it. No power-driven equipment, whether it be transportation or processing, whether it be on the highway, in the field, or in the industrial plant, can be safer than the person who is at the controls. If accidents are to be prevented--and they can be prevented--it will be done by the operators who accept the full measure of their responsibility.

It is true that the designer, the manufacturer, and the safety engineer can help; and they will help, but their combined efforts can be wiped out by a single careless act of the operator.

It is said that, "the best kind of a safety device is a careful operator." We, at Unverferth Mfg. Co., Inc. ask that you be that kind of operator.



**REMEMBER:**  
**THINK SAFETY**  
A CAREFUL OPERATOR IS THE  
BEST INSURANCE AGAINST AN  
ACCIDENT!

### SIGNAL WORDS



INDICATES AN EXTREMELY HAZARDOUS SITUATION OR ACTION THAT WILL RESULT IN SERIOUS INJURY OR DEATH.



INDICATES A HAZARDOUS SITUATION OR ACTION THAT COULD RESULT IN SERIOUS INJURY OR DEATH.



INDICATES AN UNSAFE SITUATION OR ACTION THAT MAY RESULT IN PERSONAL INJURY.



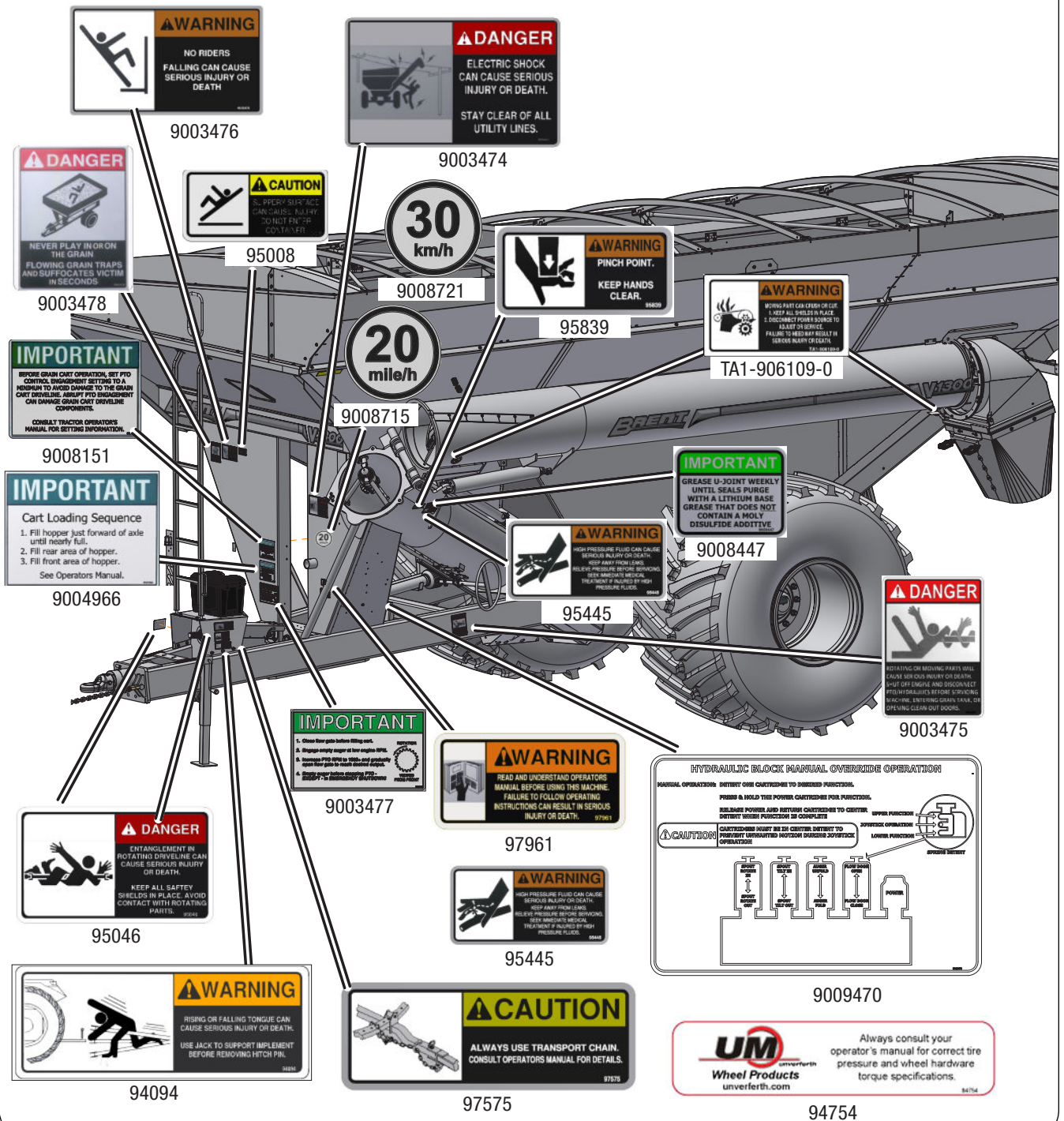
*Is used for instruction on operating, adjusting, or servicing a machine.*



Safety Decals

**WARNING**

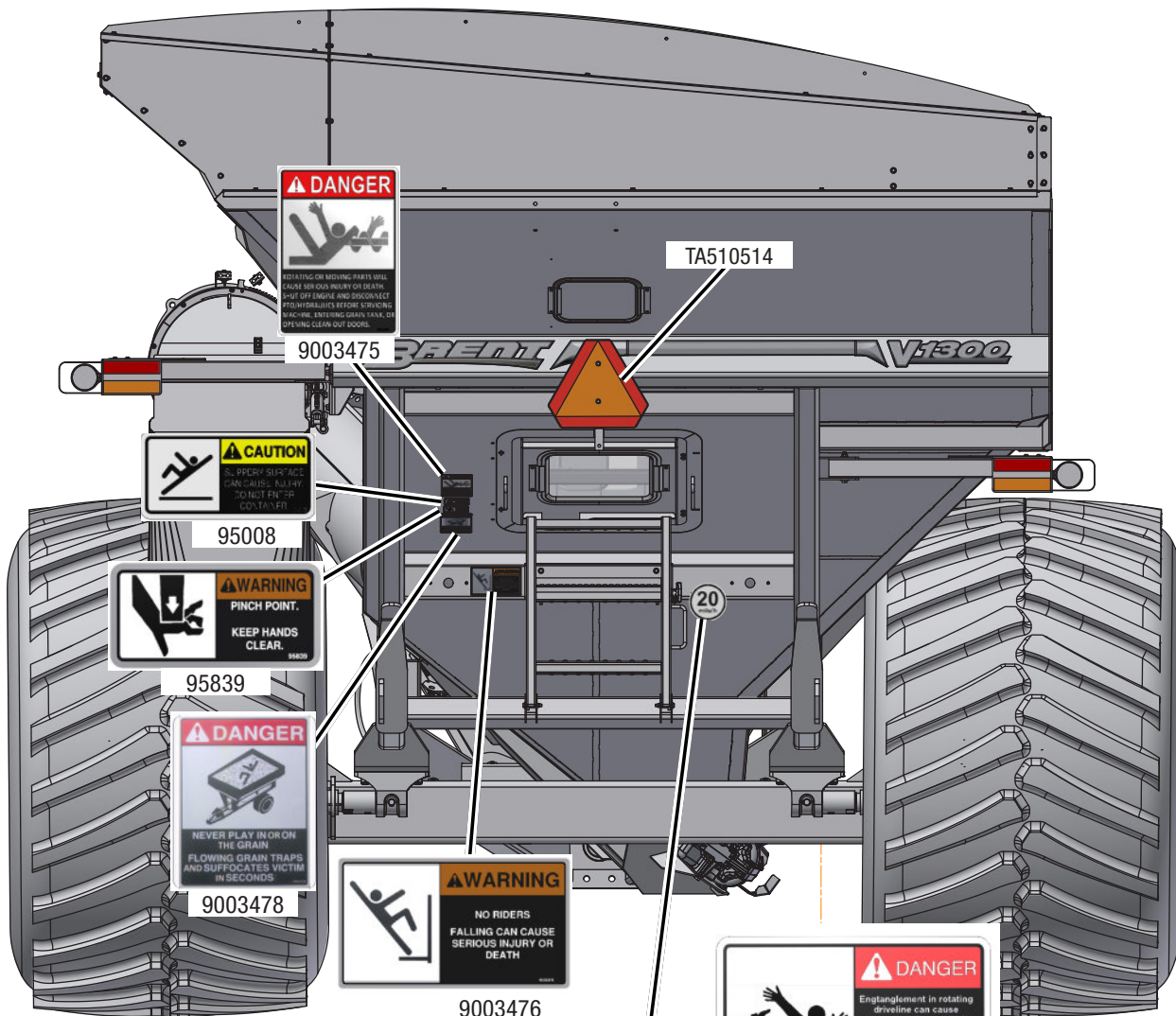
- REPLACE LOST, DAMAGED, PAINTED, OR UNREADABLE DECALS IMMEDIATELY. IF PARTS THAT HAVE DECALS ARE REPLACED, ALSO MAKE SURE TO INSTALL NEW DECALS. THESE DECALS INFORM AND REMIND THE OPERATOR WITH OPERATIONAL INFORMATION AND SAFETY MESSAGES.



**UM** unverferth  
**Wheel Products**  
 unverferth.com

Always consult your operator's manual for correct tire pressure and wheel hardware torque specifications.

Safety Decals (continued)



PART NO. 9003125  
FLUORESCENT STRIP



PART NO. 9003126  
REFLECTOR RED



PART NO. 9003127  
REFLECTOR AMBER



9008714



9008720



95046

## **Following Safety Instructions**

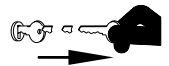
- Read and understand this operator's manual before operating.



- All machinery should be operated only by trained and authorized personnel.

- To prevent machine damage, use only attachments and service parts approved by the manufacturer.

- Always shut tractor engine off and remove key before servicing.



- Avoid personal attire such as loose fitting clothing, shoestrings, drawstrings, pants cuffs, long hair, etc., that may become entangled in moving parts.

- Do not allow anyone to ride on the implement. Make sure everyone is clear before operating machine or towing vehicle.






- Never attempt to operate implement unless you are in the driver's seat.

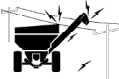
- Never enter a cart containing grain. Flowing grain traps and suffocates victims in seconds.



## Before Servicing or Operating

- Avoid working under an implement; however, if it becomes absolutely unavoidable, make sure the implement is safely blocked. 
- Ensure that all applicable safety decals are installed and legible.
- When working around the implement, be careful not to be cut by sharp edges.
- To prevent personal injury or death, always ensure that there are people who remain outside the cart to assist the person working inside, and that all safe workplace practices are followed. There are restricted mobility and limited exit paths when working inside the implement.
- Secure drawbar pin with safety lock and lock tractor drawbar in fixed position.
- Explosive separation of a tire and rim can cause serious injury or death. Only properly trained personnel should attempt to service a tire and wheel assembly.
- Add sufficient ballast to tractor to maintain steering and braking control at all times. Do not exceed tractor's lift capacity or ballast capacity.
- Do not stand between towing vehicle and implement during hitching. 
- Always make certain everyone and everything is clear of the machine before beginning operation.
- Verify that all safety shields are in place and properly secured. 
- Ensure that all applicable safety decals are installed and legible.
- When working around the implement, be careful not to be cut by sharp edges.

## During Operation

- Regulate speed to working conditions. Maintain complete control at all times.
- Never service or lubricate equipment when in operation.
- Keep away from overhead power lines. Electrical shock can cause serious injury or death. 
- Use extreme care when operating close to ditches, fences, or on hillsides.
- Do not leave towing vehicle unattended with engine running.

### **Before Transporting**

- Verify transport chain capacity meets or exceeds weight capacity of all towed implements. Secure transport chains to towing vehicle before transporting. **DO NOT** transport without chains.
- Check for proper function of all available transport lights. Make sure that all reflectors are clean and in place on machine. Make sure the SMV emblem and SIS decals are visible to approaching traffic.
- This implement is not equipped with brakes. Ensure that the towing vehicle has adequate weight and braking capacity to tow this unit.

### **During Transport**

- Comply with all laws governing highway safety when moving machinery.
- Use transport lights as required by all laws to adequately warn operators of other vehicles.
- Regulate speed to road conditions and maintain complete control.
- Maximum transport speed of this implement should never exceed 20 m.p.h. as indicated on the machine. Maximum transport speed of any combination of implements must not exceed the lowest specified speed of the implements in combination. Do not exceed 10 m.p.h. during off-highway travel.
- Slow down before making sharp turns to avoid tipping. Drive slowly over rough ground and side slopes.
- Do not transport grain cart on roads while loaded.
- It is probable that this implement is taller, wider and longer than the towing vehicle. Become aware of and avoid all obstacles and hazards in the travel path of the equipment, such as power lines, ditches, etc.

## **Driveline Safety**

- Do not allow children near equipment that is running or engaged.




- Do not exceed 1000 rpm PTO speed.
- Disengage the PTO, stop the tractor engine, and remove key from ignition before making inspections, or performing maintenance and repairs.
- Inspect the driveline, quick disconnect, overload shear-bolt limiter or clutch, and shielding often. Repair immediately. Use replacement parts and attaching hardware equivalent to the original equipment. Only alterations described in this manual for overall length adjustment are allowed. Any other alteration is prohibited.
- Avoid excessively long hardware or exposed and protruding parts which can snag and cause entanglement.
- Lubricate the driveline as recommended in the MAINTENANCE section.
- Keep hoses, wiring, ropes, etc. from dangling too close to the driveline.
- Install driveline and shields according to recommended lengths and attaching methods with recommended hardware. The driveline shield should rotate independently a full rotation and telescope freely. The retaining chain must be secured to the implement safety shield.
- Adjust drawbar to height and length recommended in the OPERATION section.
- Use caution when turning to avoid contact between tractor tires and driveline.
- Check the length of the telescoping members to ensure the driveline will not bottom out or separate when turning and/or going over rough terrain. Refer to “PTO Shaft Length Adjustment” in MAINTENANCE section.
- Proper extended and collapsed lengths of the telescoping PTO shaft must be verified before first operation with each and every tractor. If the extended length of the PTO shaft is insufficient, it may become uncoupled or bottom out when turning and/or going over rough terrain which will cause serious injury or death from contact with uncontrolled flailing of PTO shaft assembly components.



## **Pressurized Oil**

- Relieve the hydraulic system of all pressure before adjusting or servicing. See hydraulic power unit manual for procedure to relieve pressure.

---

- High-pressure fluids can penetrate the skin and cause serious injury or death. Leaks of high-pressure fluids may not be visible. Use cardboard or wood to detect leaks in the hydraulic system. Seek medical treatment immediately if injured by high-pressure fluids. 

---

- Hydraulic system must be purged of air before operating to prevent serious injury or death.

---

- Do not bend or strike high-pressure lines. Do not install bent or damaged tubes or hoses.

---

- Repair all oil leaks. Leaks can cause fires, personal injury, and environmental damage.

---

- Route hoses and lines carefully to prevent premature failure due to kinking and rubbing against other parts. Make sure that all clamps, guards and shields are installed correctly.

---

- Check hydraulic hoses and tubes carefully. Replace components as necessary if any of the following conditions are found:
  - End fittings damaged, displaced, or leaking.
  - Outer covering chafed/cut or wire reinforcing exposed.
  - Outer covering ballooning locally.
  - Evidence of kinking or crushing of the flexible part of a hose.

### Preparing for Emergencies

- Keep a first aid kit and properly rated fire extinguisher nearby.



- Keep emergency numbers for fire, rescue, and poison control personnel near the phone.



### Wearing Protective Equipment

- Wear clothing and personal protective equipment appropriate for the job.



- Wear steel-toed shoes when operating.



- Wear hearing protection when exposed to loud noises.



- Do not wear additional hearing impairing devices such as radio headphones, etc.





## **Section II Set Up**

Set Up Checklist.....	2-2
Set Up.....	2-3
SMV Emblem & SIS Decal.....	2-4
Auger Rest Retainer Removal.....	2-5
Jack and Optional Hydraulic Jack .....	2-6
Jack.....	2-6
Install Hydraulic Jack (Optional).....	2-6
Lamp Set Up .....	2-8
Driveline .....	2-8
Wheel & Tire Set Up.....	2-9
Tire Pressure .....	2-9
Wheel Nuts.....	2-9
Spindle Positioning.....	2-10
Sideboards and End Caps.....	2-11
Tarp Installation.....	2-22
Operational Checklist .....	2-27

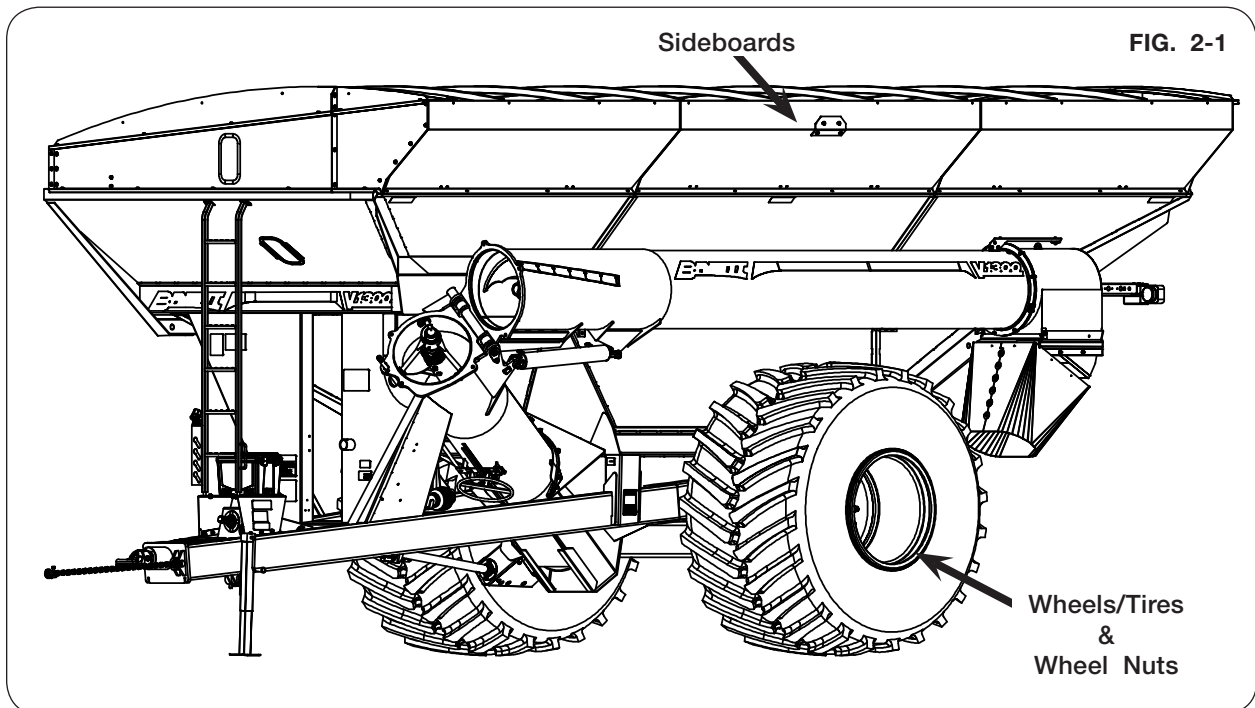
FOR SCALE, TRACK, UHARVEST, HYDRAULIC DRIVE, ELECTRIC TARP, AND / OR WATER DELIVERY SYSTEM INFORMATION, PLEASE REFER TO THE INDIVIDUAL MANUALS.

### Set Up Checklist

After the cart has been completely assembled, use the following checklist and inspect the cart. Check off each item as it is found satisfactory or after proper adjustment is made.

- Wash the unit and remove road salt tag #255000 from ladder.
- Remove auger rest retainer.
- Set or Calibrate tractor PTO control engagement to MINIMUM setting. Refer to tractor operator's manual for setting information.
- Complete sideboard and tarp set up. Remove tarp/sideboard shipping brackets.
- Reposition spindles from transport position to operating position. Refer to "Spindle Positioning".
- Torque wheel nuts as specified in MAINTENANCE section.
- Verify track has been aligned and is properly conditioned. (If Applicable)
- Check tire pressure and inflate tires as needed to specified air pressure. See "Tire Pressure" in MAINTENANCE section. (If applicable)
- Lubricate all grease fittings and check gearbox oil level.
- Check cleanout door assembly for play or movement.
- Verify all safety decals are correctly located and legible. Replace if damaged.
- Verify all reflective decals are correctly located.
- Check SMV decal and SIS decals are in place and, if necessary, remove shipping film.
- Verify transport lights are in working position and function properly.
- Verify driveline assembly phasing, see "Auger Driveline Assembly" in OPERATION section.
- Verify PTO length, see "Verify Telescoping PTO Shaft Length" in MAINTENANCE section.
- Ensure screens over auger are in place and properly secured.
- Transport chains are properly installed and hardware is torqued to specification. See "Transport Chain Connection" in OPERATION section.
- Paint all parts scratched in shipment.
- Test run the augers. See "Auger Operation" in OPERATION section.
- Check hydraulics for leaks and check hose routing.

## Set Up



Due to shipping requirements and various dealer-installed options, some initial cart set up will be required after it arrives from the factory. Use the following procedures as needed for initial cart set up.

### **WARNING**

- TO PREVENT PERSONAL INJURY OR DEATH WHILE SERVICING, ALWAYS ENSURE THAT THERE ARE PEOPLE WHO REMAIN OUTSIDE THE CART TO ASSIST THE PERSON WORKING INSIDE, AND THAT ALL SAFE WORKPLACE PRACTICES ARE FOLLOWED. THERE IS RESTRICTED MOBILITY AND LIMITED EXIT PATHS WHEN WORKING INSIDE THE IMPLEMENT.
- KEEP HANDS CLEAR OF PINCH POINT AREAS.
- FALLING OBJECTS CAN CAUSE SERIOUS INJURY OR DEATH. DO NOT WORK UNDER THE MACHINE AT ANY TIME WHILE BEING HOISTED. BE SURE ALL LIFTING DEVICES AND SUPPORTS ARE RATED FOR THE LOADS BEING HOISTED. THESE ASSEMBLY INSTRUCTIONS WILL REQUIRE SAFE LIFTING DEVICES UP TO 32,000 LBS. SPECIFIC LOAD RATINGS FOR INDIVIDUAL LOADS WILL BE GIVEN AT THE APPROPRIATE TIME IN THE INSTRUCTIONS.
- EYE PROTECTION AND OTHER APPROPRIATE PERSONAL PROTECTIVE EQUIPMENT MUST BE WORN WHILE SERVICING IMPLEMENT.

## SMV Emblem & SIS Decals

Before the cart is used, the reflective surface of the SMV must face rearward. This may require removal of film protecting the reflective surface or removing and reinstallation of the SMV. When reinstalling the SMV make sure that it is mounted with the wide part of the SMV at the bottom. (Fig. 2-2)

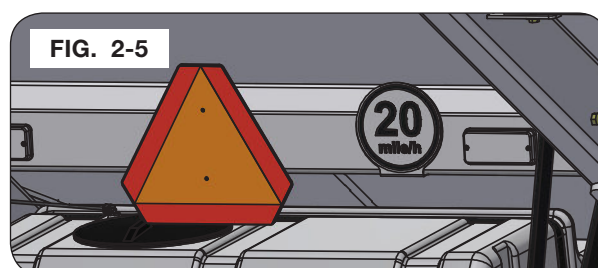
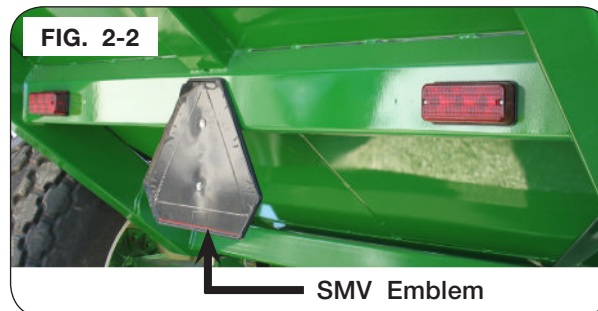
Before the cart is used, ensure the front and rear SIS placards are clean and visible after shipping. (Fig. 2-3)

Remove rear SIS decal mounting bracket from shipping position (Fig. 2-4) and reinstall as shown. (Fig. 2-5)

Before the cart is used, ensure the front and rear SIS decals are clean and visible.

For 20 M.P.H. SIS decals, order 9008715 for the front & 9008714 for the rear.

For 30 K.P.H. SIS decals, order 9008721 for the front & 9008720 for the rear.

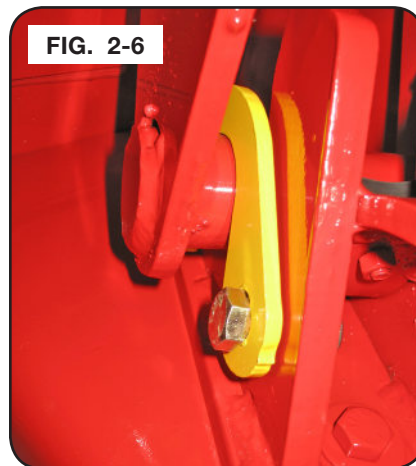


## Auger Rest Retainer Removal

Remove and discard the retainer located on the upper auger rest at the back of the cart, before folding out the upper auger tube, (Fig. 2-6 and 2-7)

### IMPORTANT

- *Upper auger retainer must be removed before operating upper auger tube. Failure to remove retainer will result in damage to the upper auger tube.*



## Jack & Optional Hydraulic Jack Set Up

### Jack

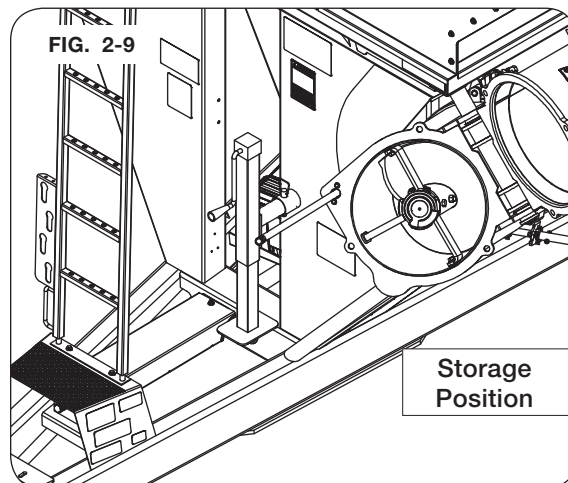
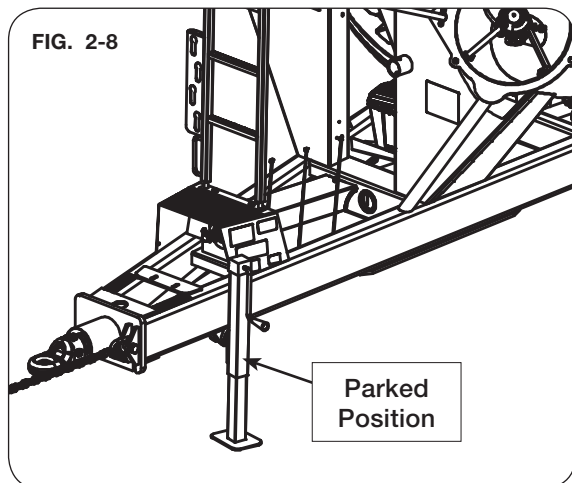
# WARNING

- UNHITCHING A LOADED CART CAN CAUSE SERIOUS INJURY OR DEATH DUE TO THE TONGUE RISING OR FALLING. ALWAYS HAVE A LOADED CART ATTACHED TO A TRACTOR. THE JACK IS INTENDED TO SUPPORT AN EMPTY CART ONLY.

Attach jack to left-outside frame using pin. Mount jack in storage position once cart is hitched to tractor. (Fig. 2-8 and 2-9)

## IMPORTANT

- Failure to store the jack in transport position could result in damage to the jack, cart, or tractor tire.

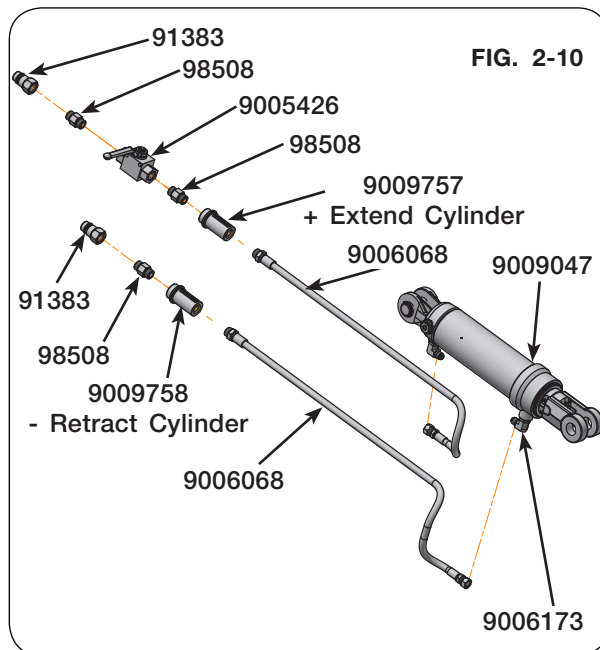


### Install Hydraulic Jack (Optional)

1. Park the unit on a firm, level surface. Block the machine to keep it from moving. Set the vehicle parking brake, shut off the engine and remove the ignition key and disconnect the PTO shaft from the tractor.



2. On new hydraulic assembly (294143B), assemble hoses (9006068) and fittings to cylinder (9009047) as shown in figure 2-10. The valve needs to be assembled to the hose on the base end of the cylinder. Assemble the fittings on the cylinder so they face each other, then store the hydraulic hoses on the hose caddy.



**Jack & Optional Hydraulic Jack Set Up** (continued)

**Install Hydraulic Jack (Optional)** (continued)

**⚠ WARNING**

- KEEP HANDS CLEAR OF PINCH POINT AREAS.

3. Assemble the cylinder (9009047) and jack foot (271723B) to the jack weldment (271712B) as shown in figure 2-11 using 1"-8UNC x 7" capscrews (9390-197) and 1"-8UNC locknuts (92199).

**NOTE:** Ensure all jack leg weldment (271712B) joints can pivot freely, including jack foot (271723B).

4. Tighten 1" hardware on jack leg weldment and allow the cylinder and jack foot to freely pivot. (Fig. 2-11)

5. Attach mounting bracket (273808B) to jack leg weldment (271712B) using 1"-8UNC x 7" capscrew (9390-197) and 1"-8UNC locknut (92199), before mounting to the tongue. (Fig. 2-12)

6. Tighten 1" hardware on jack leg weldment and allow the joint to pivot. (Fig. 2-12)

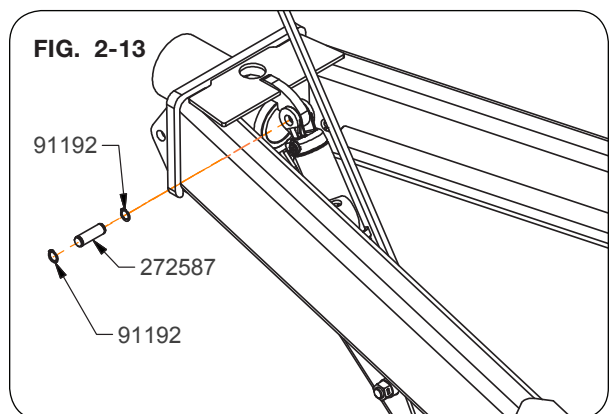
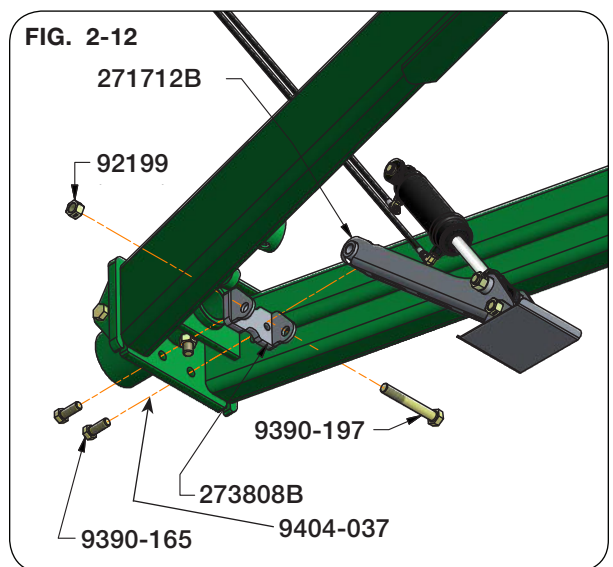
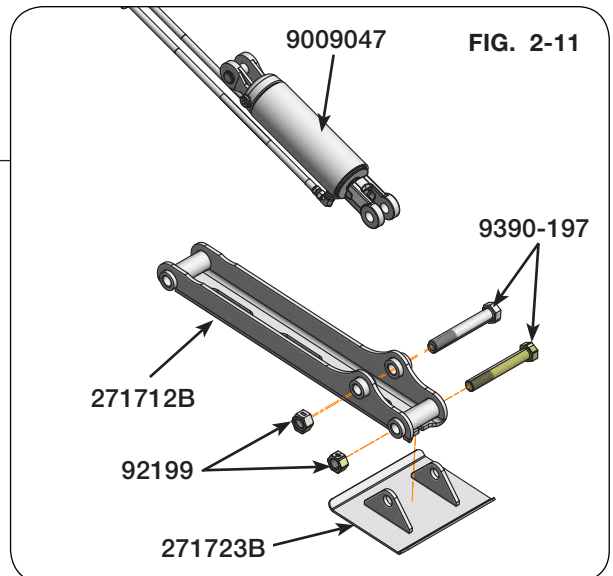
7. Attach the mounting bracket (273808B) to the back side of the front hitch plate with two 7/8"-9UNC x 2 1/4" capscrews (9390-165) and 7/8" lock washers (9404-037). (Fig. 2-12)

8. Torque 7/8" hardware to 330 ft.-lbs. (Fig. 2-12)

9. Align the base end of the cylinder with the lug on the top of the tongue and assemble the cylinder pin (272587) and snap rings (91192) shown in Fig. 2-13.

**NOTE:** Refer to "Optional Hydraulic Jack Usage" in the OPERATION section for additional information.

10. Purge air from system. See "Purge Hydraulic System" in the MAINTENANCE section for procedure.





## Lamp Set Up

Pivot lamp extension arms into position at sides of cart. The lamp bracket width is adjustable. Adjust lamp mount position to ensure that the reflectors are no more than 16" from the widest part of the tires, tracks, or grain cart body. Be sure that amber reflector is facing the front of the cart (some lights on certain cart models will be flipped down for shipping). See (Fig. 2-14 and 2-15)

Compliance with all lighting and marking laws is the responsibility of the operator at the time of travel.

See federal regulation 49 CFR 562; available at [www.govinfo.gov](http://www.govinfo.gov) for US federal law requirements.

See your Unverferth dealer for additional brackets, reflectors, or lights to meet your requirements.

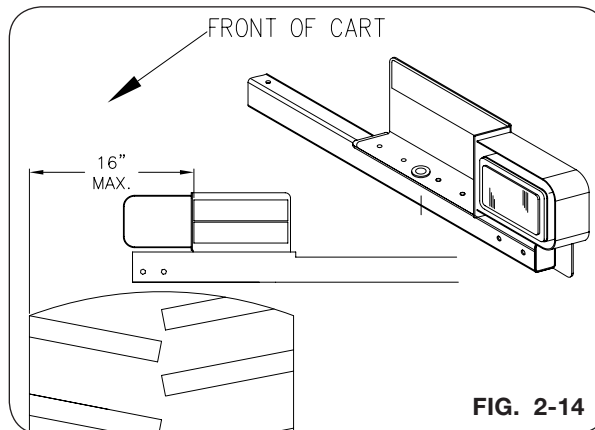


FIG. 2-14



FIG. 2-15

## Driveline

Using a safe lifting device rated at 100 lbs., remove PTO shaft from storage brackets located on the right-hand side of the frame. Attach to driveline. (Fig. 2-16)

### IMPORTANT

- Secure the complete PTO shaft to brackets for extended transport or storage and for all transport behind a delivery truck. Interference could occur when turning resulting in damage to PTO and cart.

**NOTE:** See "PTO Quick Disconnect - Coupling" in MAINTENANCE section for procedure.



FIG. 2-16

PTO Storage Located  
On The Right-Hand Side.



## **Wheel & Tire Set Up**

### **Tire Pressure**

Tire pressure must be verified before first use and adjusted as necessary. Refer to MAINTENANCE section of this manual for information on tire pressure.

### **Wheel Nuts**

#### **WARNING**

- **FALLING OBJECTS CAN CAUSE SERIOUS INJURY OR DEATH. DO NOT WORK UNDER THE MACHINE AT ANY TIME WHILE BEING HOISTED. BE SURE ALL LIFTING DEVICES AND SUPPORTS ARE RATED FOR THE LOADS BEING HOISTED. THESE ASSEMBLY INSTRUCTIONS WILL REQUIRE SAFE LIFTING DEVICES UP TO 32,000 LBS. SPECIFIC LOAD RATINGS FOR INDIVIDUAL LOADS WILL BE GIVEN AT THE APPROPRIATE TIME IN THE INSTRUCTIONS.**

---

- **KEEP HANDS CLEAR OF PINCH POINT AREAS.**

---

- **EYE PROTECTION AND OTHER APPROPRIATE PERSONAL PROTECTIVE EQUIPMENT MUST BE WORN WHILE SERVICING IMPLEMENT.**

---

- **TIPPING OR MOVEMENT OF THE MACHINE CAN CAUSE SERIOUS INJURY OR DEATH. BE SURE MACHINE IS SECURELY BLOCKED.**

#### **CAUTION**

- **IMPROPERLY TORQUED WHEEL NUTS/BOLTS CAN CAUSE A LOSS OF IMPLEMENT CONTROL AND MACHINE DAMAGE. WHEEL NUTS/BOLTS MUST BE CHECKED REGULARLY. SEE TORQUE PAGE IN THE MAINTENANCE SECTION FOR PROPER WHEEL NUT/BOLT SPECIFICATIONS. WARRANTY DOES NOT COVER FAILURES CAUSED BY IMPROPERLY TORQUED WHEEL NUTS/BOLTS.**

#### **IMPORTANT**

- *Installing wheels without the proper inset/offset could result in hub or spindle failure. This will cause substantial damage to cart and is not covered by warranty. Inset/offset will vary depending on tire size. Consult dealer for proper inset/offset.*

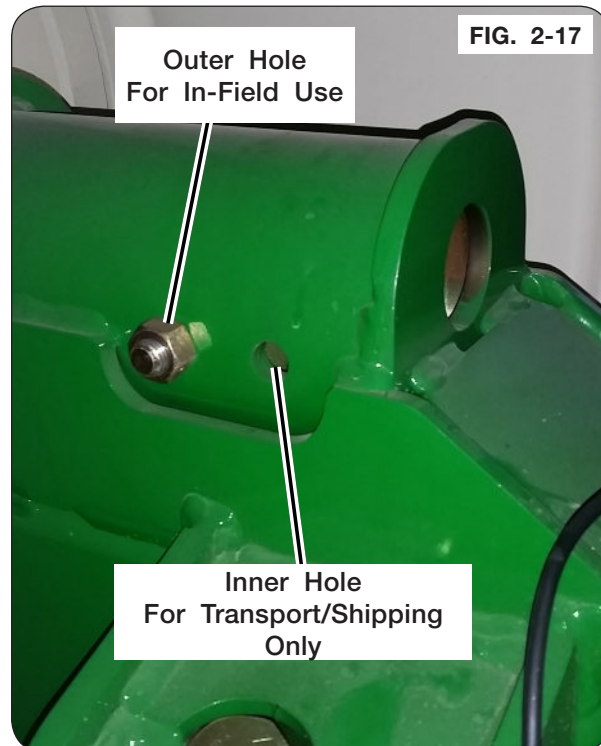
## Spindle Positioning

### IMPORTANT

- *Single tire hubs and spindles are slid in for shipping and need to be slid out before attaching wheels/tires to provide adequate clearance between tires and wheel wells.*

Spindles on carts with single wheels are moved inward for transportation. To achieve proper tire clearance during field operation, these spindles must be moved outward prior to cart use. (Fig. 2-17)

1. Hitch cart to tractor. Park the empty cart on a firm, level surface. Set tractor parking brake, shut off engine, and remove ignition key. Block the machine to prevent movement.
2. Use safe lifting and load holding devices rated at 32,000 lbs. to lift and support the weight of the grain cart. Place the safe lifting device under the axle closest to the tire
3. Remove 3/4" X 8" spindle retainer capscrew and locknut.
4. Using a safe lifting device rated at a minimum 600 lbs, slide spindle out.
5. Reinstall capscrew and locknut. Torque to specification.
6. Remove safe lifting device (or support) and repeat for other side.



## Sideboards and End Caps Installation

1. Park the empty grain cart on a firm, level surface. Block the machine to keep it from moving. Set the tractor's parking brake, shut-off the engine, remove the ignition key and disconnect the PTO shaft.
2. Remove the crank handle, crank handle holder, shipping bundle which includes front and rear end caps, and small front and rear sideboards from inside the cart.
3. Remove and discard shipping hardware from right-hand sideboards. (Fig. 2-18)
4. Lift the right-hand sideboards into position and loosely secure sideboard into place using 3/8"-16UNC x 3/4" flange screws (95585) and 3/8"-16UNC flange nuts (91263) along sideboard bottom edge. (Fig. 2-19)

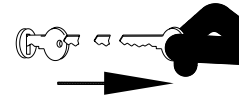
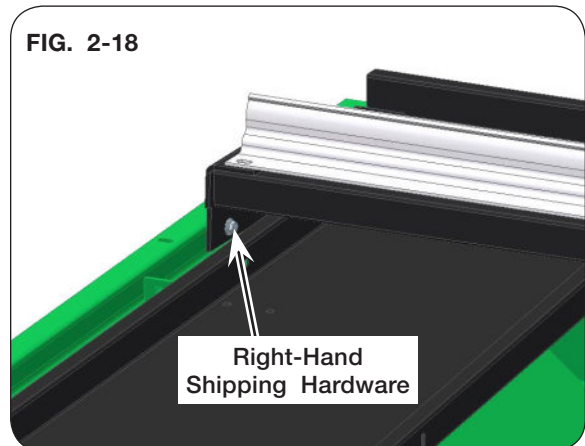


FIG. 2-18



**NOTE:** Hinge brackets WILL support the sideboard. (Fig. 2-19 and 2-20)

**NOTE:** The right-hand sideboard bracket weldments (295681B) come from the factory attached between the right-hand sideboards. (Fig. 2-20)

5. Loosely secure sideboard cover plate (295691B) with 3/8"-16UNC x 1" carriage bolts (9388-051) and 3/8"-16UNC flange nuts (91263) to the inside bottom right-hand front and rear sideboards. (Fig. 2-20)



FIG. 2-19

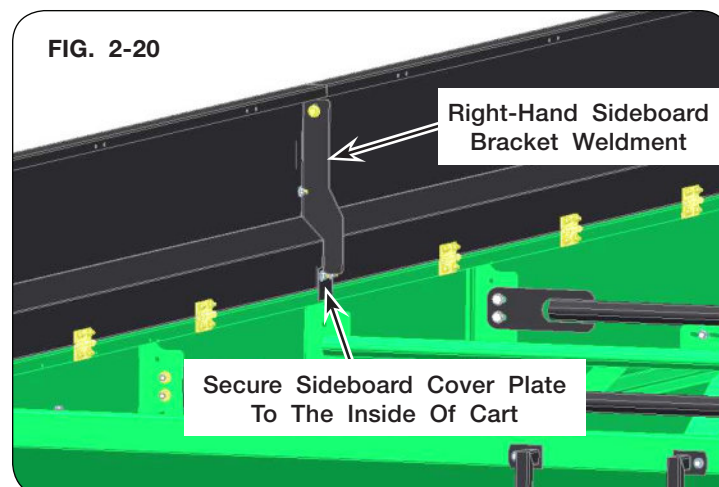
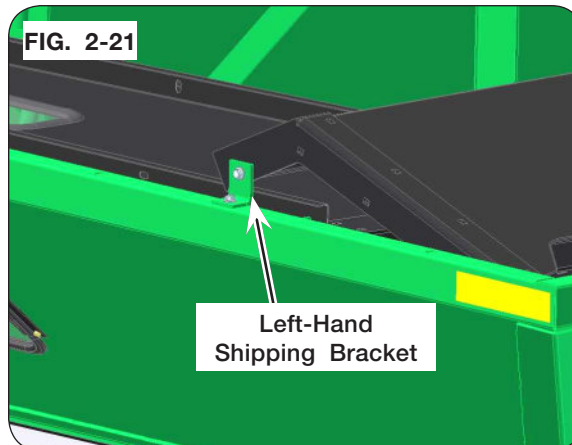


FIG. 2-20

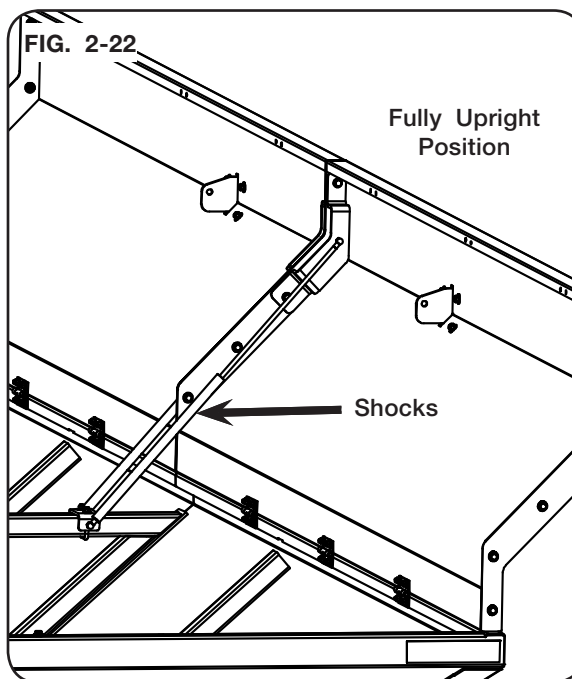
**Sideboards and End Caps Installation** (continued)

6. Remove and discard shipping bracket for left-hand sideboard. (Fig. 2-21)
7. Lift the left-hand sideboards into position.

**NOTE:** Hinge brackets WILL support the sideboard and tarp.



**NOTE:** Shocks are attached to the left-hand sideboard. (Fig. 2-22)



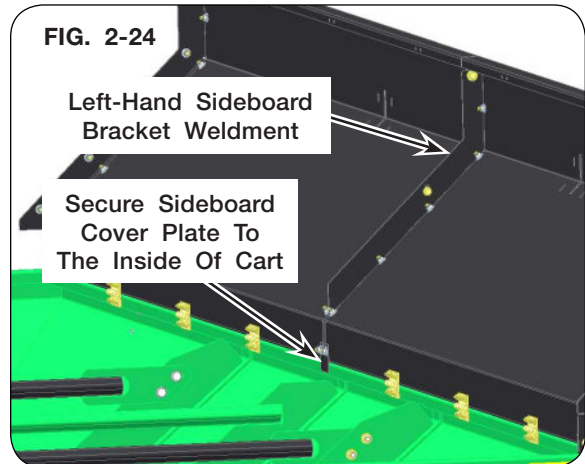
8. Loosely secure left-hand sideboard with 3/8"-16UNC x 3/4" flange screws (95585) and 3/8"-16UNC flange nuts (91263) along the bottom edge. (Fig. 2-23)



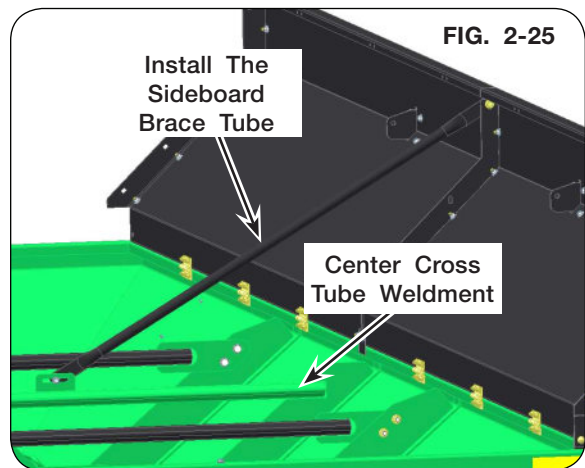
**Sideboards and End Caps Installation (continued)**

**NOTE:** The left-hand sideboard bracket weldments (295682B - V1300; 296385B - V1500) come from the factory attached between the left-hand sideboards (Fig. 2-24)

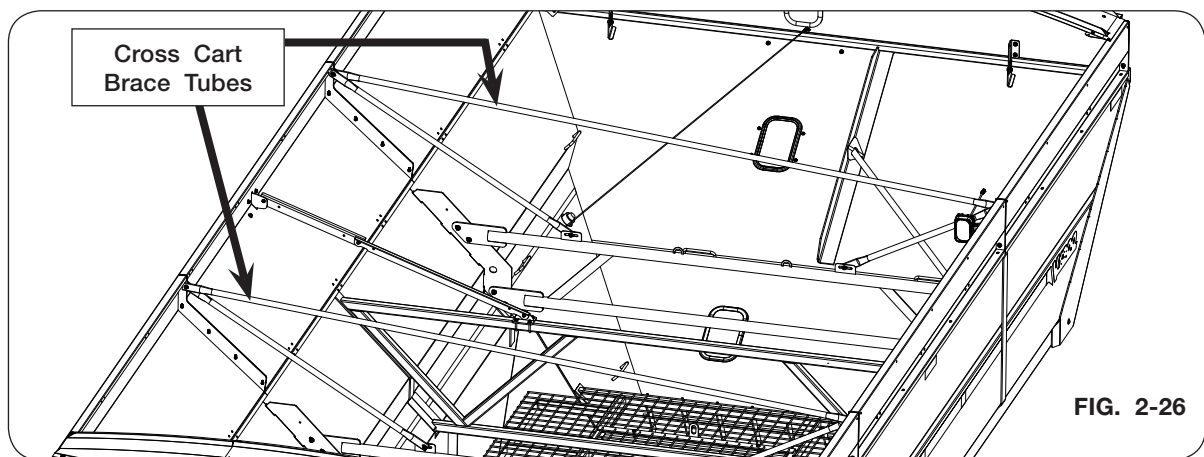
9. Loosely secure sideboard cover plate (295691B) with 3/8"-16UNC x 1" carriage bolts (9388-051) and 3/8"-16UNC flange nuts (91263) to the inside bottom left-hand front and rear sideboards. (Fig. 2-24)



10. ONE PIECE BRACE TUBE:  
Install two sideboard brace tubes (287692B - V1300; 288653B - V1500) to the left-hand sideboards and center cross tube weldments, and two sideboard brace tubes (220032B) to right-hand sideboards and center cross tube weldments. Loosely secure with 3/8"-16UNC x 1 1/2" flange screws (95785) and 3/8"-16UNC flange nuts (91263). (Fig. 2-25)



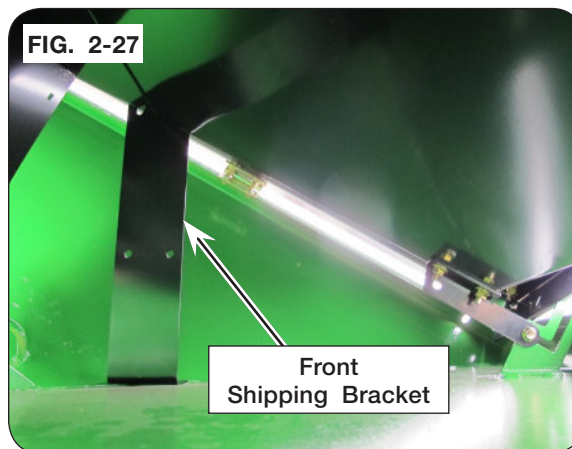
11. CROSS CART BRACE TUBES:  
Install cross-cart, full-width brace tubes (288377B - V1300; 288641B - V1500). Loosely affix to sideboard brace tubes using 3/8" flange hardware. See figure 2-26.



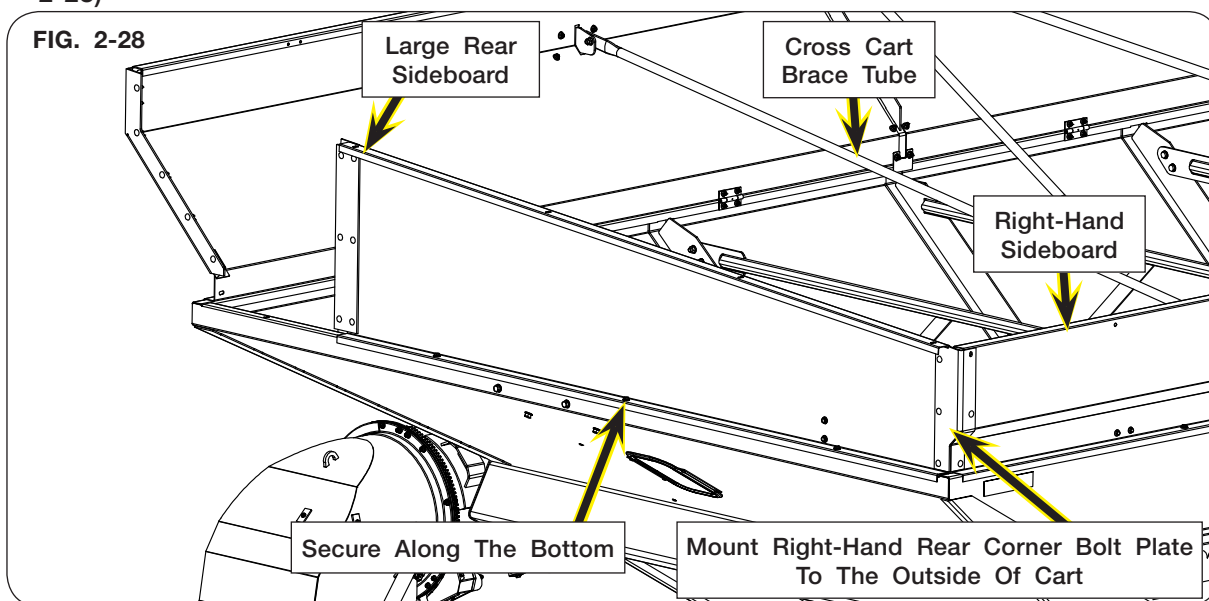


**Sideboards and End Caps Installation** (continued)

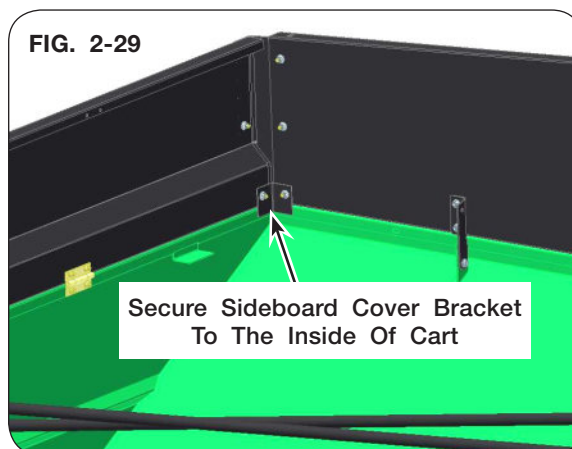
- 12. Remove and discard the shocks and associated brackets from the left-hand sideboard.
- 13. Remove and discard the shipping brackets from the rear and front sideboards. Front sideboard shown in figure 2-27.



- 14. Lift the large rear sideboard (295671B) up into position and loosely secure with flange screws (95585) and flange nuts (91263) along the bottom. (Fig. 2-28)
- 15. Connect large rear sideboard to right-hand sideboard using right-hand rear corner sideboard bolt plate (295680B). Loosely secure using (9388-051) and (91263) hardware. (Fig. 2-28)

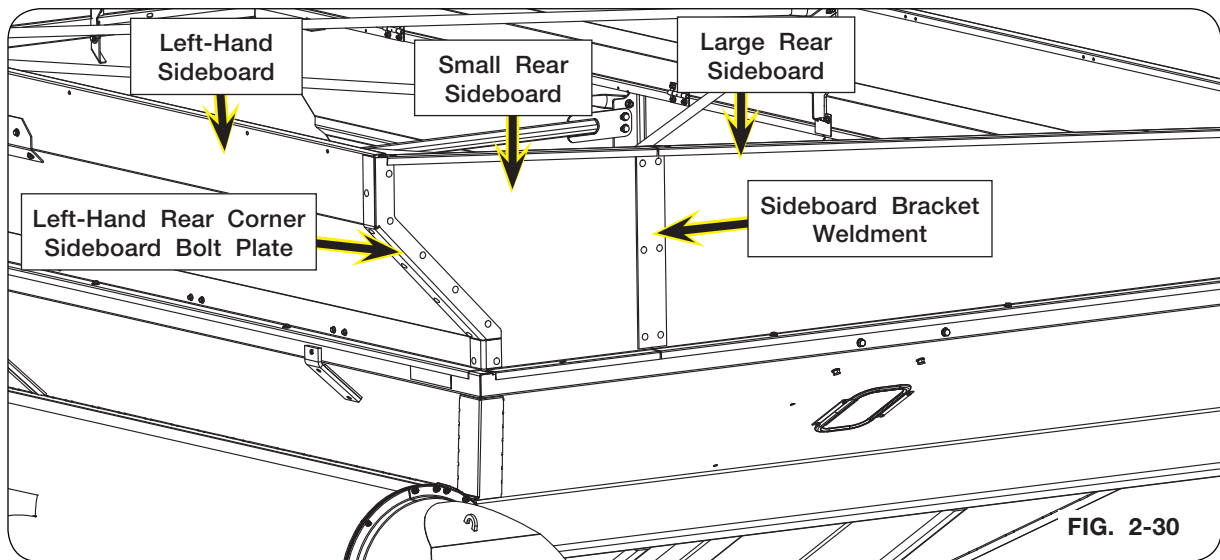


- 16. Loosely secure sideboard cover bracket (295667B) with (9388-051) and (91263) hardware to the inside right-hand bottom corner of large rear sideboard and the right-hand sideboard. (Fig. 2-29)



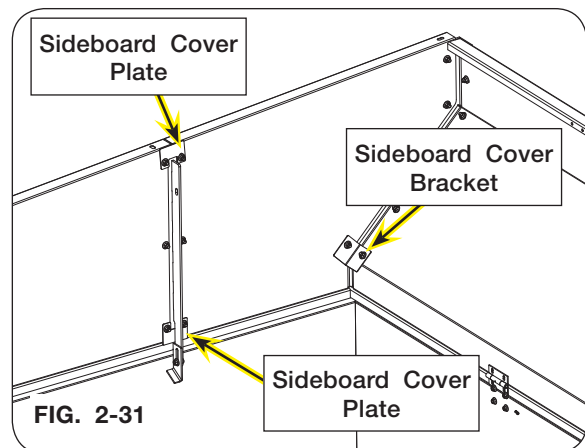
**Sideboards and End Caps Installation** (continued)

17. Loosely connect the small rear sideboard to the large rear sideboard using the sideboard bracket weldment (295697B) and (9388-051) and (91263) hardware. Also, loosely install flange screws (95585) and flange nuts (91263) along the bottom. (Fig. 2-30)
18. Loosely attach small rear sideboard to the left-hand sideboard using the left-hand rear sideboard corner bolt plate (295678B - V1300; 296381B - V1500) on the outside of the sideboards with (9388-051) and (91263) hardware. (Fig. 2-30)



**FIG. 2-30**

19. Loosely secure sideboard cover plate (295667B) with (9388-051) and (91263) hardware to the inside left-hand bottom corner of small rear sideboard. (Fig. 2-31)
20. Loosely affix sideboard cover plate (295691B) with (9388-051) and (91263) hardware to the inside top and bottom rear sideboards and the rear sideboard bracket weldment. (Fig. 2-31)



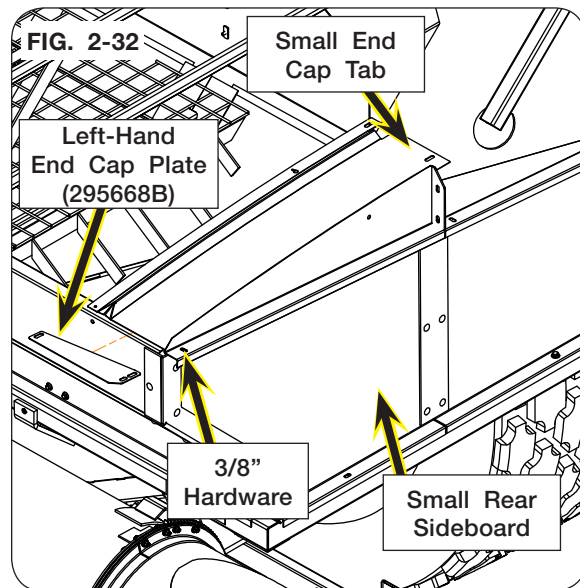
**FIG. 2-31**

**Sideboards and End Caps Installation (continued)**

21. Attach small rear end cap (288343B - V1300; 288647B - V1500) on top of rear sideboard. Loosely secure using flange screws (95585) and flange nuts (91263) hardware along the bottom. (Fig. 2-32)

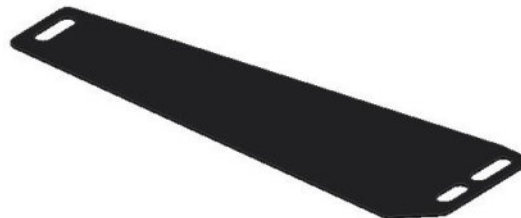
**NOTE:** The small end cap tab will fit underneath the large end cap. (Fig. 2-32)

22. Install left-hand end cap plate (295668B) between the end cap, small rear sideboard, and left-hand sideboard. (Fig. 2-32 and 2-33)



**FIG. 2-33**

**Left-Hand End Cap Plate (295668B)**



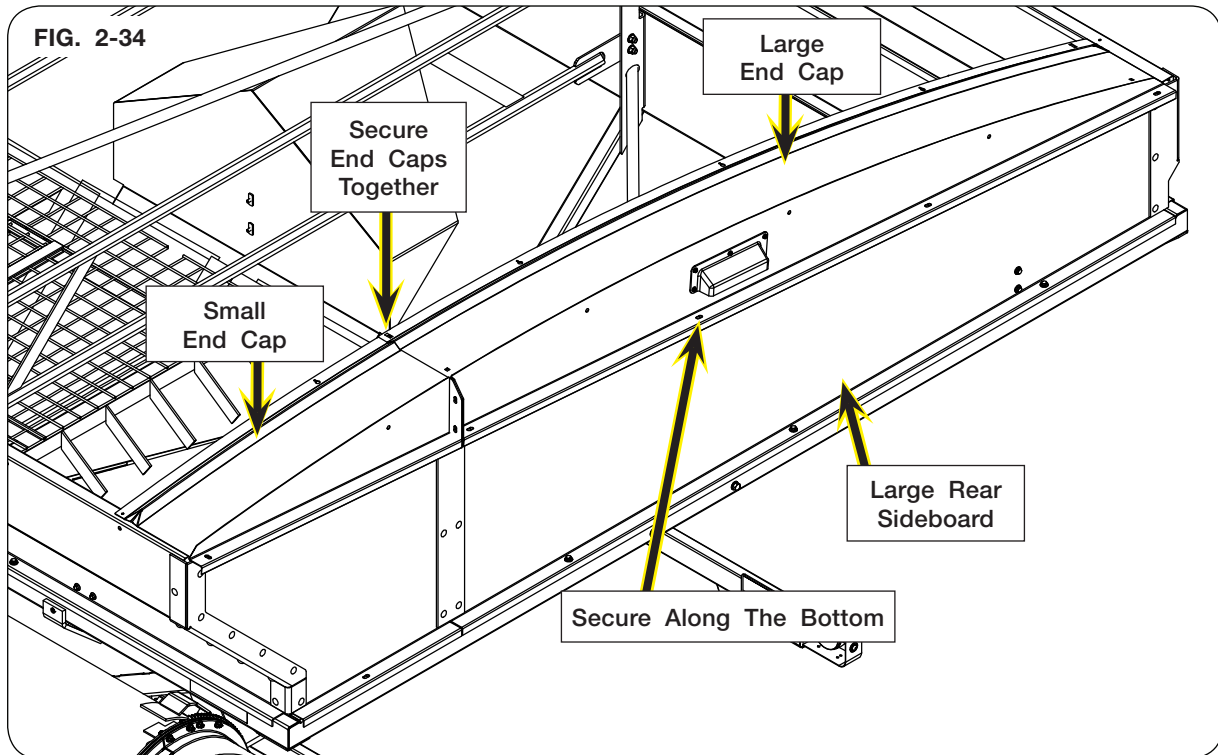


**Sideboards and End Caps Installation** (continued)

23. Attach large rear end cap (296131B - V1300; 296143B - V1500) on top of rear sideboard using flange screws (95585) and flange nuts (91263) along the bottom. (Fig. 2-34)

**NOTE:** Tabs on smaller end cap go UNDER the larger end cap.

24. Loosely secure large rear end cap to small rear end cap using two 3/8"-16 x 1" truss head screws (9005312) and two 3/8"-16 flange nuts (91263). (Fig. 2-34)

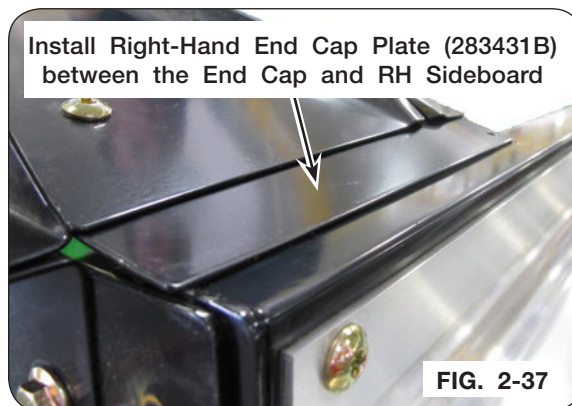
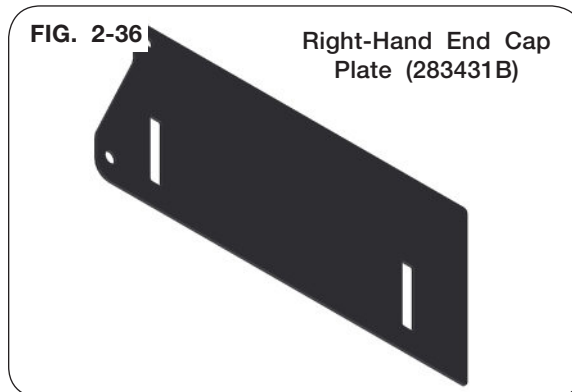
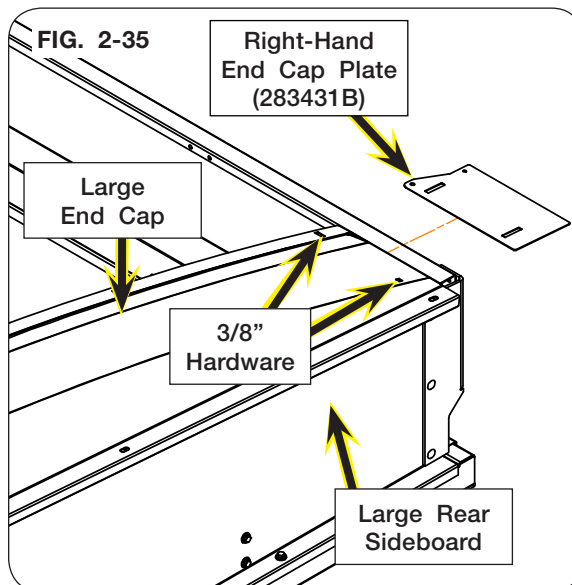


**Sideboards and End Caps Installation** (continued)

25. Position right-hand end cap plate (283431B) between the end cap and right-hand sideboard. (Fig. 2-35 through 2-37)

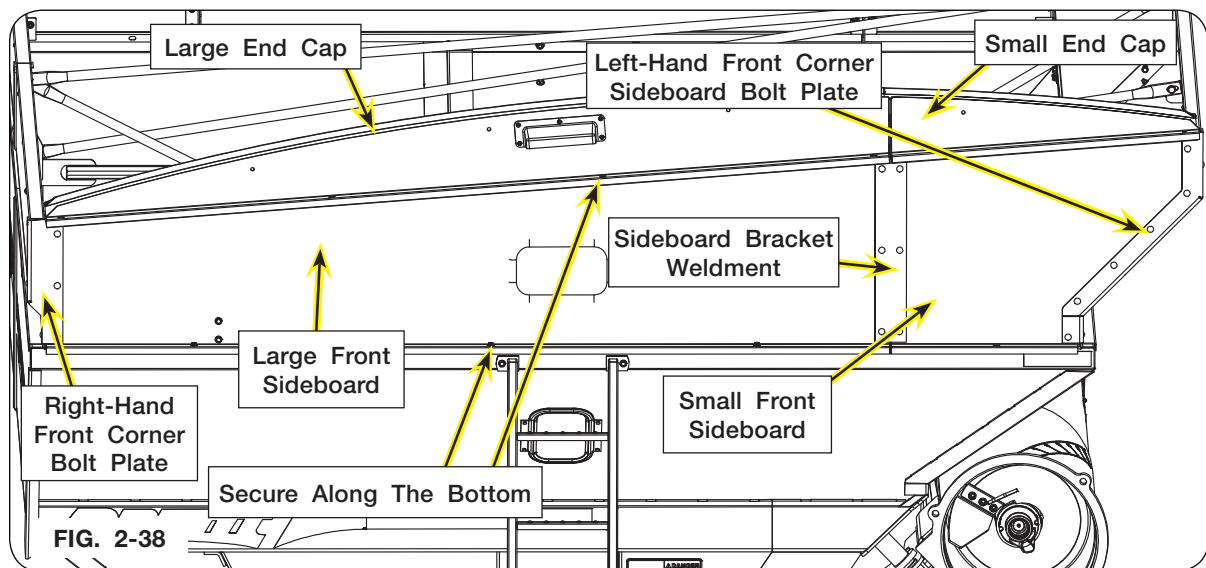
26. Loosely retain by using two truss head screws (9005312) and two flange nuts (91263). (Fig. 2-35 through 2-37)

**NOTE:** Right-hand end cap plates must be installed at least 1/4" from the outside edge of the sideboard to prevent tearing the tarp.



**Sideboards and End Caps Installation** (continued)

27. Lift large front sideboard (297652B - V1300; 297653B - V1500) into position. (Fig. 2-38)



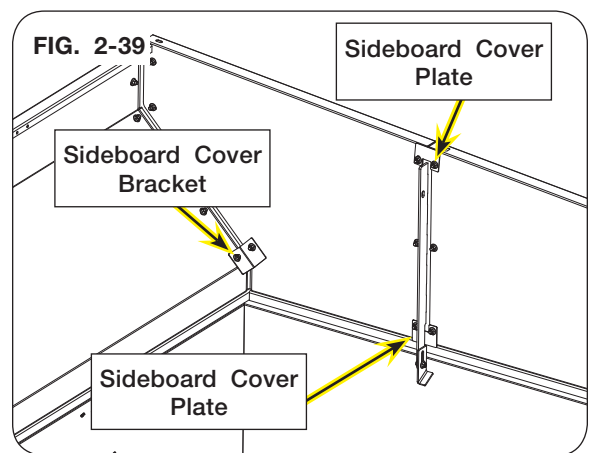
28. Connect large front sideboard to the right-hand sideboard using the right-hand front corner sideboard bolt plate (295679B). Loosely secure using (9388-051) and (91263) hardware. (Fig. 2-38)

29. Loosely connect the small front sideboard (295670B - V1300; 296373B - V1500) to large front sideboard using the sideboard bracket weldment (295697B) and (9388-051) and (91263) hardware.

30. Loosely install flange screws (95585) and flange nuts (91263) along the bottom perimeter. (Fig. 2-38)

31. Loosely attach small front sideboard to the left-hand sideboard using the left-hand front corner sideboard bolt plate (295677B - V1300; 296380B - V1500) on the outside of the sideboards with (9388-051) and (91263) hardware. (Fig. 2-38)

32. Loosely secure sideboard cover bracket (295667B) and plates (295691B) with (9388-051) and (91263) to the inside left-hand bottom sideboard corners and front sideboards. (Fig. 2-39)

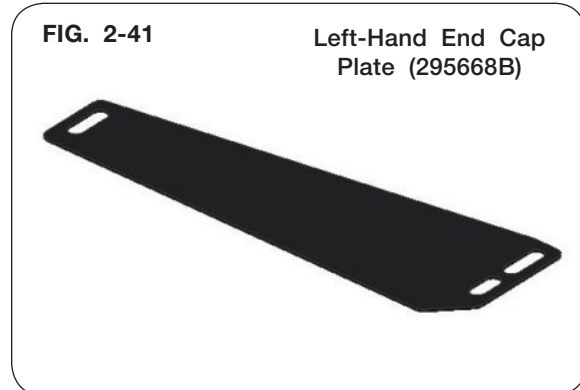
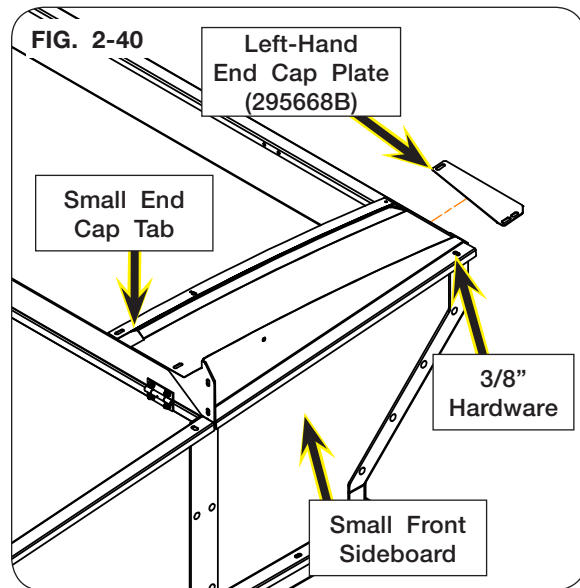


**Sideboards and End Caps Installation** (continued)

33. Attach small front end cap (288341B - V1300; 288646B - V1500) on top of front sideboards. Loosely secure using flange screws (95585) and flange nuts (91263) hardware along the bottom. (Fig. 2-40)

**NOTE:** The small end cap tab will fit underneath the large end cap. (Fig. 2-40)

34. Install left-hand end cap plate (295668B) between the end cap, small rear sideboard, and left-hand sideboard. (Fig. 2-40 and 2-41)

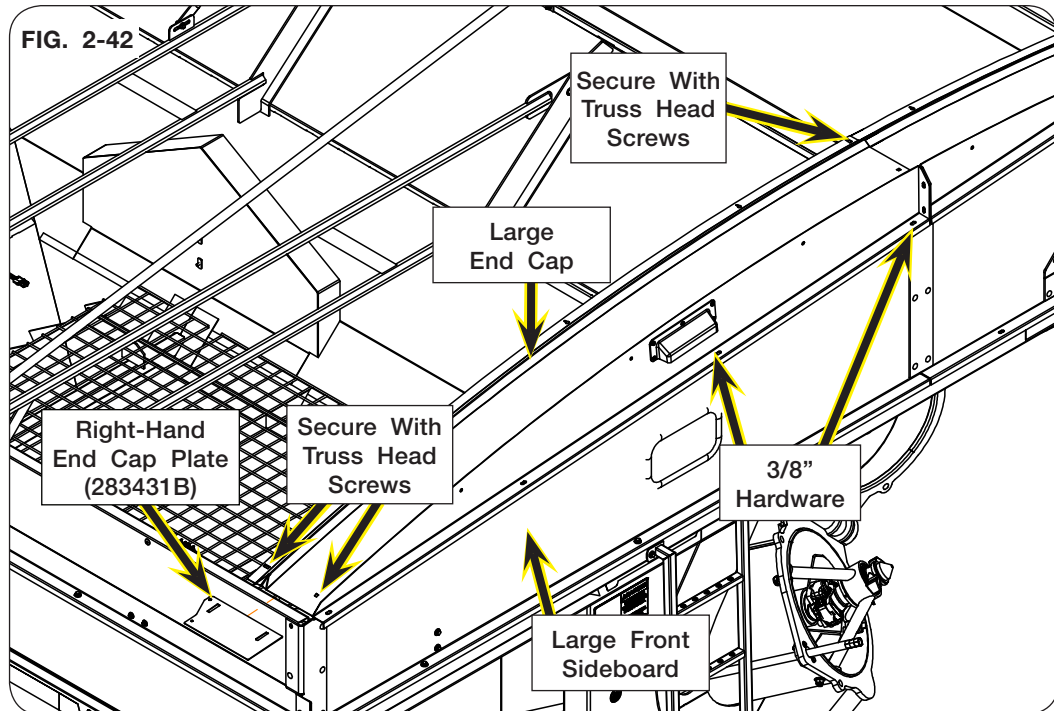


### Sideboards and End Caps Installation (continued)

35. Attach large front end cap (296129B - V1300; 296142B - V1500) on top of front sideboards using flange screws (95585) and flange nuts (91263) hardware along the bottom. (Fig. 2-42)

**NOTE:** Large front end cap goes over the tabs on the small end cap previously installed.

36. Loosely secure large front end cap to small front end cap using truss head screws (9005312) and flange nuts (91263). (Fig. 2-42)



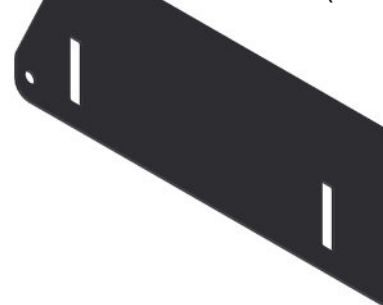
37. Install right-hand end cap plate (283431B) between the end cap and right-hand sideboard. (Fig. 2-42 and 2-43)

**NOTE:** Right-hand end cap plates must be installed at least 1/4" from the outside edge of the sideboard to prevent tearing the tarp.

38. Loosely fasten end cap plate by using truss head screws (9005312) and flange nuts (91263). (Fig. 2-42 and 2-43)

**NOTE:** DO NOT tighten hardware at this time. Wait until tarp bows are in place before torquing hardware.

FIG. 2-43 Right-Hand End Cap Plate (283431B)



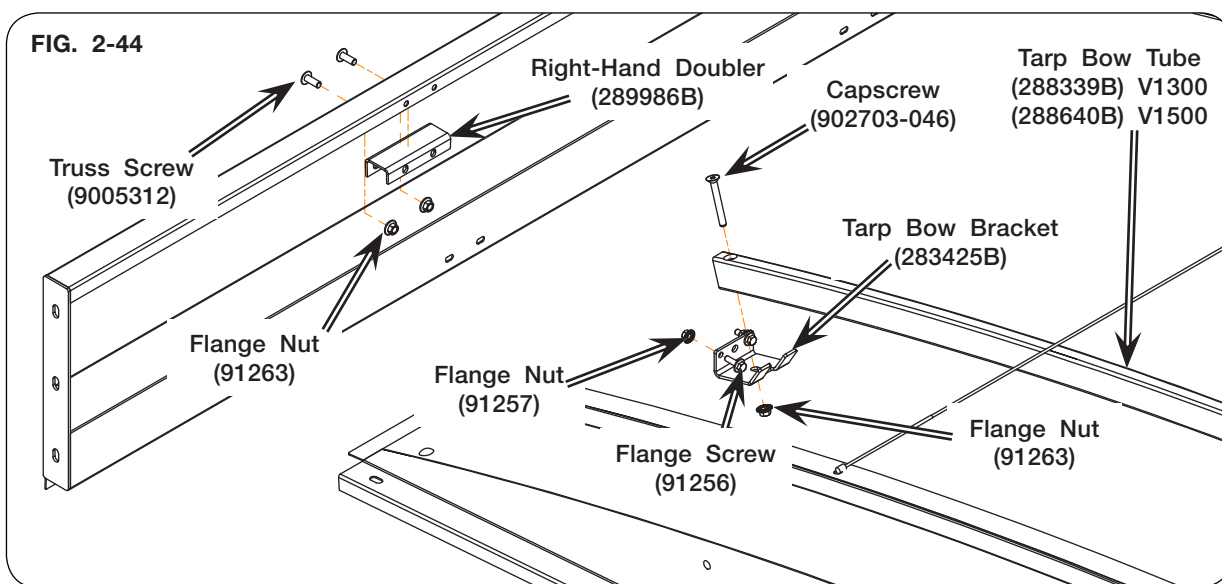
## Tarp Installation

**NOTE:** Ensure RH and LH doublers are inside the sideboard lip. (Fig. 2-44)

**NOTE:** For each of the eight tarp bows, complete the following steps:

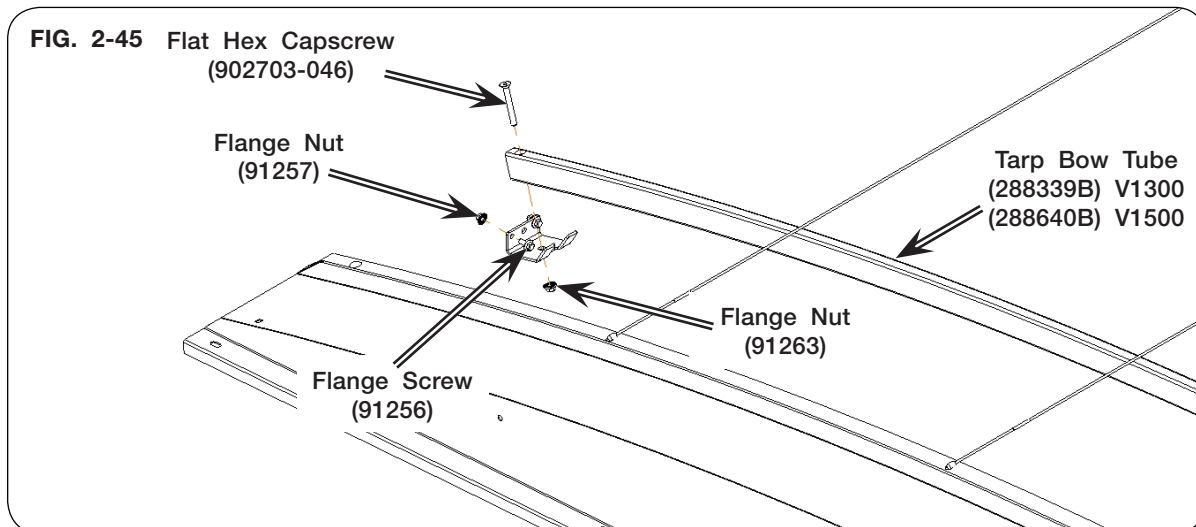
1. Attach a doubler (right-hand 289986B, left-hand (281936B) under the sideboard lip and secure with truss screws (9005312) and flange nuts (91263).
2. Attach right-hand and left-hand tarp bow brackets (283425B and 283427B) with flange screws (91256) and flange nuts (91257).

**NOTE:** Right-hand sideboard may need to be pulled inwards to align holes and attach tarp bows.



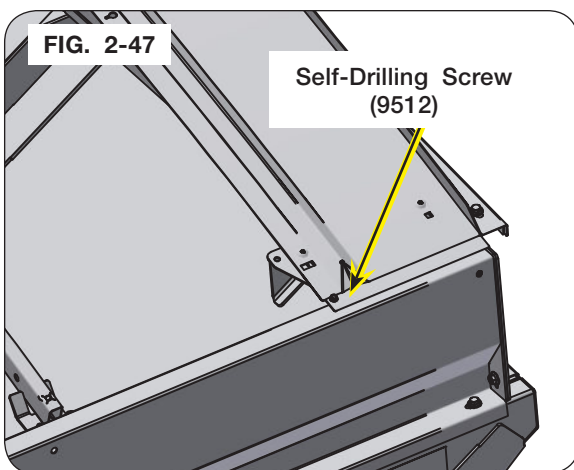
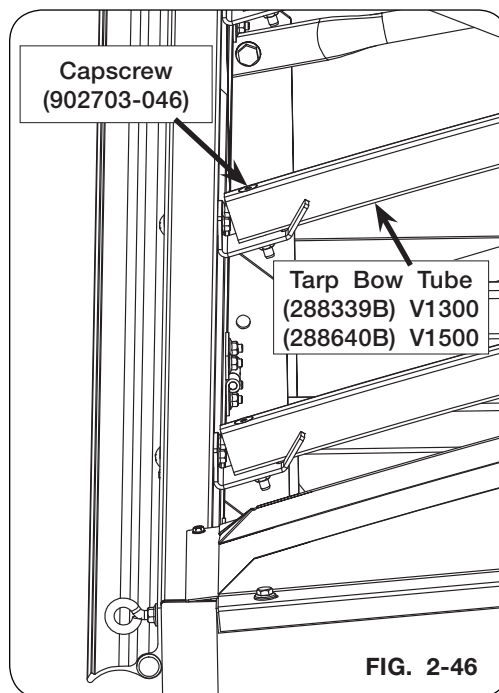
**Tarp Installation (continued)**

3. Install eight long tarp bows (288339B for V1300; 288640B for V1500) across the top of the cart using 3/8"-16UNC x 3" flat hex capscrew (902703-046), 3/8"-16UNC (91263) flange nut, 5/16"-18UNC x 3/4" flange screw (91256) and 5/16"-18UNC flange nut (91257). (Fig. 2-45)



**NOTE:** Ensure capscrew head (902703-046) is flush with the top of tarp bow tube. (Fig. 2-46)

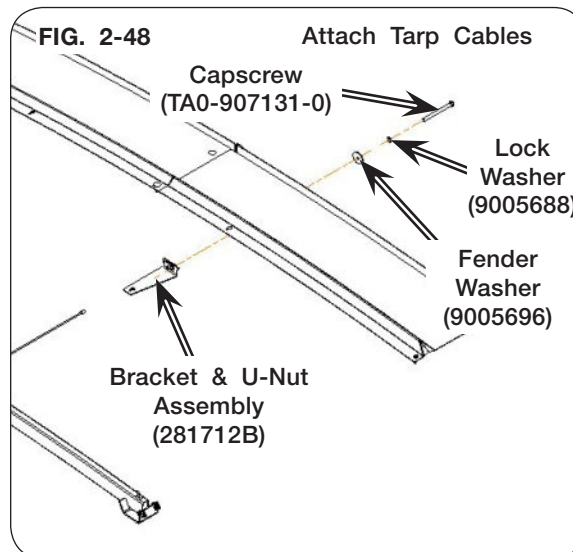
4. Tighten ALL hardware.  
Torque 3/8" hardware to 25–28 ft.-lbs.
5. Retain right-hand end cap plates to right-hand sideboards by using one 1/4"-14 x 1" self-drilling screw (9512) for the front and rear of the cart. (Fig. 2-47)
6. Retain small end caps, left-hand end cap plates, and left-hand sideboards by using one 1/4"-14 x 1" self-drilling screw (9512) for the front and rear of the cart. (Fig. 2-47)



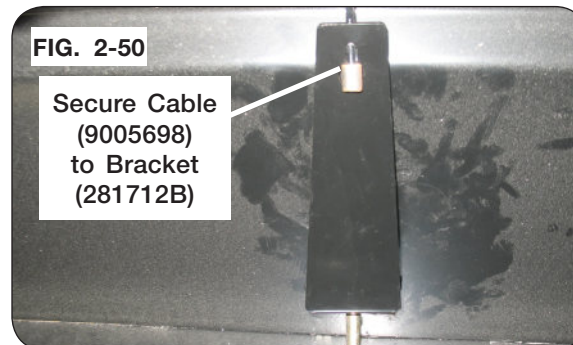
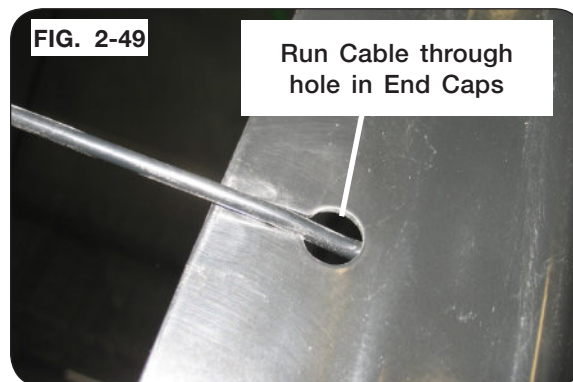


**Tarp Installation** (continued)

7. Install four bracket & U-nut assemblies (281712B) using 3/8"-16UNC x 4 1/2" capscrews (TA0-907131-0), 3/8" lock washers (9005688), and 3/8" fender washers (9005696). (Fig. 2-48)



8. Insert nylon coated cable, through hole in front end cap and route over tarp bows. Insert through hole in rear end cap and secure to keyhole slot in adjusting bracket under end cap. (Figs. 2-49 through 2-51)
9. Tighten cables until snug, without pulling front and rear board inward. Do not over-tighten.

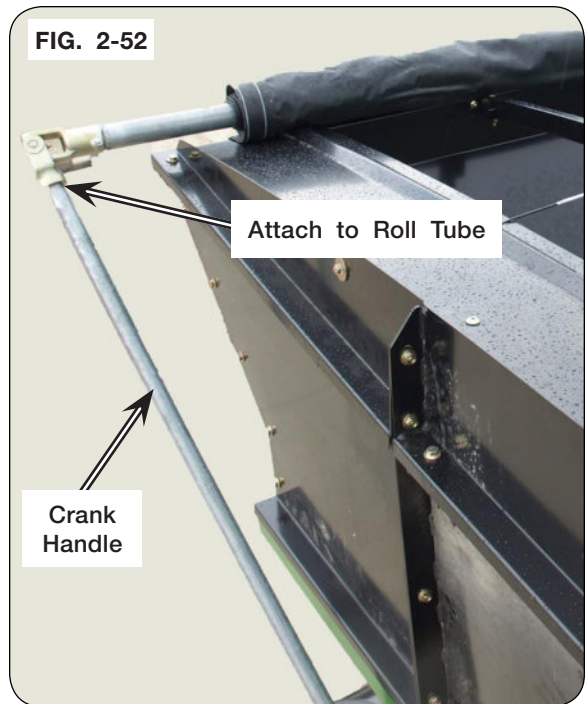




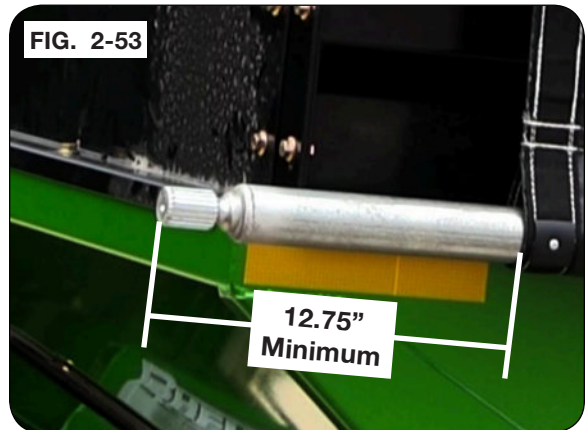
### Tarp Installation (continued)

10. Attach the crank handle (287944) to the tarp roll tube (288360) and secure with roll pin (9092-180). Roll tarp across the cart to the closed position. (Fig. 2-52)

**NOTE:** Remove zip ties holding tarp roll. Take care not to damage tarp.



11. Remove crank handle from roll tube.
12. Confirm that the roll tube protrudes at a minimum of 12.75" from the edge of tarp. Adjust roll tube if needed. (Fig. 2-53)

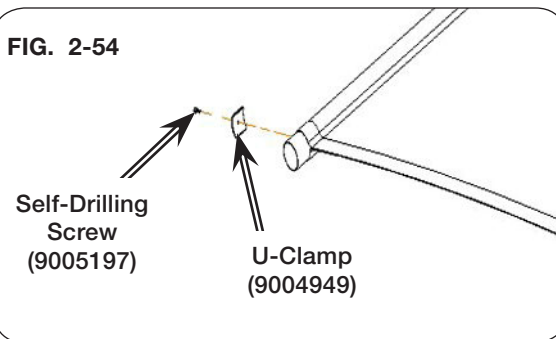


**Tarp Installation (continued)**

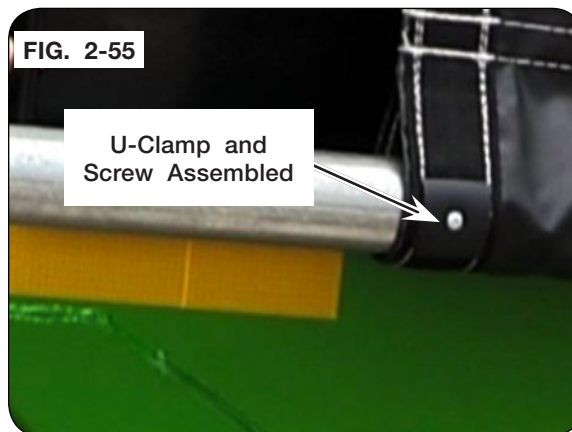
13. Beginning at the front of the cart, use #10-16 x 3/4" self-drilling screws (9005197) and U-clamps (9004949) to secure tarp in place on the roll tube. Check that clips are located on the straps with an even height across. (Fig. 2-54 and 2-55)

14. If not already affixed, attach the crank handle holder (256712B) to the brackets underneath on the rear of the cart using capscrews (9390-099) and flange nuts (9002058).

**FIG. 2-54**

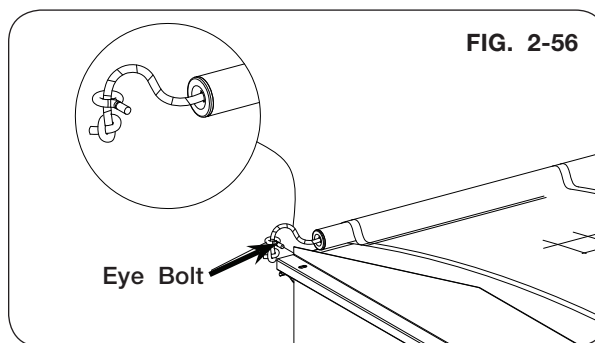


**FIG. 2-55**



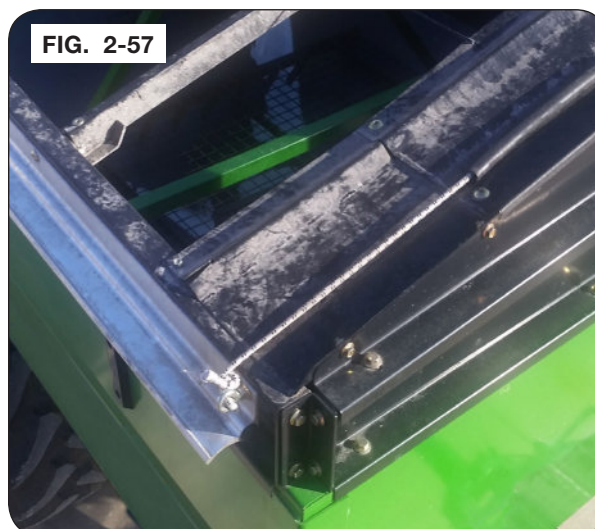
15. Turn the crank handle clockwise with tarp rolled up under latch plates (296847 - front and rear; 296848 - middle), thread the bungee cord end through the top of the eye bolt. Leave 2-3 inches of slack and knot off. Cut off excess 2-3 inches past knot. Sear end to keep from fraying, (Fig. 2-58).

**FIG. 2-56**



16. Test tarp for proper working motion. (Fig. 2-57)

**FIG. 2-57**



## Operational Check

### **WARNING**

- **MOVING OR ROTATING COMPONENTS CAN CAUSE SERIOUS INJURY OR DEATH. ENSURE SERVICE COVERS, CHAIN/BELT COVERS AND CLEAN-OUT DOOR ARE IN PLACE AND SECURELY FASTENED BEFORE OPERATING UNIT.**

### **IMPORTANT**

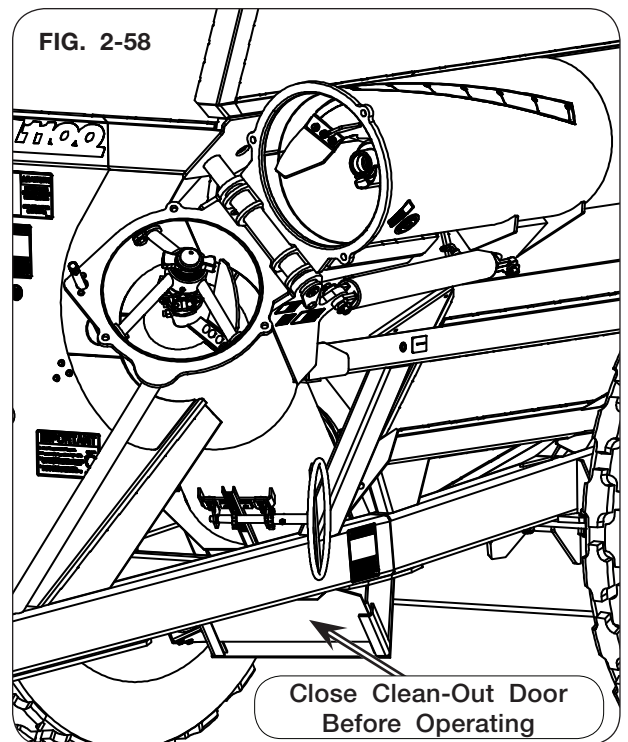
- *Before running the auger, inspect and verify all grain dust and filings are removed from inside the lower auger to prevent machine damage and the cleanout door is completely closed.*

**NOTE:** For cleanout door assembly adjustment, refer to “Adjusting Cleanout Door” in the MAINTENANCE section.

**NOTE:** The joystick and 7-pin connector **MUST** be plugged into the same power source. If plugged into different power sources, the spout rotate and auger fold functions **WILL NOT** operate normally.

Once set-up has been completed, run the cart to check for operation and functionality:

1. Lights - Work, Turn, Brake
2. Hydraulic Drive (if applicable)
3. Flow Door
4. Flow Door Indicator
5. Open & Close Cleanout Door
6. Auger Fold
7. Spout Rotate (if applicable)
8. Spout Tilt
9. Auger Startup & Shut-down
10. Tarp
11. Video System Camera (if applicable)
12. Scale (if applicable)



**Notes**

## **Section III Operation**

Operating Checklist.....	3-2
Preparing Tractor.....	3-2
Preparing Cart.....	3-3
Hardware .....	3-3
Pivot Pins .....	3-3
Hitch .....	3-3
Auger .....	3-3
Auger Driveline Assembly.....	3-4
Soft Start System.....	3-4
Hydraulic System.....	3-4
Tires/Wheels.....	3-4
Lubrication.....	3-4
Hitching to Tractor .....	3-5
Drawbar Connection .....	3-5
Jack Usage.....	3-6
Optional Hydraulic Jack Usage .....	3-7
Transport Chain Connection.....	3-8
Hydraulic Connections for Hydraulic Drive.....	3-9
Hydraulic Connections .....	3-9
Hydraulic Connections for Optional Water Delivery System .....	3-10
Electrical Connections.....	3-11
Electric Over Hydraulic Operation - 4 Function (Optional) .....	3-12
Cart Loading Sequence.....	3-15
Towing.....	3-16
Auger Operation.....	3-17
Rear Ladder Operation.....	3-19
Rear Access Door Operation.....	3-21
Weather Guard Tarp.....	3-22
Electric Tarp Wireless Receiver and Control Box Location .....	3-24

FOR SCALE, TRACK, UHARVEST, HYDRAULIC DRIVE, ELECTRIC TARP, AND / OR WATER DELIVERY SYSTEM INFORMATION, PLEASE REFER TO THE INDIVIDUAL MANUALS.

## **Operating Checklist**

- Read and understand all safety precautions before operating cart.
- R.V. antifreeze needs to be completely flushed from the Water Delivery System and disposed of properly. Make certain the Water Delivery System only contains water before placing the Water Delivery System in service. (If applicable)
- Test operation and functionality of flow door stop valve (9002151).
- Test operation and functionality of flow door indicator, auger fold, spout rotate, spout tilt, tarp, rear access door and if equipped, hydraulic jack stand, scale, joystick, scale remote display, video system, and water delivery system.
- Verify transport lights are working properly. Check and follow all regulations before towing on a road or highway.
- Verify tractor drawbar height and length. See “Preparing Tractor” in this section.
- Verify hitch height and length as outlined in OPERATION section.
- Ensure cleanout door and rear access door are closed and latched.
- Ensure rear ladder is in storage position.
- Install transport chain and torque hardware to specification. See “Transport Chain Connection” in OPERATION section.
- Test run the augers. See “Auger Operation” in OPERATION section.

## **Preparing Tractor**

Before operating cart, read the tractor Operator's Manual and gain an understanding of its safe methods of operation.

Check the tractor brakes and transport lights. Make sure they are in proper working order.

If equipped, check the tractor and cart electric tarp connection. Refer to electric roll tarp manual (291206) for details.

Check if the tractor has multiple PTO engagement modulation settings and has the latest PTO engagement software from the OEM. If unsure, contact your local dealer for tractor capabilities and set to lowest engagement modulation for smoothest operation.

Ensure that PTO engagement setting is set to minimum (or softest) setting.

Check the tractor hydraulic oil reservoir and add oil if needed.

Set tractor drawbar according to the tractor operators manual.

## **Preparing Tractor** (continued)

Verify that the tractor is adequately ballasted for drawbar operation at the anticipated draft load. See tractor manual for ballasting instructions.

If possible, adjust the tractor drawbar vertically so the topside of the drawbar is approximately 17-22 inches from the ground. Ensure that the drawbar is locked in the center position.

**NOTE:** The grain cart comes with a CAT 4 hitch utilizing a 2" diameter pin. A CAT 5 hitch is available for a 2 3/4" diameter pin.

### **CAUTION**

- **USE OF NON-MATCHING CATEGORY HITCH AND TRACTOR DRAWBAR CONNECTION WILL RESULT IN POOR HITCH PERFORMANCE AS WELL AS DAMAGE TO TRACTOR, IMPLEMENT OR BOTH.**

Hitch pin sizes for each Category to help identify which Category drawbar you have.

Category 4	2" Dia. (50 mm)
Category 5	2-3/4" Dia. (70 mm)

On tractors equipped with a 3-point hitch, raise and secure the linkage to prevent interference with the cart tongue, hydraulic hoses and the PTO during turning. It may be necessary to remove tractor 3-point quick attach to avoid damage during turning.

## **Preparing Cart**

Perform the service checks as outlined below. Repair or replace any damaged or worn parts before operating.

### **Hardware**

Check for loose bolts and nuts, and tighten as needed. Check again after the first half-day of operation.

### **Pivot Pins**

Check that all pins are in place and in good condition. Replace any worn, damaged or missing pins.

### **Hitch**

Check hitch wear plates for damage and wear. Be aware of the size of hitch adapter bushing that is being used. Select correct size for the hitch pin/draw bar you are using.

### **Auger**

Inspect auger for damage and wear.



## Preparing Cart (continued)

### Auger Driveline Assembly

Check all bearings, bearing mounts, lock collars, universal joint, front and rear driveshafts for wear or damage. Repair or replace all bearings, bearing mounts, lock collars, universal joint, front and rear driveshafts as necessary. Refer to MAINTENANCE section to verify universal joint and driveline phasing, and for additional information on safe repair and replacement of auger driveline components.

### Soft Start System

Inspect soft start components for wear or damage.

### Hydraulic System

Check all hoses and cylinders for signs of leakage. Hoses should not be kinked, twisted or rubbing against sharp edges. Re-route or repair hoses as necessary. Refer to SAFETY section for additional information on safe repair and inspection of hydraulic components.

### Tires/Wheels

Check tire pressures and maintain at recommended values listed in the MAINTENANCE section of this manual.



## CAUTION

- **IMPROPERLY TORQUED WHEEL NUTS/BOLTS CAN CAUSE A LOSS OF IMPLEMENT CONTROL AND MACHINE DAMAGE. WHEEL NUTS/BOLTS MUST BE CHECKED REGULARLY. SEE TORQUE PAGE IN THE MAINTENANCE SECTION FOR PROPER WHEEL NUT/BOLT SPECIFICATIONS. WARRANTY DOES NOT COVER FAILURES CAUSED BY IMPROPERLY TORQUED WHEEL NUTS/BOLTS.**

## IMPORTANT

- *Installing wheels without the proper inset/offset could result in hub or spindle failure. This will cause substantial damage to cart and is not covered by warranty. Inset/offset will vary depending on tire size. Consult dealer for proper inset/offset*

For questions regarding new tire warranty, please contact your local original equipment tire dealer. Used tires carry no warranty. Tire manufacturers' phone numbers and web sites are listed in the MAINTENANCE section of this manual for your convenience.

## Lubrication

Lubricate the cart as outlined in the MAINTENANCE section of this manual.

## Hitching to Tractor

### Drawbar Connection

This cart is intended to be hitched to a tractor drawbar. Do not attempt to hitch to any other location on the tractor other than the drawbar.

The cart comes with a CAT 4 hitch for use with a 2" pin and designed for a clevis-type tractor drawbar. If a 1 1/2" or 1 3/4" diameter hitch pin is used, a corresponding bushing must be inserted into the hitch tang and held in place with o-rings. (Figure 3-1)

**NOTE:** Use of proper hitch pin/bushing will prevent excessive wear and tear on both the cart and tractor.

**NOTE:** Bushings and o-rings are stored in the toolbox behind the ladder.

**NOTE:** CAT 5 tongue is available for a 2 3/4" diameter pin. Contact your dealer if a CAT 5 tongue/hitch, if required.

Lock tractor drawbar in center position.

Refer to the tractor Operator's Manual for information on tractor drawbar length.

### **WARNING**

- **DO NOT STAND BETWEEN THE CART AND TRACTOR WHEN HITCHING. ALWAYS ENGAGE PARKING BRAKE AND STOP ENGINE BEFORE INSERTING HITCH PINS OR SECURING LATCHES.**

Place wear shoe (281898-CAT 4; 281899-CAT 5) between tractor hitch and grain cart hitch.

After inserting drawbar pin, secure drawbar pin with a locking device to prevent uncoupling during use.

**NOTE:** Cast hitch can be flipped providing a drawbar connection height difference of 2 7/8" (Fig. 3-3). Position the cast hitch to help assure a level cart when loaded, or the rear of the hopper slightly higher than the front, to maintain rear slope cleanout. Whenever the cast hitch is flipped, the driveline clearances needs to be rechecked.

FIG. 3-1

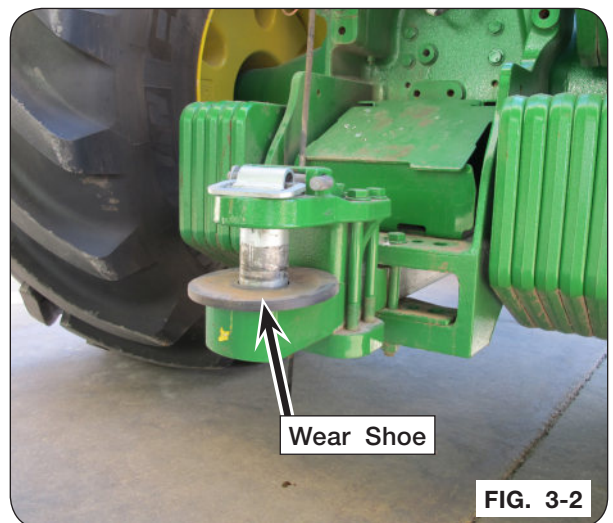
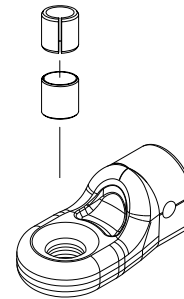
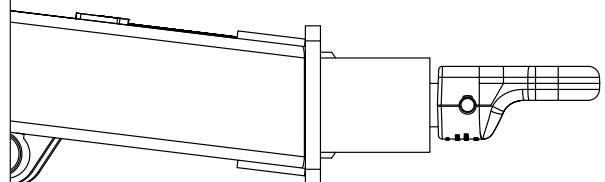


FIG. 3-3

**2 7/8" Higher Than  
The Standard Position**



## Hitching to Tractor (continued)

### Jack Usage

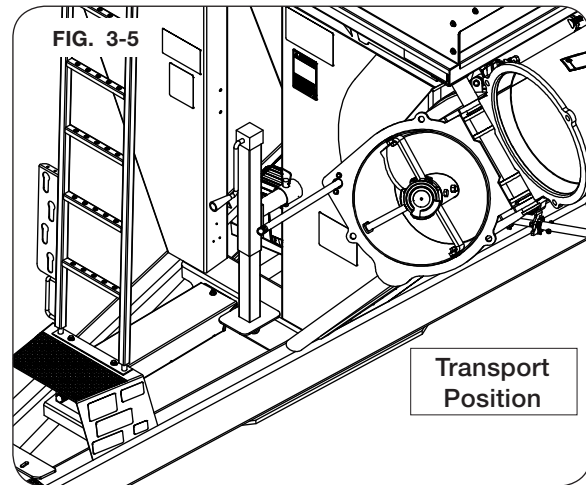
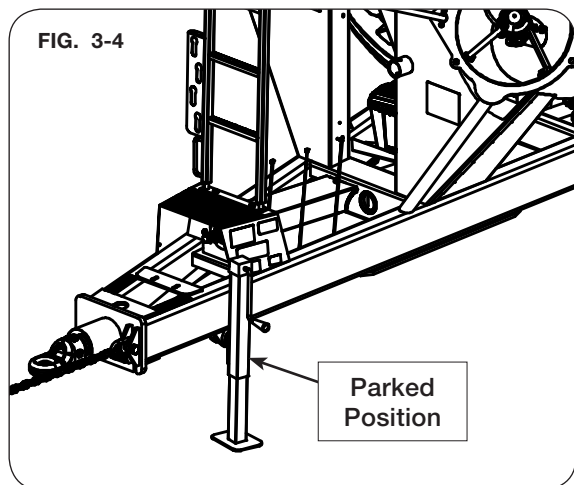
#### **WARNING**

- UNHITCHING A LOADED CART CAN CAUSE SERIOUS INJURY OR DEATH DUE TO THE TONGUE RISING OR FALLING. ALWAYS HAVE A LOADED CART ATTACHED TO A TRACTOR. THE JACK IS INTENDED TO SUPPORT AN EMPTY CART ONLY.

Mount jack in storage position once cart is hitched to tractor. (Fig. 3-4 and 3-5)

#### **IMPORTANT**

- Failure to store the jack in transport position could result in damage to the jack, cart, or tractor tire.



## Hitching to Tractor (continued)

### Optional Hydraulic Jack Usage

#### **WARNING**

- UNHITCHING A LOADED CART CAN CAUSE SERIOUS INJURY OR DEATH DUE TO THE TONGUE RISING OR FALLING. ALWAYS HAVE A LOADED CART ATTACHED TO A TRACTOR. THE JACK IS INTENDED TO SUPPORT AN EMPTY CART ONLY.

Use jack to support an empty grain cart, never a loaded grain cart. Always have a loaded grain cart hooked to tractor.

#### **IMPORTANT**

- After cart is hitched to tractor, attach hydraulic hoses to tractor and fold hydraulic jack up between the frame rails.

Always close the manual valve for the hydraulic jack for in-field use and when unhitching from the tractor. (Fig. 3-6)

1. Remove hoses from storage slots.
2. Attach jack cylinder hoses to tractor.
3. Open valve to allow hydraulic flow.
4. Use tractor hydraulic valve to extend cylinder and lift tongue. Retract cylinder to lower tongue and to raise jack into storage position.
5. Close valve and then disconnect hose couplers from tractor.
6. Place hose couplers into storage caddy. Be sure to route hoses to clear PTO driveline during operation.
7. Check for leaks.

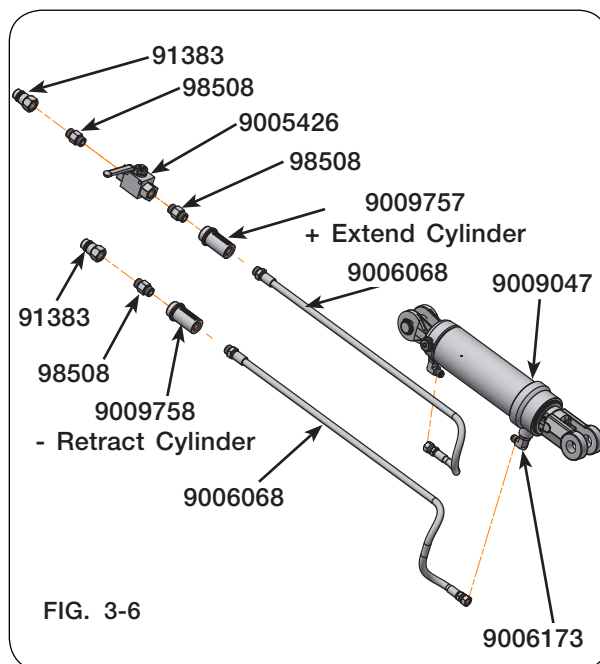


FIG. 3-6

## Hitching to Tractor (continued)

### Transport Chain Connection



## CAUTION

- ALWAYS USE TRANSPORT CHAIN WHEN TRANSPORTING IMPLEMENTS. FAILURE TO USE A TRANSPORT CHAIN COULD CAUSE PERSONAL INJURY IF CART BECOMES DISENGAGED.

---

- REPLACE TRANSPORT CHAIN IF ANY LINK OR END FITTING IS BROKEN, STRETCHED, DAMAGED OR NOT FUNCTIONING. DO NOT WELD TRANSPORT CHAIN.

---

- USE ONLY AN UNVERFERTH ASABE TRANSPORT CHAIN WITH A WEIGHT RATING EXCEEDING THE GROSS COMBINED WEIGHT OF ALL TOWED IMPLEMENTS. CONTACT YOUR UNVERFERTH DEALER FOR ADDITIONAL INFORMATION.

Always use intermediate chain support when connecting the grain cart directly to a tractor. DO NOT use the intermediate chain support as the chain attaching point. See tractor operator's manual for proper chain attachment. Figure 3-7 shows how the transport chain must be installed between the tractor and grain cart.

The transport chain is rated for towing the grain cart empty on public roads. Never tow a loaded grain cart on public roads.



FIG. 3-7

**Hitching to Tractor (continued)**

Clean hydraulic hose couplers before connecting to the tractor. For convenience, it is recommended to connect the flow door circuit hoses to tractor implement coupler #1, auger spout circuit hoses to couplers #2 and #3, and attach auger fold circuit to coupler #4.

This unit is equipped with color-coded grips on the hydraulic hoses. This will help in identifying the hose function and correct hook up.

Color	Hose Function
Red	Flow Door Open (+) and Close (-)
Yellow	Spout Tilt Out (+) and Tilt In (-)
Tan	Spout Rotate Out (+) and In (-)
Green	Auger Unfold (+) and Fold (-)
Black	Jack Raise (+) and Lower (-)
Blue	Water Pump

After initial set-up or replacement of any hydraulic component on the cart, air must be removed from the cart's hydraulic system. Refer to "Hydraulic System" in the MAINTENANCE section for procedure.

Route hoses away from areas that may cause abrasion or kinking of hoses during operation.

Before disconnecting hoses from the tractor, relieve pressure in the system. See the tractor Operator's Manual for the proper procedure. Shut off engine and apply parking brake before disconnecting hoses. Install couplers into storage slots provided. (Fig. 3-8)

**Hydraulic Connections for Hydraulic Drive**

Refer to grain cart's Hydraulic Drive Manual (282894) for installation, operation and parts of the Hydraulic Drive.

**Hydraulic Connections**

Store and keep hydraulic hoses clean. (Fig. 3-8)

**IMPORTANT**

- *When coupling hydraulic hoses to ports on the tractor, be sure that the coupler ends are clean of dust, dirt and debris. Failure to do so could contaminate hydraulic system resulting in excessive wear and possible failure.*

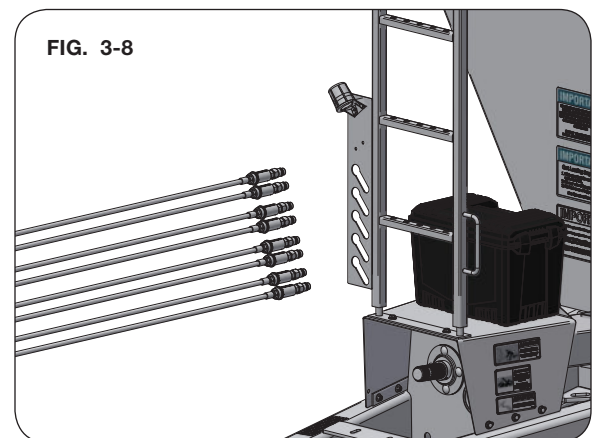
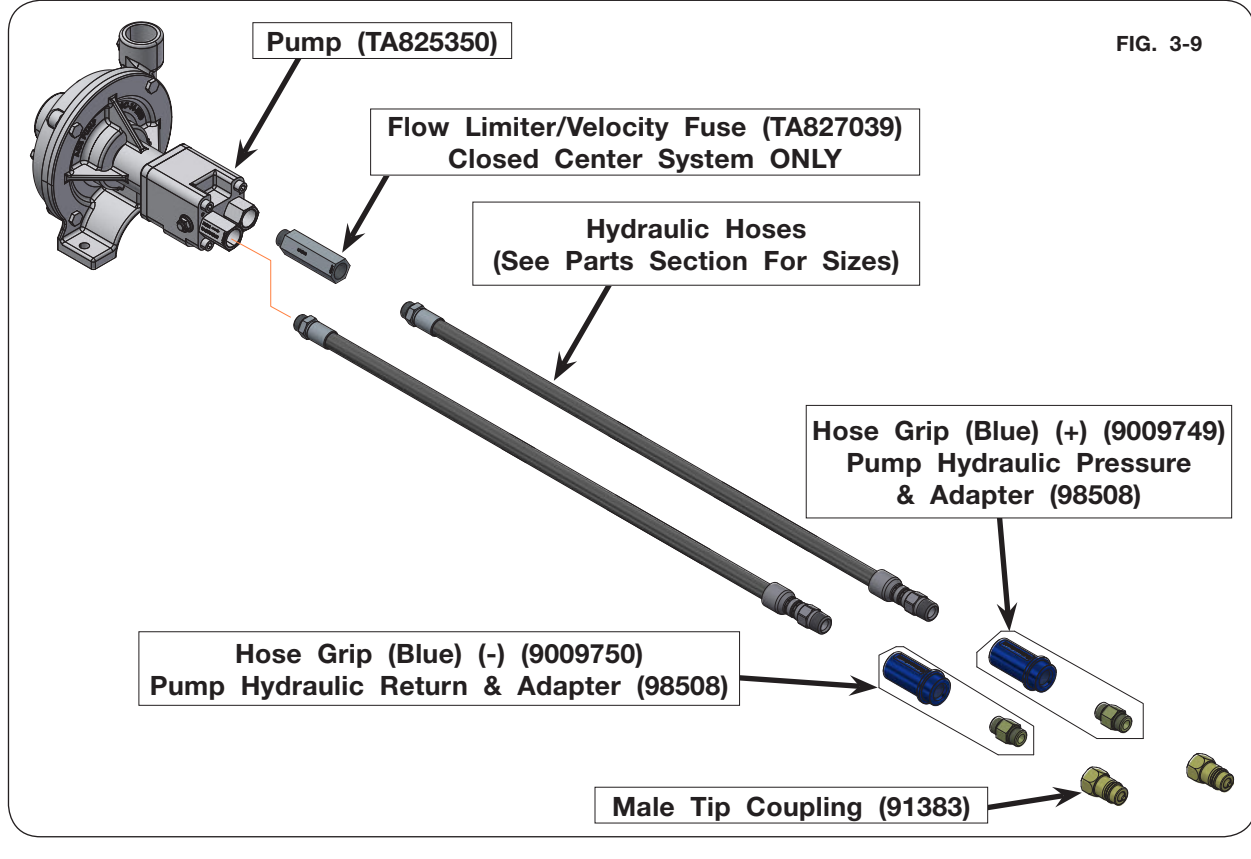


FIG. 3-8

Hitching to Tractor (continued)

Hydraulic Connections For Optional Water Delivery System





## Hitching to Tractor (continued)

### Electrical Connections

This cart is equipped with a seven-pin SAE connector plug that will connect with the receptacle found on most newer tractors. If your tractor does not have this type of receptacle, an SAE J-560 seven-point socket can be purchased from your Unverferth dealer (Part number 92824). (FIG. 3-10)

**NOTE:** The joystick and 7-pin connector **MUST** be plugged into the same power source. If plugged into different power sources, the spout rotate and auger fold functions **WILL NOT** operate normally.

The wiring schematic for this cart, shown in the MAINTENANCE section, complies with ASABE Standards. Always verify correct electrical function before using this cart.

If equipped, check the tractor and cart electrical tarp connection. Refer to electric roll tarp manual (291206) for details.

This unit is equipped with Side Marker lights for enhanced visibility. These lights will have different functionality depending upon the tractor lighting selection.

- When the tractor field lights switch is on; the Side Marker lights and the amber turn signal lights are on solid and will not flash.
- When the flashers and/or turn signal is on; the Side Marker lights flash in unison with their respective side's amber turn lamp.

Compliance with all lighting and marking laws is the responsibility of the operator at the time of travel.

See federal regulation 49 CFR 562; available at [www.govinfo.gov](http://www.govinfo.gov) for US federal law requirements.

See your Unverferth dealer for additional brackets, reflectors, or lights to meet your requirements.

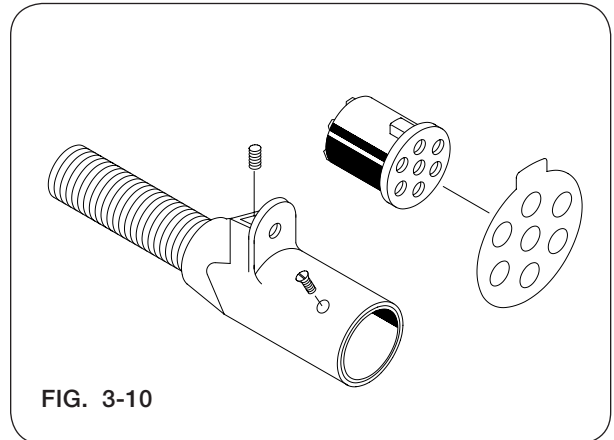


FIG. 3-10

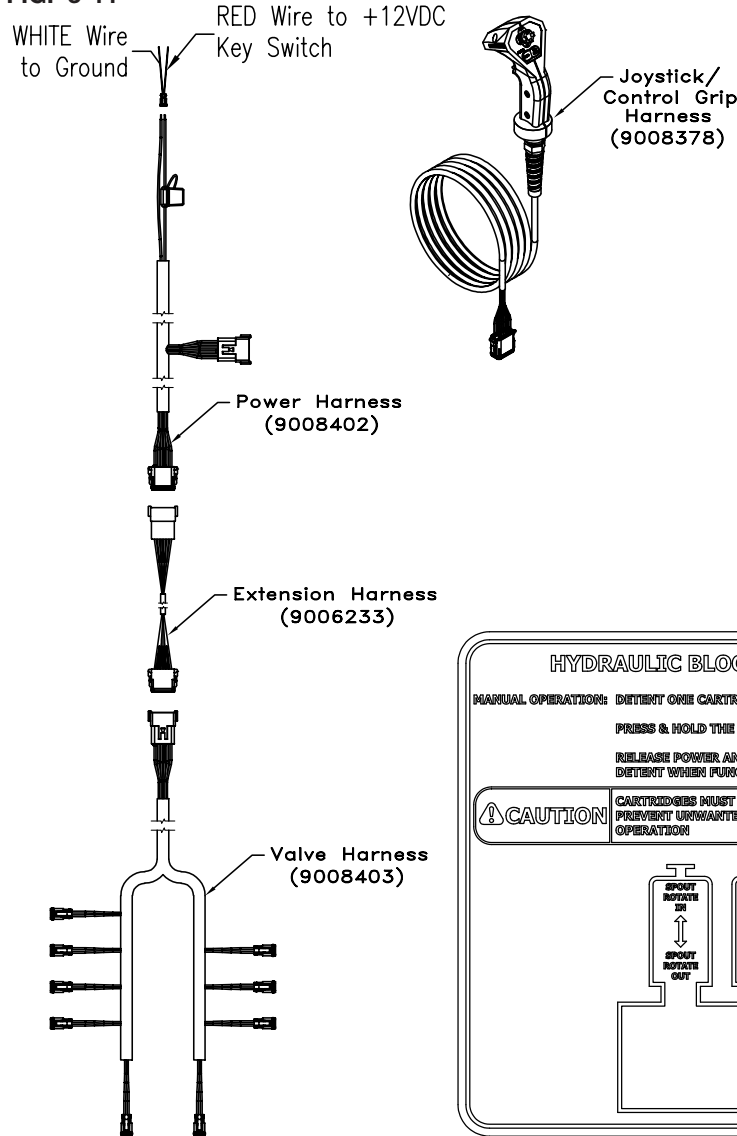
**Optional Electric Over Hydraulic Operation  
Optional - 4 Function**

Before operating cart, familiarize yourself with the functions associated with the joystick controller by operating with an empty cart.

The joystick comes with a mounting pin allowing storage inside the tractor cab when not in use.

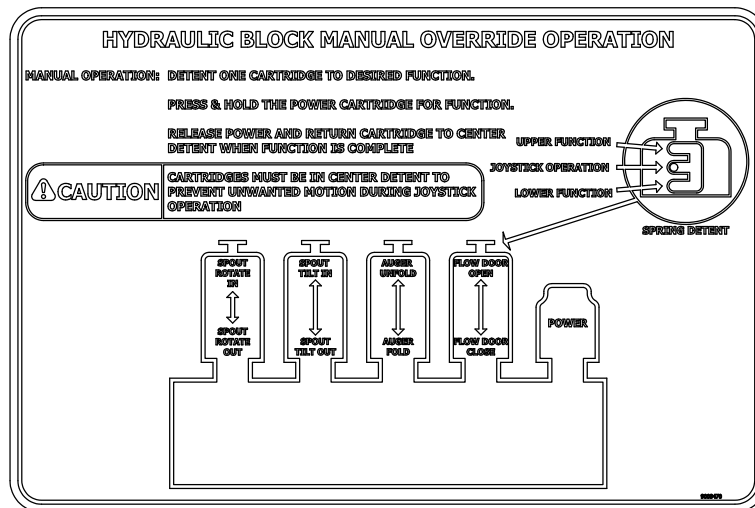
1. Connect the red wire from power harness (9008402) to a key switched +12VDC power supply. (Fig. 3-11)
2. Connect the white wire from power harness (9008402) to ground. (Fig. 3-11)
3. Connect the Hydraulic Pressure and Return hoses to the tractor SCV remote so that the Pressure line is able to be put in continuous detent.
4. Place the remote in continuous detent so that the Hydraulic Pressure hose is pressurized and set the hydraulic flow to a maximum of 6 gal/min. to minimum 4 gal/min.

**FIG. 3-11**



**NOTE:** Consult the tractor's operators manual for proper connection to the Auxiliary Power Outlet in the tractor cab.

**NOTE:** The joystick and 7-pin connector **MUST** be plugged into the same power source. If plugged into different power sources, the spout rotate and auger fold functions **WILL NOT** operate normally.



**Electric Over Hydraulic Operation (Optional) (continued)**

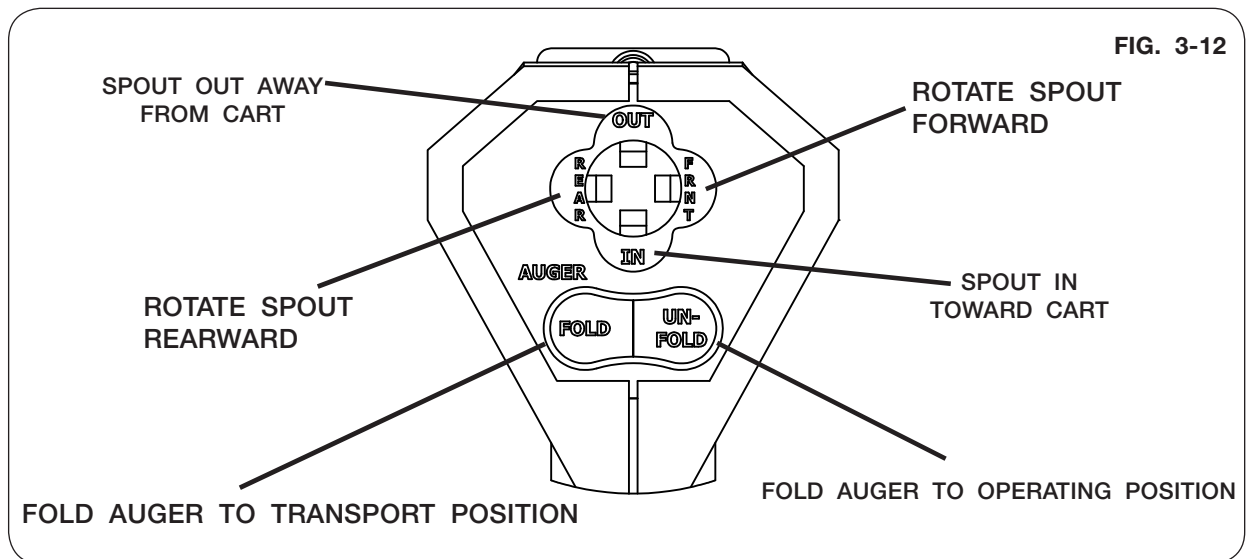
- To fold auger out from transport to operating position, depress the auger unfold button on joystick face until the upper and lower auger are engaged. See FIG. 3-12.

**NOTE:** Joystick has a double tap feature, which allows the operator to quickly double tap a function in order to operate it for a set time. If the auger fold or auger unfold buttons are double tapped, the function will stay on for 60 seconds to complete the full cycle without holding the buttons down. Pressing either of those buttons during these timed cycles will CANCEL the cycle. This double tap feature only applies to auger fold and unfold functions.

- To tilt spout OUT away from cart, push hat switch toward OUT. Hold the switch until desired position is achieved. See in FIG. 3-12.
- To tilt spout IN toward cart, push hat switch toward IN. Hold the switch until desired position is achieved. See in FIG. 3-12.
- To rotate spout FORWARD, push hat switch toward FRNT. Hold the switch until desired position is achieved. See FIG. 3-12.
- To rotate spout REARWARD, push hat switch toward REAR. Hold the switch until desired position is achieved. See FIG. 3-12.

**NOTE:** Refer to “Troubleshooting” for EOH, auger and/or rotating spout issues in the MAINTENANCE section.

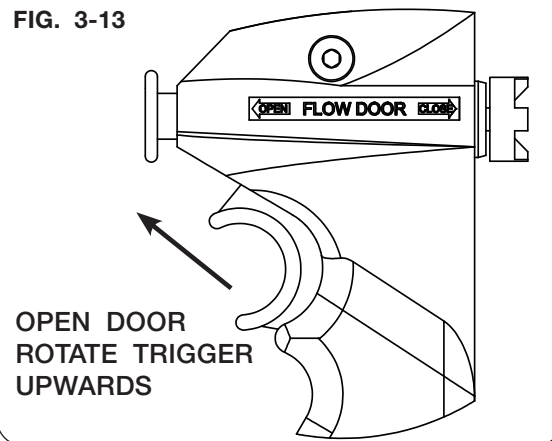
- To fold auger from operating position to transport position, press auger FOLD button on joystick. See FIG. 3-12.



**Electric Over Hydraulic Operation (Optional) (continued)**

11. To open flow door, rotate the switch upwards. Observe flow door indicator to determine when to release trigger and stop flow door movement. See FIG 3-13.

FIG. 3-13

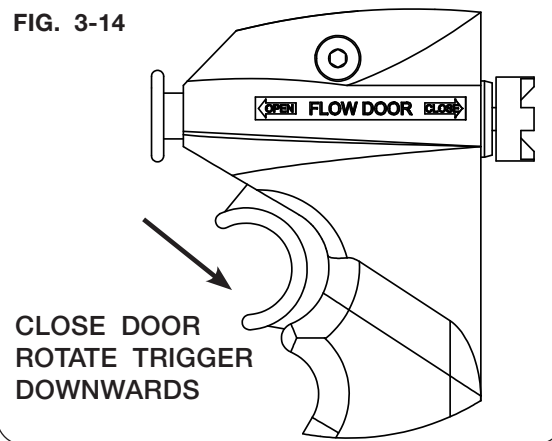


12. To close flow door, rotate the switch downwards. Observe the flow door indicator and release trigger when door is closed to desired position. See FIG. 3-14.

**NOTE:** Refer to “Troubleshooting” for EOH, vertical auger and/or rotating spout issues in the MAINTENANCE section.

13. Once unloading is complete, stop hydraulic flow. **ALWAYS** stop continuous detent when auger functions are not required or active.

FIG. 3-14



## Cart Loading Sequence

### **WARNING**

- NEVER LOAD THE REAR OF A GRAIN CART FIRST. LOAD THE CART EVENLY TO MAINTAIN WEIGHT ON THE TRACTOR DRAWBAR. LOADING ONLY THE FRONT, OR ONLY THE REAR, CAN CAUSE A LOSS OF CONTROL.

---

- TIPPING OR MOVEMENT OF THE MACHINE CAN CAUSE SERIOUS INJURY OR DEATH. BE SURE THE MACHINE IS SECURELY BLOCKED.

---

- UNHITCHING A LOADED CART CAN CAUSE SERIOUS INJURY OR DEATH DUE TO THE TONGUE RISING OR FALLING. ALWAYS HAVE A LOADED CART ATTACHED TO A TRACTOR. THE JACK IS INTENDED TO SUPPORT AN EMPTY CART ONLY.

---

- NEVER ENTER A CART CONTAINING GRAIN. FLOWING GRAIN TRAPS AND SUFFOCATES VICTIMS IN SECONDS.

1. Ensure auger flow door is closed before loading cart.
2. Fill the cart starting just forward of the axle until nearly full.

**NOTE:** Overfilling the front or rear area of the hopper can result in reduced control of the cart when towing.

3. Fill the rear area of the hopper before topping off the front area. This maintains proper weight on the hitch of the tractor.

## **Towing**

Ensure that the towing vehicle has adequate weight and braking capacity to tow this implement and all attachments. See your Unverferth dealer for more information. See towing vehicle's operators manual for towing capacity. Never tow a loaded grain cart over public roads.

Do not exceed 10 m.p.h. during off-highway travel. Do not exceed 8 m.p.h. when cart is fully loaded. These speeds apply to both tires and tracks.

Secure drawbar pin with a retaining device and lock tractor drawbar in centered position. Connect the PTO driveshaft to the tractor.

Secure transport chain through the chain support and to the tractor frame before towing.

### **CAUTION**

- **THE STANDARD TRANSPORT CHAIN IS DESIGNED ONLY FOR AN EMPTY GRAIN CART DURING ROAD TRAVEL.**
- 

Rotate the directional spout to the narrowest transport width position.

It is probable that this cart is taller, wider and longer than the towing tractor. Become aware of and avoid all obstacles and hazards in the travel path of the equipment, such as power lines, ditches, etc.

Always have the auger folded back into storage position when not in use.

To prevent damage during turning when using non-PTO equipped towing vehicles, store the PTO driveshaft in the brackets provided on the right-hand side frame rail.

## Auger Operation

### DANGER

- ELECTROCUTION WILL CAUSE SERIOUS INJURY OR DEATH. ELECTROCUTION CAN OCCUR WITHOUT DIRECT CONTACT. KEEP AWAY FROM ALL ELECTRICAL LINES AND DEVICES.



- ENTANGLEMENT WITH THE DRIVELINE WILL CAUSE SERIOUS INJURY OR DEATH. KEEP ALL GUARDS AND SHIELDS IN GOOD CONDITION AND PROPERLY INSTALLED AT ALL TIMES. AVOID PERSONAL ATTIRE SUCH AS LOOSE FITTING CLOTHING, SHOE STRINGS, DRAWSTRINGS, PANTS CUFFS, LONG HAIR, ETC. THAT CAN BECOME ENTANGLED IN A ROTATING DRIVELINE.

1. Before loading cart or operating auger, verify that the flow control door is closed.
2. Choose an area free from obstructions and unfold auger into unloading position. Allow sufficient time for the cylinder to fully engage the two augers.

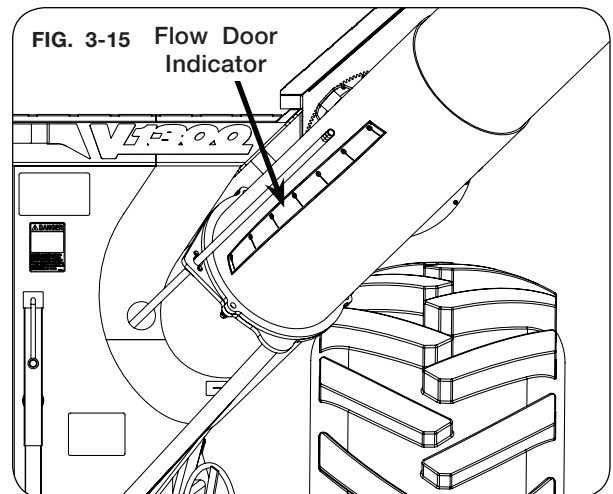
**NOTE:** Minimum of 1,000 PTO RPM MUST be maintained when operating the flow door at the maximum setting.

3. Engage tractor PTO at low engine RPM, then increase engine RPM until 1,000 PTO RPM is reached.

### IMPORTANT

- Operating the PTO at less than 1,000 RPM can result in damage to the PTO and driveline components in addition to excessive auger wear and cart vibration.
4. Open flow control door to desired unloading rate. Numbers on the auger tube provide a point of reference for operator convenience. (FIG. 3-15)

(Continued on next page.)



**NOTE:** If an overload occurs, (excessive heat/smoke or a ratcheting or “clicking” noise from the cut-out clutch) shut off PTO immediately. Close flow control door and relieve auger grain pressure by opening cleanout door to remove some grain from auger before resuming. When resuming operation, allow clutch to cool, then engage tractor PTO at low engine RPM, and increase engine RPM until 1,000 PTO RPM is reached.

**NOTE:** For maximum flow of material, the factory-adjusted cylinder stop may be moved. See “Auger System - Auger Flow Door Stop” in MAINTENANCE.



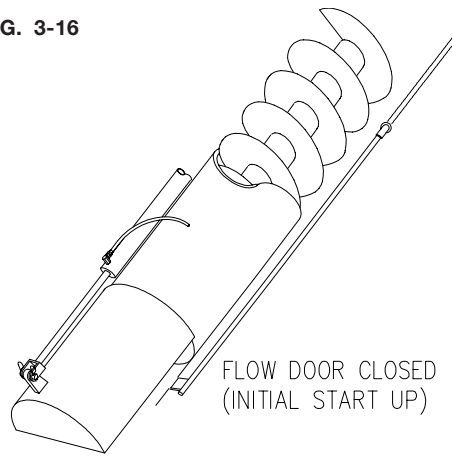
**Auger Operation (continued)**

5. To slow or stop grain flow, close flow door, DO NOT reduce tractor/PTO RPM as a means to control grain flow. Close flow door fully when unloading is complete. (FIG. 3-16)

**NOTE:** It is not recommended to disengage auger with flow control door open. Auger system will require substantially more torque to start, placing extra stress on both cart and tractor driveline.

6. Reduce tractor RPM to idle, then stop PTO. After the PTO has come to a complete stop, fold auger to the transport position.

**FIG. 3-16**



## Rear Ladder Operation

### **WARNING**

- **FALLING OR LOWERING EQUIPMENT CAN CAUSE SERIOUS INJURY OR DEATH. KEEP EVERYONE AWAY FROM EQUIPMENT WHEN SUSPENDED, RAISING, OR LOWERING.**
- **DO NOT ALLOW ANYONE TO RIDE ON THE LADDER. MAKE SURE EVERYONE IS CLEAR BEFORE OPERATING MACHINE OR TOWING VEHICLE.**
- **KEEP HANDS CLEAR OF PINCH POINT AREAS.**
- **TO PREVENT PERSONAL INJURY OR DEATH, ALWAYS ENSURE THAT THERE ARE PEOPLE WHO REMAIN OUTSIDE THE CART TO ASSIST THE PERSON WORKING INSIDE, AND THAT ALL SAFE WORKPLACE PRACTICES ARE FOLLOWED. THERE IS RESTRICTED MOBILITY AND LIMITED EXIT PATHS WHEN WORKING INSIDE THE IMPLEMENT.**
- **NEVER ENTER A CART CONTAINING GRAIN. FLOWING GRAIN TRAPS AND SUFFOCATES VICTIMS IN SECONDS.**

**NOTE:** Ensure ladder and steps are free from snow/debris before changing ladder positions and climbing.

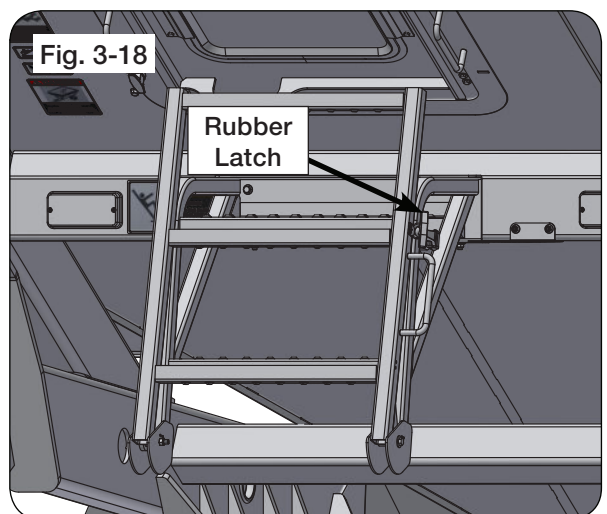
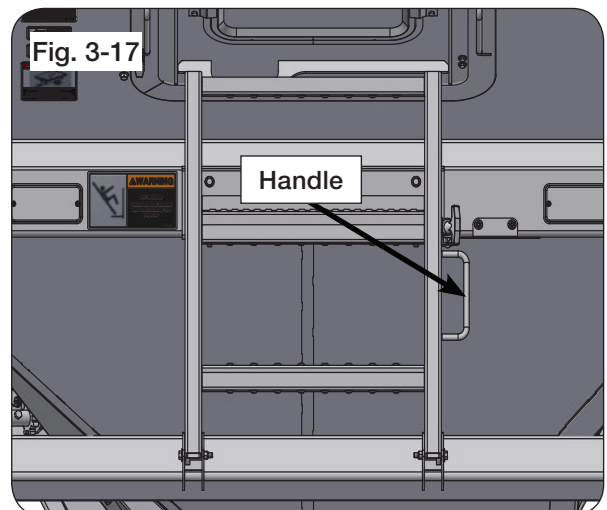
**NOTE:** Lower ladder section must be raised and locked in the storage position when not used.

### Unfolding Ladder

1. Park the empty grain cart on a firm and level surface. Block the machine to keep it from moving. Set the tractor's parking brake, shut-off the engine, remove the ignition key and disconnect the PTO shaft.

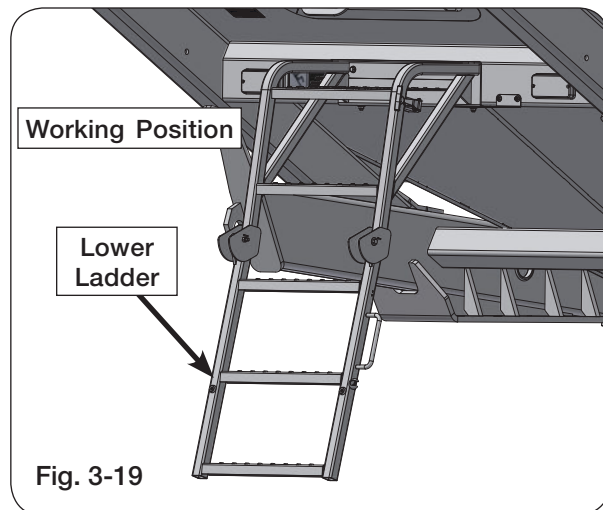


2. While holding ladder handle, remove rubber latch from holder. (FIG. 3-17 and 3-18)



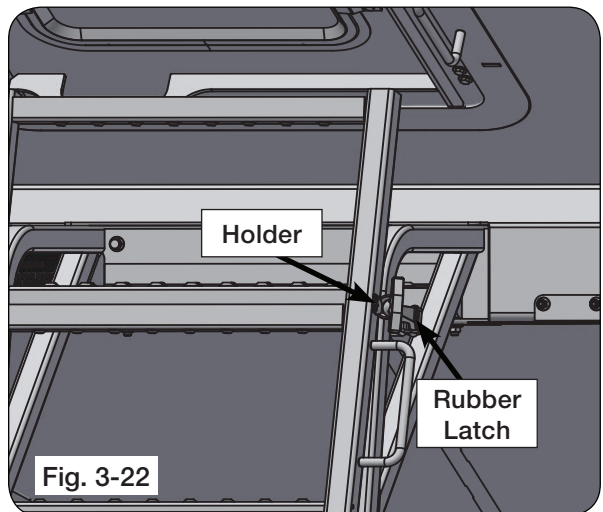
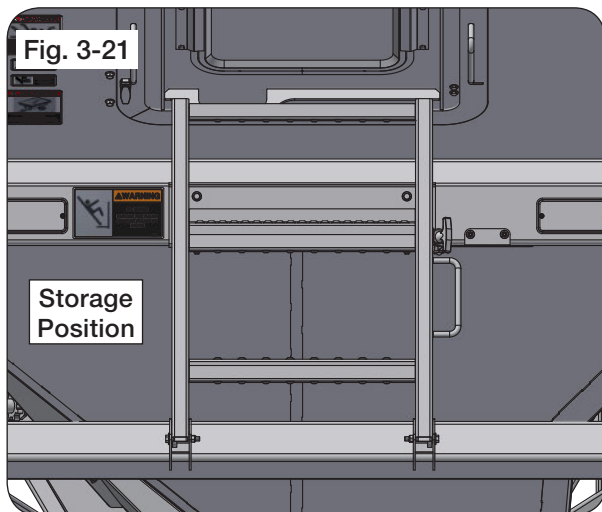
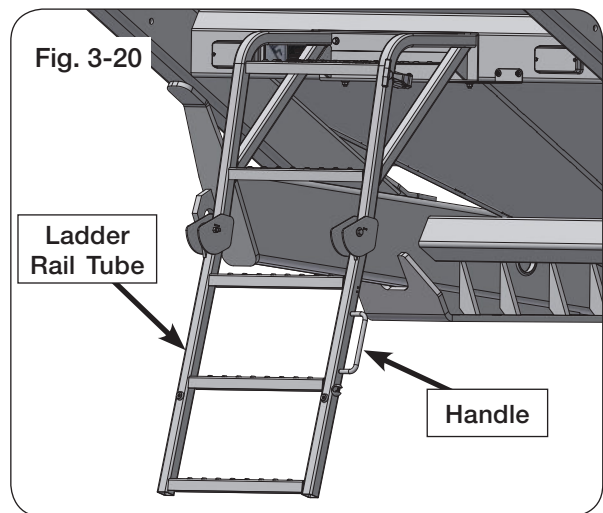
### Rear Ladder Operation (continued)

3. While holding ladder handle, slowly swing the lower ladder section completely down to working position (FIG. 3-19)



### Folding Ladder

1. Slowly lift and swing the lower ladder section up to storage position. (FIG. 3-20)
2. While holding ladder handle, fasten rubber latch into holder to lock ladder in storage position. (FIG. 3-21 and 3-22)



## Rear Access Door Operation

### **WARNING**

- ENSURE SCREENS OVER HORIZONTAL AUGERS ARE IN PLACE AND PROPERLY SECURED.
- KEEP HANDS CLEAR OF PINCH POINT AREAS.
- TIPPING OR MOVEMENT OF THE MACHINE CAN CAUSE SERIOUS INJURY OR DEATH. BE SURE THE MACHINE IS SECURELY BLOCKED.
- EYE PROTECTION AND OTHER APPROPRIATE PERSONAL PROTECTIVE EQUIPMENT MUST BE WORN WHILE SERVICING THE IMPLEMENT.

1. Park the empty grain cart on a firm and level surface. Block the machine to keep it from moving. Set the tractor's parking brake, shut-off the engine, remove the ignition key and disconnect the PTO shaft.

2. Maintain contact with either left or right side hand grabs then turn both door latches counter clockwise to unlatch door. (Fig. 3-23)



3. Push in on bottom door handle to open rear access door. (Fig. 3-24)

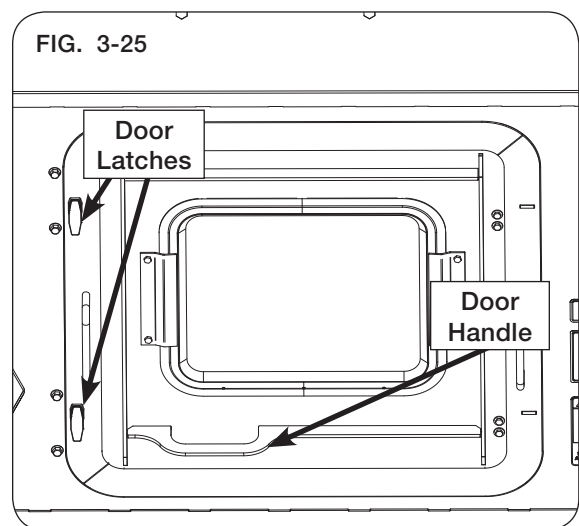
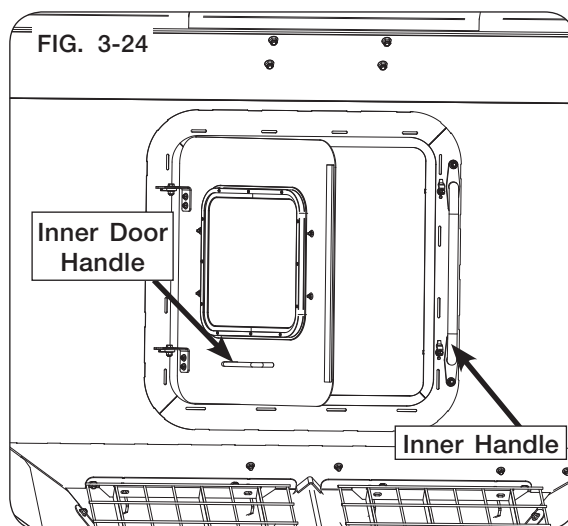
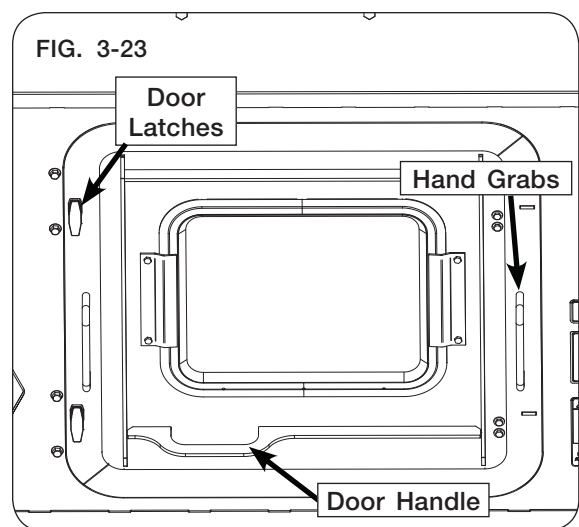
4. Push rear access door inward until it stops.

5. Use hand grabs to enter the cart.

6. Use inner handle to exit cart. (Fig. 3-24)

7. Use door handle to close the rear access door. (Fig. 3-25)

8. Turn both door latches clockwise to lock the rear access door. (Fig. 3-25)



## Weather Guard Tarp

### **WARNING**

- **TO PREVENT PERSONAL INJURY OR DEATH, DO NOT ALLOW ANYONE ON A CLOSED TARP. TARP SYSTEM IS NOT DESIGNED TO SUPPORT A PERSON.**

---

- **FALLING OBJECTS CAN CAUSE SERIOUS INJURY OR DEATH. REMOVE ACCUMULATED WATER/SNOW/ICE OR ANY OTHER OBJECTS FROM TARP BEFORE OPENING TARP.**

---

### **IMPORTANT**

- *Do not open or close tarp while moving or in high wind conditions. Damage to the tarp may occur.*
- *Tarp should not be used if it is torn or the bungee cords are frayed or show damage. Fully close tarp with tension on the latch plate to prevent water from pooling.*

Always use caution when operating tarp.

If equipped, refer to electric roll tarp manual (291206) for operation details.

Open and close the tarp evenly.

Make sure tarp is open before loading.

Make sure all persons are clear of the tarp system before and during operating.

Do not operate tarp with cart hoisted in an elevated position.

Remove any ice or snow before operating.

End caps must be free from grain that may be piled on them. Grain should not be heaped higher than the end caps or tarp bows.

Tarp may be fully opened or completely closed while in transit. However, the closed position is recommended.

Ensure everyone who operates the tarp is familiar with the correct procedures outlined in this manual.

### Weather Guard Tarp (continued)

**NOTE:** If equipped with wireless electric roll tarp, skip to next page. For weather guard tarp, continue to step 1.

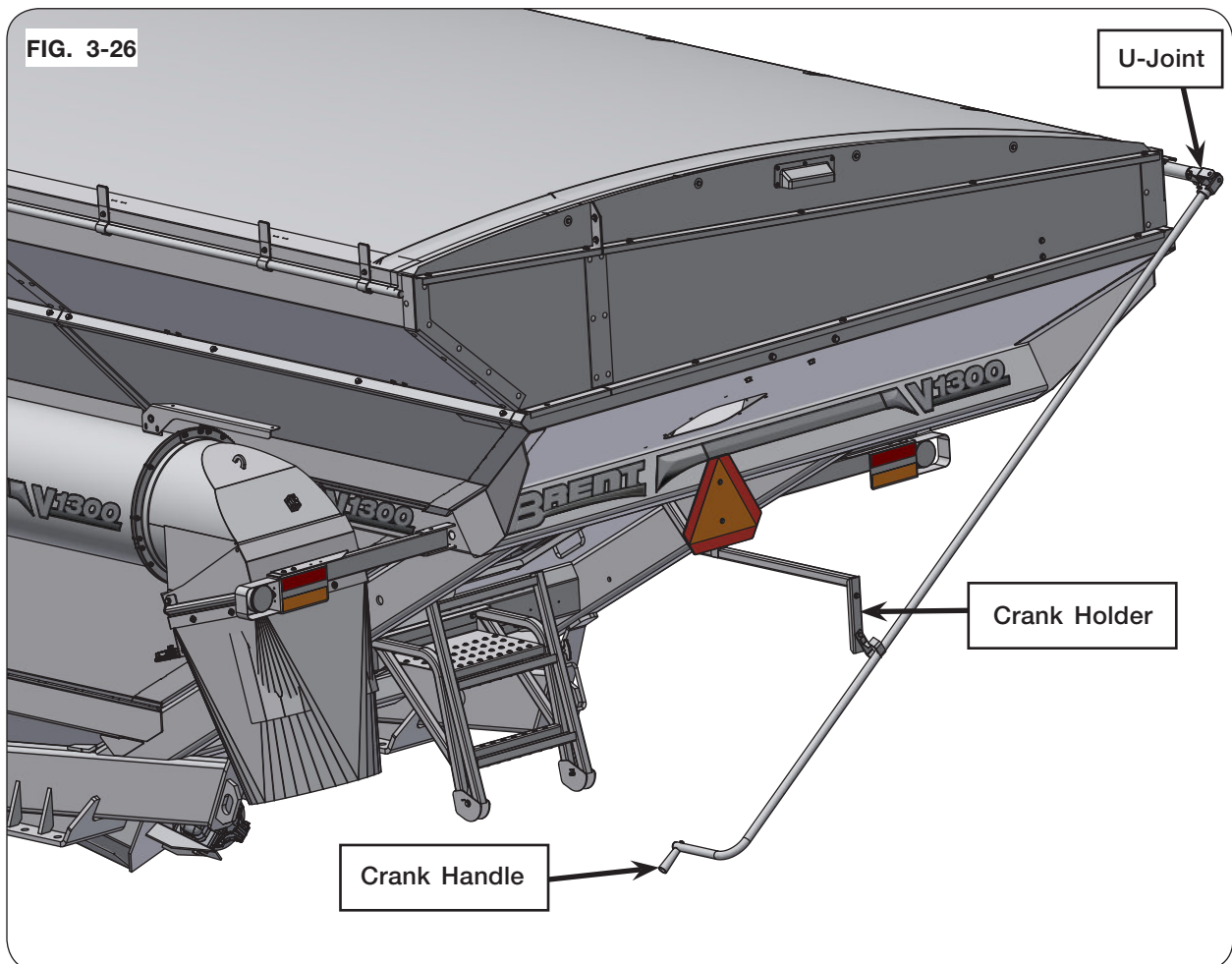
1. Using both hands, carefully remove tarp handle weldment from tube holder. (FIG. 3-26)
2. Roll tarp to the desired location, choosing either a fully open or fully closed position.
3. To close the tarp, rotate the roll tube clockwise up under the latch plate.
4. Make sure tarp is positioned evenly over latch plate length.

**NOTE:** Do not tighten if tarp overlaps end of the latch plate. Tearing of the tarp may occur. Reposition tarp, as necessary.

5. Bring the tarp handle weldment down perpendicular to the ground. Continue by lifting it up into the tube holder.

**NOTE:** Tarp handle weldment U-joint may need to be re-indexed on roll tube to achieve correct tension.

6. To open tarp, turn the roll tube counter clockwise until the tarp is fully open. Place tarp handle weldment in tube holder.



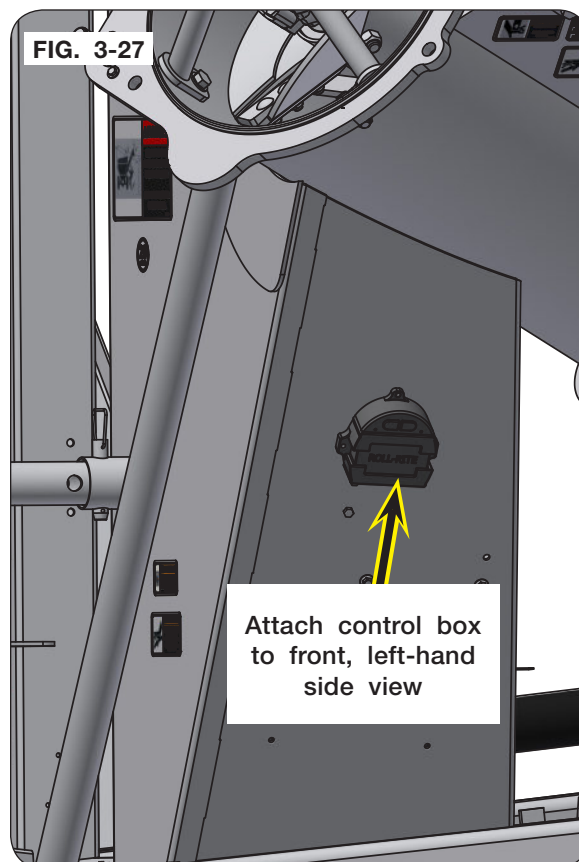


## Weather Guard Tarp (continued)

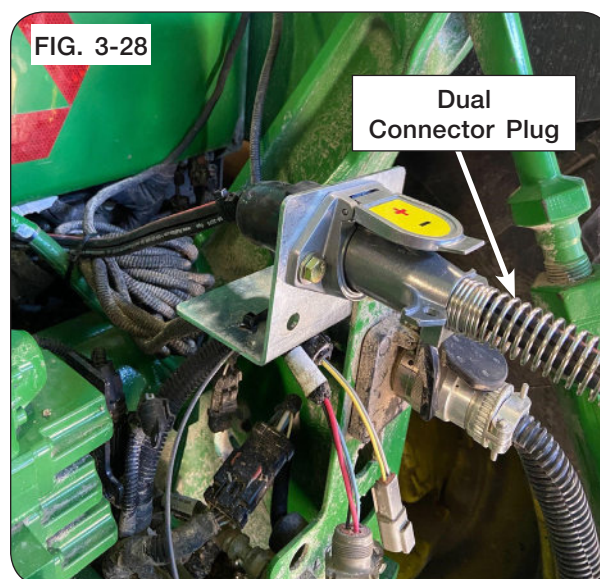
### Electric Tarp Wireless Receiver and Control Box Location

**NOTE:** Refer to electric roll tarp manual (291206) for wireless operation details.

1. Position the control box on the cart to front, left-hand side support as shown in figure 3-27. If the holes are not predrilled, mark and drill the three 5/16" holes.
2. Secure control box to cart with hardware provided. (Fig. 3-27)
3. Route wire up to the front of the cart to the hose holder.



4. Dual connector plug (9005327) attaches to the socket on the back of the tractor as shown. (Fig. 3-28)
5. When electric tarp is not in use, place connector plug into storage caddy. Be sure to route connector plug harness to clear PTO driveline during operation.





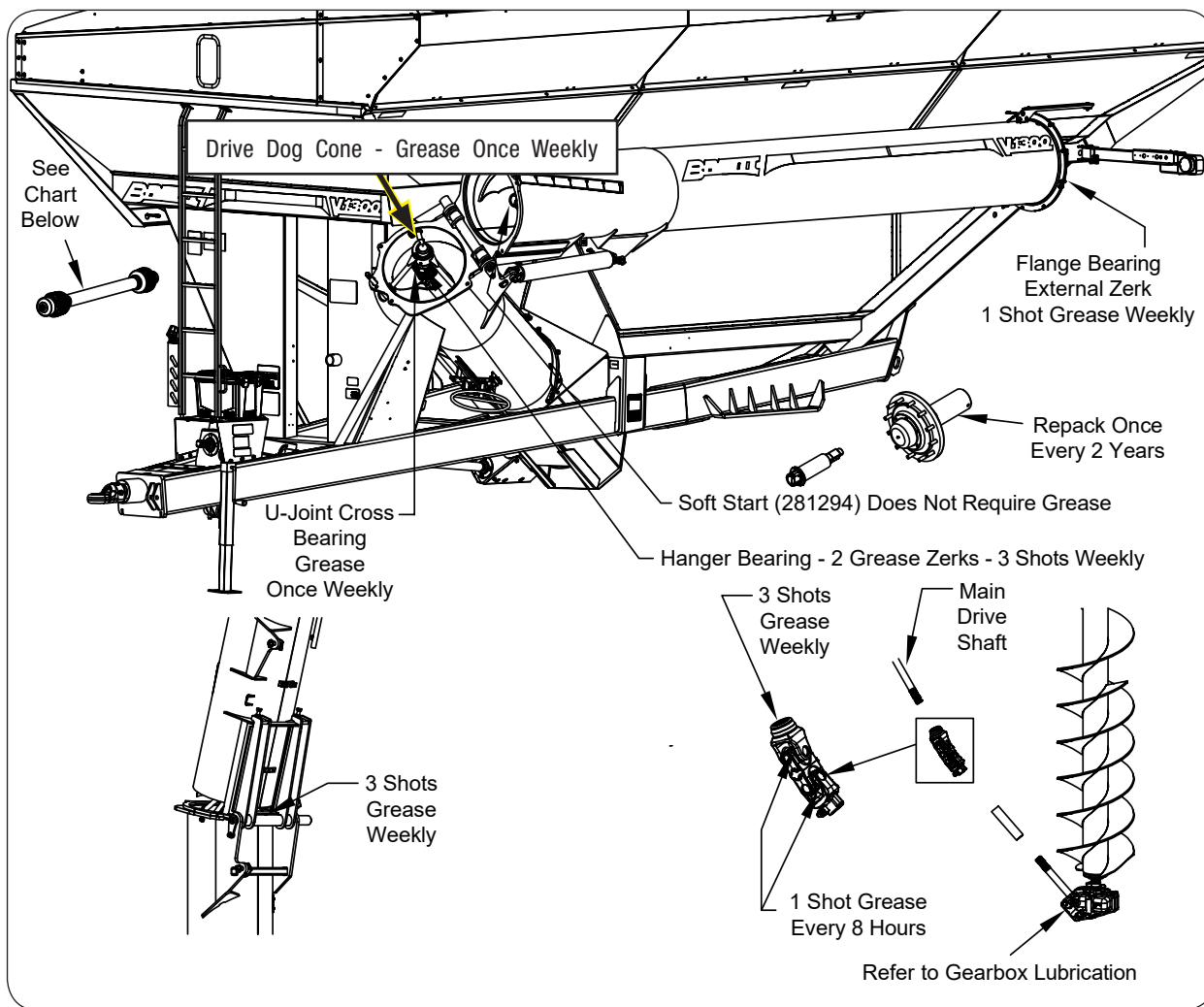
## **Section IV Maintenance**

Lubrication.....	4-2
Gearbox Lubrication .....	4-3
Hydraulic System .....	4-4
Purge Hydraulic System .....	4-4
Manual Override for Optional Electric Over Hydraulic System .....	4-5
Auger System.....	4-8
Lower Auger .....	4-8
Lower Auger Removal.....	4-8
Lower Auger Assembly .....	4-9
Hanger Bearing Centering.....	4-10
Lower Auger Timing.....	4-10
U-Joint Spline Gap.....	4-11
Upper Auger.....	4-12
Upper Auger Removal.....	4-12
Soft Start Replacement.....	4-13
Upper Auger Timing .....	4-13
Upper Auger Height .....	4-15
Upper Auger Bearing Gap .....	4-16
Auger Flow Door Cylinder Replacement .....	4-17
Auger Floor Door Cylinder Stop.....	4-20
Auger Driveline.....	4-21
Adjusting Cleanout Door .....	4-27
Verify Telescoping PTO Shaft Length .....	4-29
PTO Shaft and Clutch.....	4-31
PTO Quick Disconnect .....	4-34
Wheels, Hub and Disassembly and Assembly.....	4-35
Wheels and Tires - Wheel Nut Torque .....	4-37
Wheels and Tires - Tire Pressure.....	4-38
Wheels and Tires - Tire Warranty.....	4-39
Seasonal Storage .....	4-40
Hydraulic Jack Cylinder Replacement.....	4-42
Troubleshooting.....	4-44
Tarp Troubleshooting Inspection & Maintenance .....	4-46
Electrical System Diagram.....	4-47
Hydraulic System Plumbing Diagram.....	4-58
Torque Chart - Hardware .....	4-59
Hydraulic Fittings - Torque and Installation.....	4-61

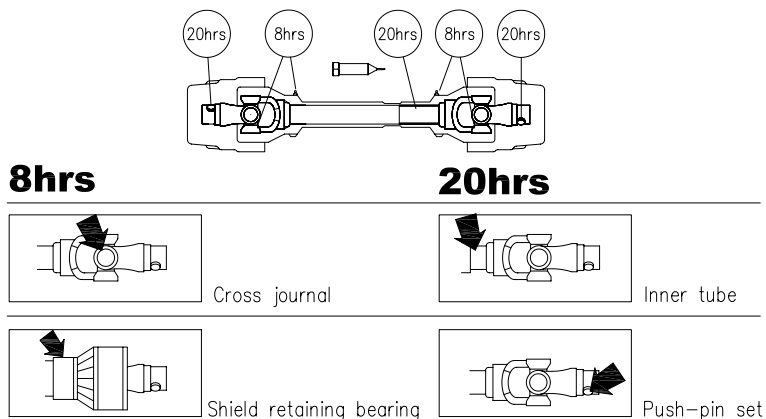
FOR SCALE, TRACK, UHARVEST, HYDRAULIC DRIVE, ELECTRIC TARP, AND / OR WATER DELIVERY SYSTEM INFORMATION, PLEASE REFER TO THE INDIVIDUAL MANUALS.

## Lubrication

To keep your grain cart in top operating condition and to assure its proper performance and reliability for a long period of time, periodic inspection and lubrication is a must. Make sure to use NLGI-2 high quality EP grease.



### LUBRICATION INSTRUCTIONS FOR DRIVE LINE

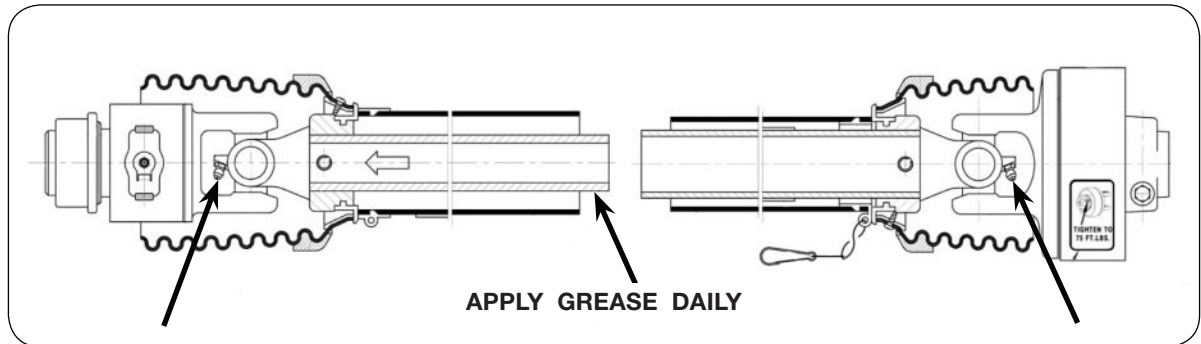


COAT INNER AND OUTER PROFILES AT BEGINNING AND END OF EACH SEASON

### Lubrication (continued)

Lubricate with quality grease before starting work and every 8 operating hours. Clean and grease PTO drive shaft before each prolonged period of non-use. Molded nipples on the shield near each shield bearing are intended as grease fittings and should be lubricated every 8 hours of operation! Check and grease the guard tubes in winter to prevent freezing.

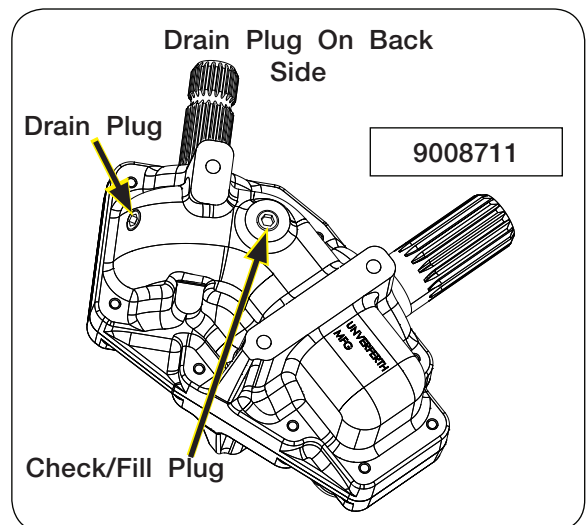
**NOTE:** Telescoping members must have lubrication to operate successfully regardless of whether a grease fitting is provided for that purpose! Telescoping members without fittings should be pulled apart and grease should be added manually.



### Gearbox Lubrication

Gearbox check/fill plug is located on the right hand front side of the housing. To check oil fluid level, place cart on a level surface with the tongue elevated to hitch height and remove the plug. Oil level should be at the bottom thread.

**For Maximum gearbox life:**  
Check oil level every 2 weeks.  
Replace oil every season with 73 fl. oz. of 80W90 EP gear lubricant.



## Hydraulic System

Refer to parts section for hydraulic component detail listing.

When properly assembled and maintained, the hydraulic system of the grain cart requires little maintenance.

Replacing Hoses/Fittings/Cylinders:

1. Use replacement hoses, fittings, and cylinders from your Unverferth Manufacturing dealer which are rated for 3000 psi.
2. Do not use hoses, fittings and cylinders that have pipe threads.
3. Do not use Teflon tape or thread sealant on JIC or O-ring fittings. Tighten fittings according to “Torque Chart” in this section.
4. When replacing hoses, always allow sufficient slack to permit hoses to move through the full range of motion of the cylinders.
5. Always purge the hydraulic system after servicing.

## Purge Hydraulic System

### **WARNING**

- **RELIEVE HYDRAULIC SYSTEM OF ALL PRESSURE BEFORE ADJUSTING OR SERVICING. SEE THE HYDRAULIC POWER UNIT OPERATOR’S MANUAL FOR PROPER PROCEDURES.**
- **HIGH-PRESSURE FLUIDS CAN PENETRATE THE SKIN AND CAUSE SERIOUS INJURY OR DEATH. LEAKS OF HIGH-PRESSURE FLUIDS MAY NOT BE VISIBLE. USE CARDBOARD OR WOOD TO DETECT LEAKS IN THE HYDRAULIC SYSTEM. SEEK MEDICAL TREATMENT IMMEDIATELY IF INJURED BY HIGH-PRESSURE FLUIDS.**



Purge air from system as follows:

- A. Clear all personnel and objects from the area, including where the machine will have full range of motion during the hydraulic movement. Remove transport locks from the machine.
- B. Pressurize the system and maintain the system at full pressure for at least 5 seconds after the cylinder rods stop moving, or hydraulic motors have completed the required movement. Check that all movements are fully completed.
- C. Check oil reservoir in the hydraulic power source and refill as needed.
- D. Pressurize the system again to reverse the motion of step B. Maintain pressure on the system for at least 5 seconds after the cylinder rods stop moving, or hydraulic motors have completed the required movement. Check that all movements are fully completed.
- E. Check for hydraulic oil leaks using cardboard or wood. Tighten connections according to directions in the Torque Specifications in the MAINTENANCE section.
- F. Repeat steps in B, C, D, and E 10-12 times.

### **IMPORTANT**

- *Machine damage will occur if the cylinder is incorrectly installed.*

Check for and correct any leaks. Make sure hoses are not kinked, stretched, or twisted. Secure hoses to prevent cuts or chafing during operation.

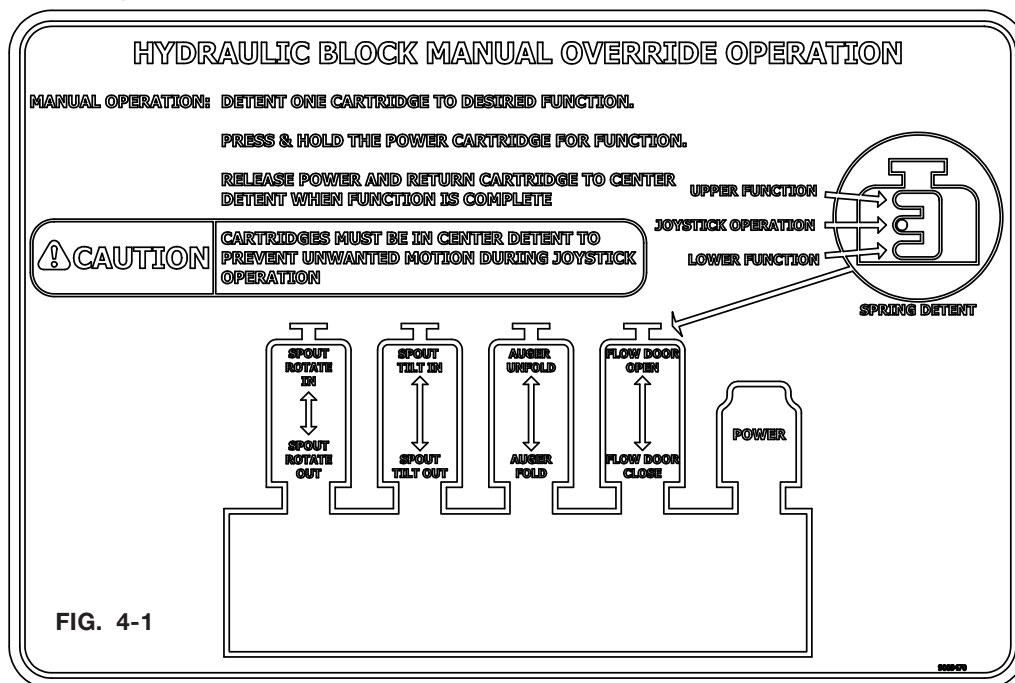
## Manual Override for Optional Electric Over Hydraulic System

### **⚠ WARNING**

- MOVING OR ROTATING AUGER COMPONENTS CAN CAUSE SERIOUS INJURY OR MACHINE DAMAGE. BEFORE OPERATING MANUAL OVERRIDE(S), ENSURE EVERYONE IS AWAY FROM THE SPOUT AND THAT THE SPOUT WILL NOT CONTACT ANY OTHER PARTS OF THE GRAIN CART.
- MOVING OR ROTATING PTO COMPONENTS CAN CAUSE SERIOUS INJURY OR DEATH. DO NOT OPERATE PTO WHILE UTILIZING MANUAL OVERRIDE(S).
- ALL SAFETY SWITCHES ARE DEACTIVATED WHILE UTILIZING MANUAL OVERRIDE(S).

**NOTE:** 7-pin connector must be plugged into the tractor in order for the EOH system to operate.

**NOTE:** Manual override operation is intended for emergency use **ONLY** and is not intended for continuous operation.



1. Park the empty grain cart on a firm and level surface. Block the machine to keep it from moving. Set the tractor's parking brake.
2. Connect the Hydraulic Pressure and Return hoses to the tractor SCV remote so that the Pressure line is able to be put in continuous detent.
3. To operate the manual override functions, place the tractor SCV remote in continuous detent so that the Hydraulic Pressure hose is pressurized.

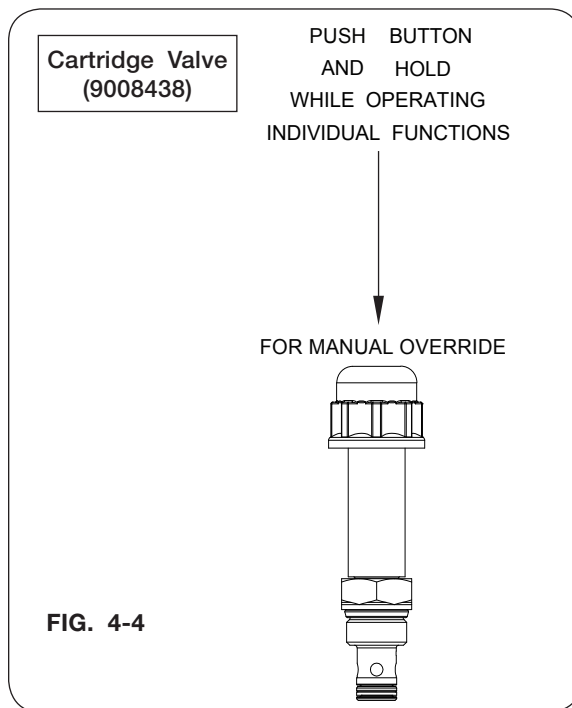
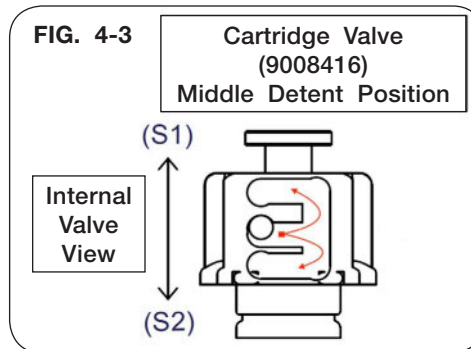
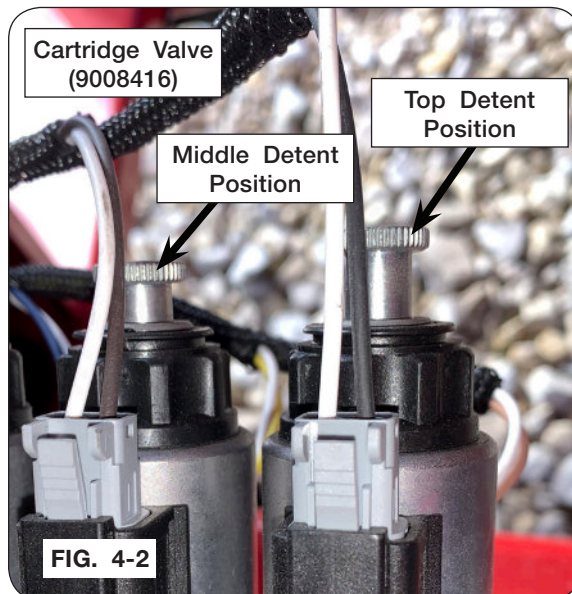
(Continued on next page)

**Manual Override for Optional Electric Over Hydraulic System**  
(continued)

**NOTE:** Only one cartridge valve (9008416) may be in the top or bottom detent position at a time to function properly. All other valves must be in the middle detent position. (FIG 4-2 & 4-3)

4. Locate desired function on valve (9008416) then move cartridge to top/bottom detent, as desired, and lock in position. (FIG. 4-2)
5. Push and hold the power cartridge on valve (9008438). (FIG. 4-4)
6. Once the desired position is reached, release manual override button on valve (9008438).
7. Return cartridge to center and lock valve (9008416) in position. (FIG. 4-2 & 4-3)
8. Turn off hydraulic circuit when done. Correct electric/hydraulic system before continued use. Consult your dealer for service and parts.

**NOTE:** Refer to “Troubleshooting” for EOH, auger and/or rotating spout issues in the MAINTENANCE section.



## Auger System

### **WARNING**

- TO PREVENT PERSONAL INJURY OR DEATH, ALWAYS ENSURE THAT THERE ARE PEOPLE WHO REMAIN OUTSIDE THE CART TO ASSIST THE PERSON WORKING INSIDE, AND THAT ALL SAFE WORKPLACE PRACTICES ARE FOLLOWED. THERE IS RESTRICTED MOBILITY AND LIMITED EXIT PATHS WHEN WORKING INSIDE THE IMPLEMENT.

---

- NEVER ENTER CART WITH AUGER OR TRACTOR RUNNING. SERIOUS OR FATAL INJURY CAN OCCUR DUE TO ENTANGLEMENT WITH ROTATING COMPONENTS. ALWAYS STOP ENGINE AND REMOVE KEY BEFORE ENTERING CART.

---

- KEEP HANDS CLEAR OF PINCH POINT AREAS.

---

- EYE PROTECTION AND OTHER APPROPRIATE PERSONAL PROTECTIVE EQUIPMENT MUST BE WORN WHILE SERVICING IMPLEMENT.

---

- FALLING OBJECTS CAN CAUSE SERIOUS INJURY OR DEATH. DO NOT WORK UNDER THE MACHINE AT ANY TIME WHILE BEING HOISTED. BE SURE ALL LIFTING DEVICES AND SUPPORTS ARE RATED FOR THE LOADS BEING HOISTED. THESE ASSEMBLY INSTRUCTIONS WILL REQUIRE SAFE LIFTING DEVICES UP TO 1,000 LBS. SPECIFIC LOAD RATINGS FOR INDIVIDUAL LOADS WILL BE GIVEN AT THE APPROPRIATE TIME IN THE INSTRUCTIONS.

---

- MOVING OR ROTATING COMPONENTS CAN CAUSE SERIOUS INJURY OR DEATH. ALWAYS DISCONNECT POWER SOURCE BEFORE SERVICING. ENSURE SERVICE COVERS, CHAIN/BELT COVERS AND CLEAN-OUT DOOR(S) ARE IN PLACE AND SECURELY FASTENED BEFORE OPERATING MACHINE.

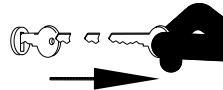




## Auger System (continued)

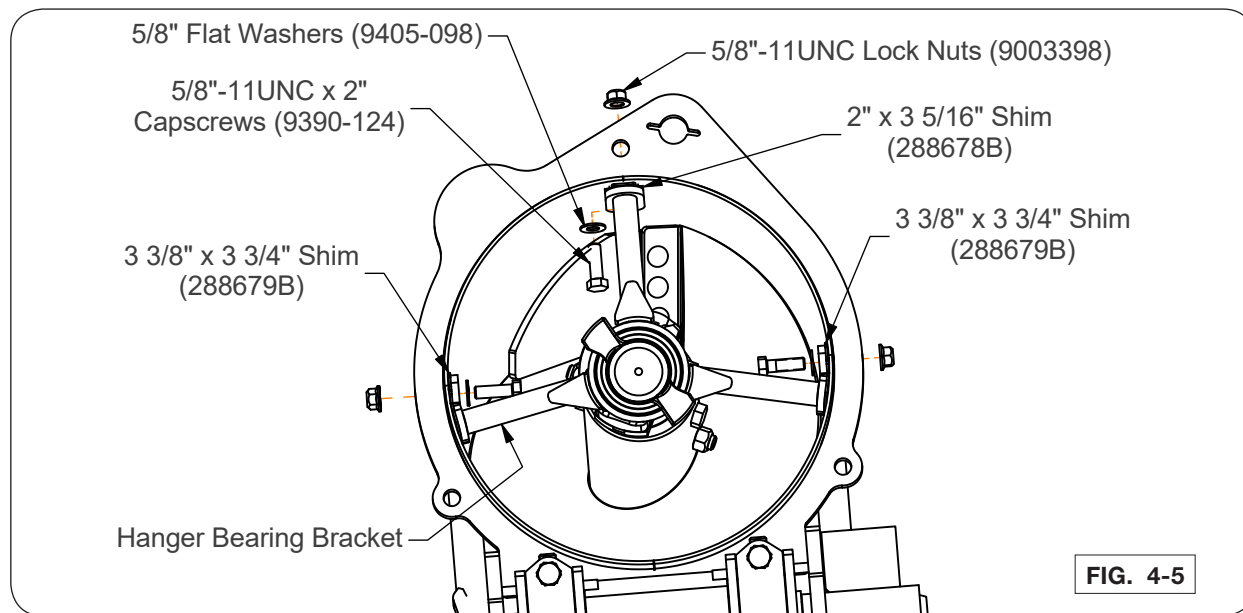
### Lower Auger

1. Hitch cart to tractor. Fully open auger flow door. Fold auger to transport position. Park the empty grain cart on a firm, level surface. Set the tractor's parking brake, shut-off the engine and remove the ignition key. Block the machine to keep it from moving.



### Lower Auger Removal

2. Remove the three 5/8"-11UNC x 2" capscrews (9390-124), 5/8" flat washers (9405-098), 5/8"-11UNC lock nuts (9003398) and shims that secure the hanger bearing bracket to the auger tube. (Fig. 4-5)
3. Using a safe lifting device rated at a minimum of 1000 lbs., support the lower auger. Remove the hanger bearing assembly. Then remove the lower auger through the auger hinge opening.



**Auger System (continued)**

**Lower Auger Assembly**

4. The replacement auger flighting is factory balanced. Remove entire auger from shipping crate and secure from rolling. The lower auger assembly is pictured in figure 4-6 for reference.

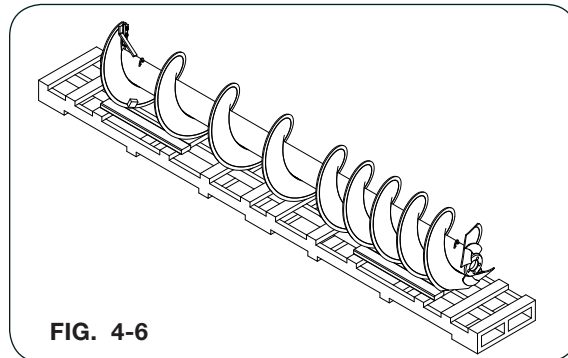


FIG. 4-6

5. Attach the u-joint assembly to the lower auger flighting by placing 3/4"-10UNC x 7" capscrews (9390-159) and 3/4"-10UNC lock nuts (9802) into the auger from opposite directions. (Fig. 4-7)

**NOTE:** If removing flighting extension hardware, replace with new hardware. Do not reuse old flighting extension hardware.

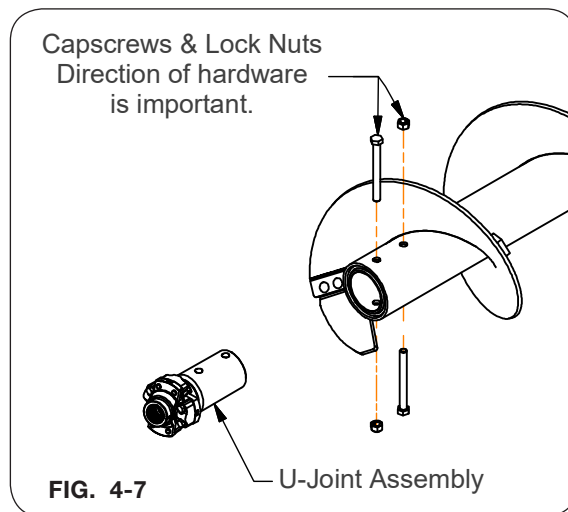


FIG. 4-7

6. Using a safe lifting device rated at a minimum of 1000 lbs., lift the auger into position. Slowly lower the auger flighting down through the auger hinge opening to intersect with the five pin drive bushing.
7. Align auger end with the five pin drive bushing and securely engage together. (Fig. 4-8)

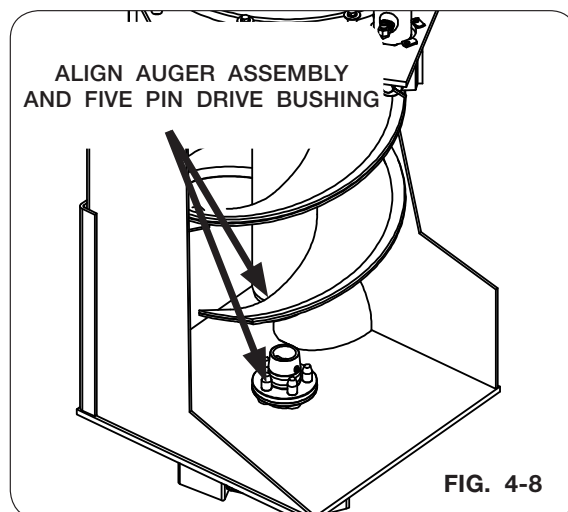
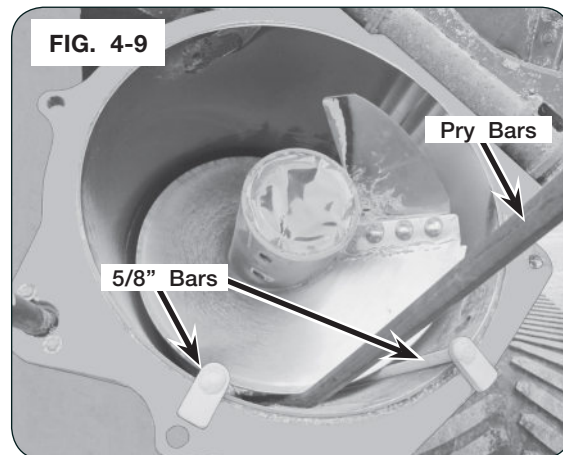


FIG. 4-8

## Auger System (continued)

### Hanger Bearing Centering

- Once the lower auger is inserted into the auger tube, center the lower auger in the tube and support with two 5/8" thick bars/wedges near the auger hinge plate. (Fig. 4-9)

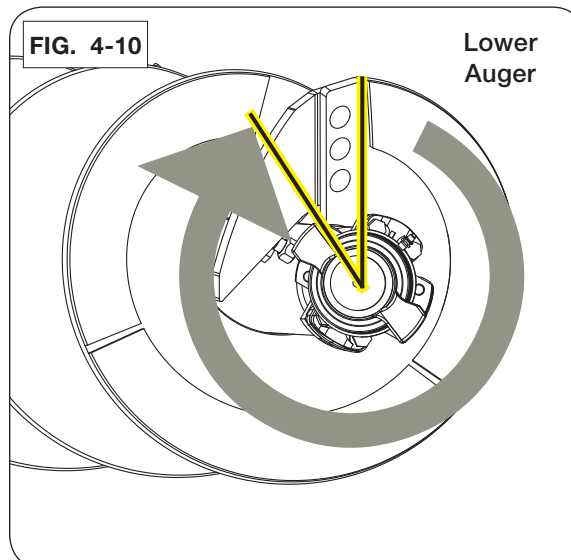


### Lower Auger Timing

- Apply anti-seize to the splines before sliding the drive dog through the hanger bearing and into the u-joint. Time the drive dog (Fig. 4-10) with the finished edge of the flighting at 12:00 o'clock. Position the drive dog at 11:00 o'clock. then install the hanger bearing.

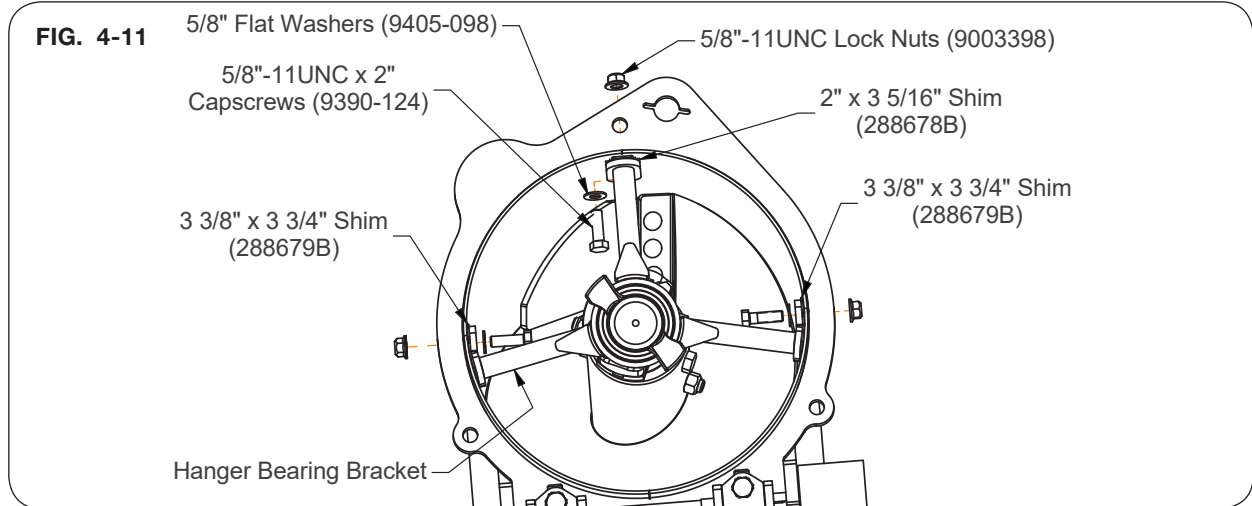
**NOTE:** When looking down at the lower flighting (Fig. 4-10) the auger rotation will be clockwise.

**NOTE:** For additional auger timing assistance, refer to your dealer for a timing fixture kit (288932Y).



### Auger System (continued)

- Loosely secure the hanger bearing using one 3" x 3 9/16" left-hand shim (288679B), one 3" x 3 9/16" right-hand shim (288679B), three 5/8"-11UNC x 2" capscrews (9390-124), three 5/8" flat washers (9405-098), and three 5/8"-11UNC lock nuts (9003398). (Fig. 4-11)

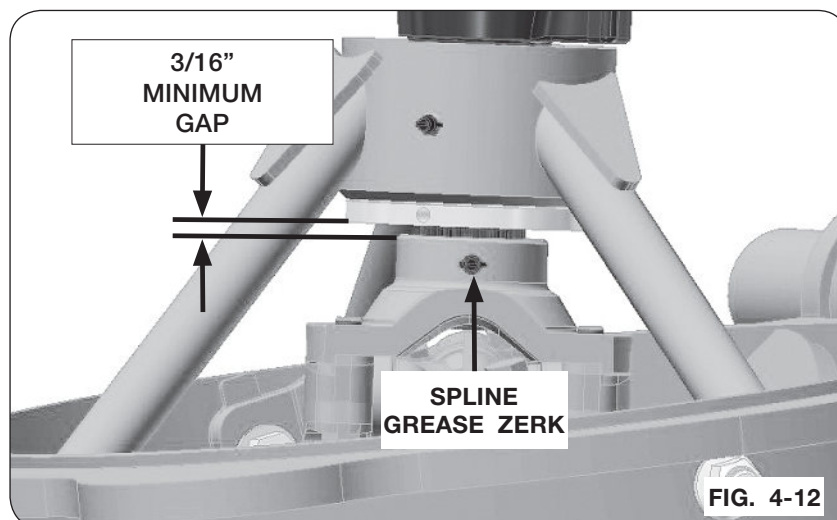


### U-Joint Spline Gap

- Verify spline gap before tightening hanger bearing hardware. Spline gap should be a minimum of 3/16". Using a lifting device rated for 250 pounds, raise the hanger bearing in the holes so the proper minimum spline gap is achieved. (Fig. 4-12)

**NOTE:** When auger components have been replaced or serviced, proper spline gap **MUST** be verified. It may be necessary to loosen the hanger bearing hardware and use the lifting device to achieve the proper spline gap.

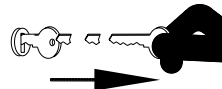
- Tighten the retaining hardware to the appropriate torque values listed in the MAINTENANCE section.
- Grease the spline and hanger bearing grease zerks. (Fig. 4-12)
- Fold upper auger to unload position and have a second user visually check for auger engagement. Test run augers at slow speed.



## Auger System (continued)

### Upper Auger

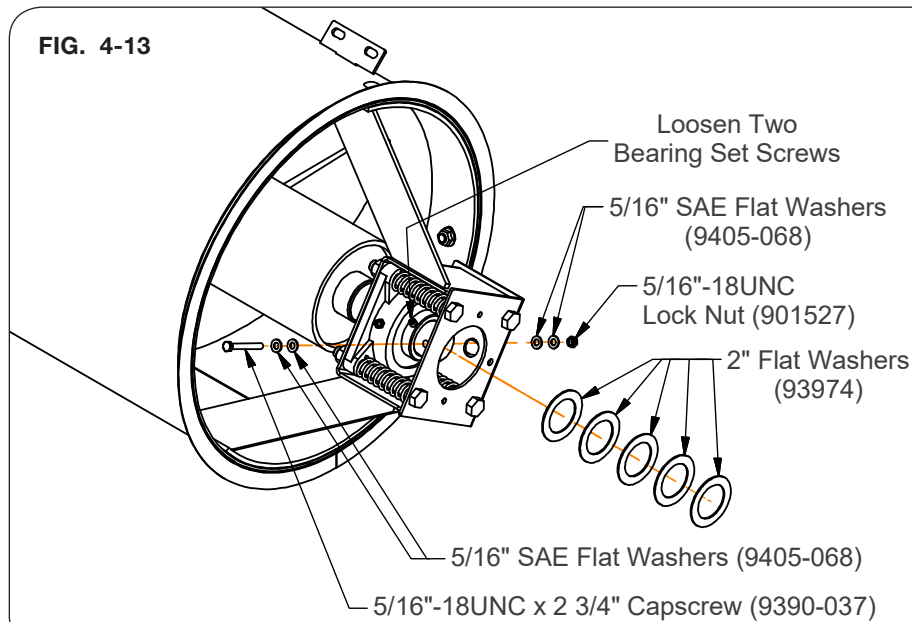
1. Hitch cart to tractor, then fold upper auger to the transport position. Park the empty grain cart on a firm, level surface. Set the tractor's parking brake, shut-off the engine and remove the ignition key. Block the machine to keep it from moving.



### Upper Auger Removal

2. Loosen the two bearing set screws. Remove and save the 5/16"-18UNC x 2 3/4" cap-screw (9390-037), four 5/16" SAE flat washers (9405-068) 5/16"-18UNC lock nut (901527) and 2" flat washers (93974). (Fig. 4-13)

FIG. 4-13



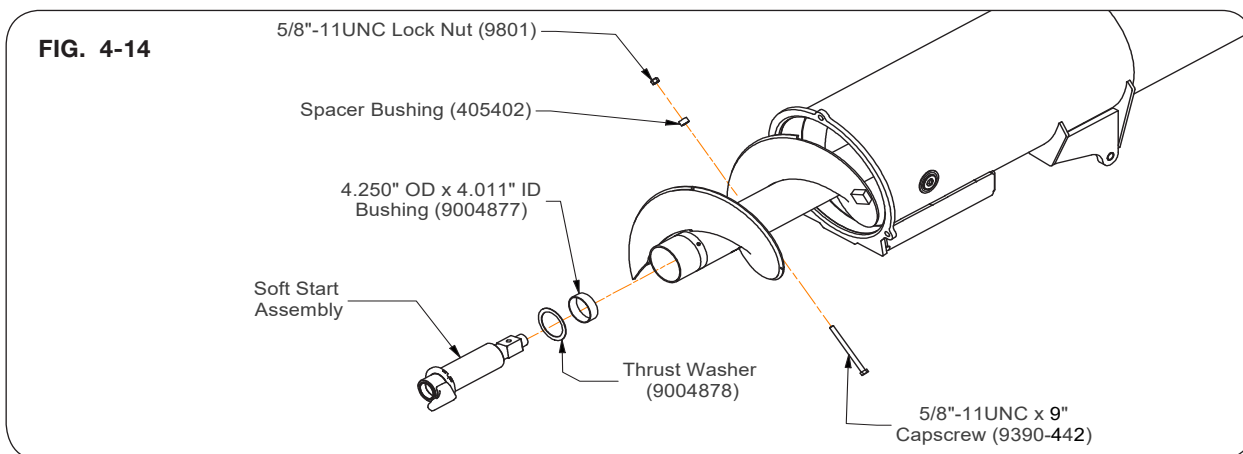
## Auger System (continued)

### Soft Start Replacement

- Use a safe lifting device rated at a minimum of 2,000 lbs. to support the upper auger, remove auger flighting from tube.
- Remove the 5/8"-11UNC x 9" capscrew (9390-442), 5/8"-11UNC lock nut (9801), soft start assembly, spacer bushing (405402), thrust washer (9004878), and bushing (9004877). Discard 5/8"-11UNC capscrew (9390-442), 5/8"-11UNC lock nut (9801), and spacer bushing (405402). (Fig. 4-14)

**NOTE:** If removing flighting extension hardware, replace with new hardware. Do not reuse old flighting extension hardware.

- Insert the bushing (9004877) into the end of the upper auger. Attach the thrust washer (9004878) and apply anti-seize to the soft start and insert into the auger tube. (Fig. 4-14)



### Upper Auger Timing

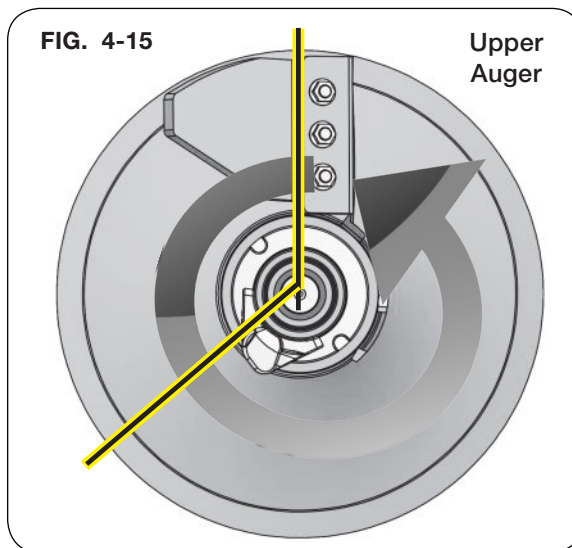
- Time the drive pin (as in Fig. 4-15) with the finished edge of the flighting at 12:00. Position the drive pin at 7:00.

**NOTE:** Looking up at the upper flighting (FIG. 18) the auger rotation will be counter clockwise.

**NOTE:** Grain leaving the lower auger flighting should be captured by the upper auger flighting within 1/2 revolution of the augers.

**NOTE:** There is only one way the soft-start will go in.

**NOTE:** For additional auger timing assistance, refer to your dealer for a timing fixture (288932Y).



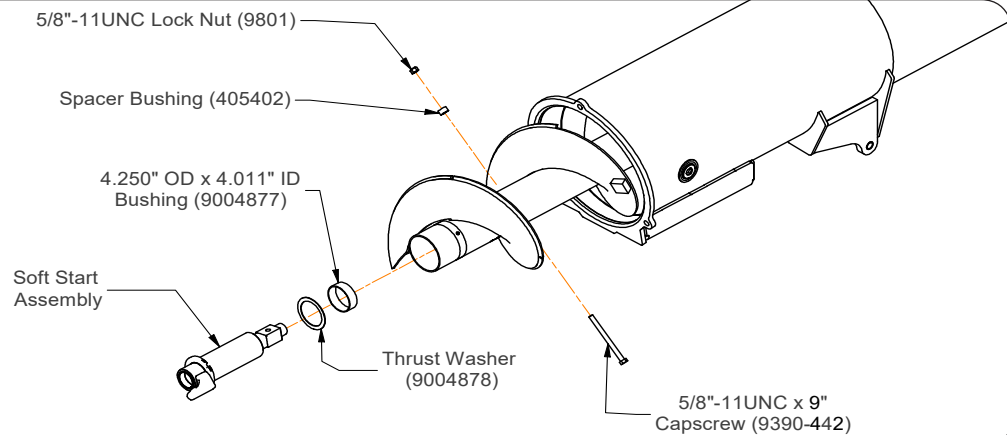
**Auger System (continued)**

**Soft Start Replacement (continued)**

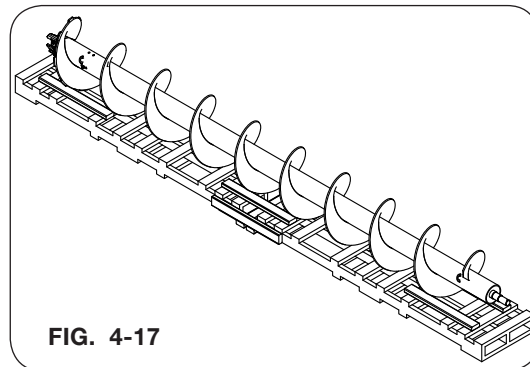
7. Insert the 5/8"-11UNC x 9" capscrew (9390-442) through auger center-tube and soft start. Place spacer bushing (405402) over threads and retain with locknut (9801). (Fig. 4-16)

**NOTE:** Verify that the spacer bushing is on the locknut side of the auger center tube.

**FIG. 4-16**



**NOTE:** The replacement auger flighting is factory balanced. Remove entire auger from shipping crate and secure from rolling. The upper auger flighting assembly is pictured in figure 4-17 for reference.



**FIG. 4-17**

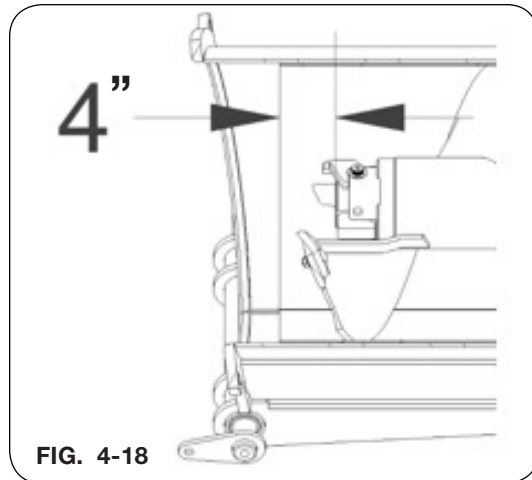
8. Using an adequate hoist and slings with a minimum capacity of 2,000 lbs. to support the upper auger, install upper auger flighting into the tube and through top flange bearing.



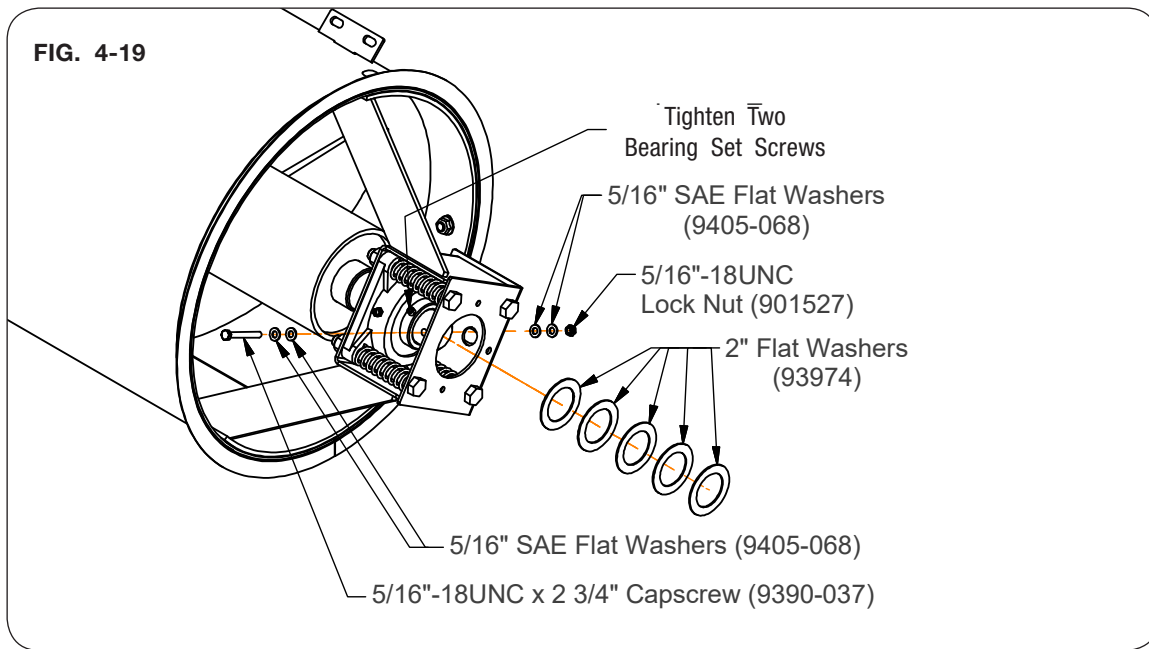
**Auger System (continued)**

**Upper Auger Height**

- Set upper auger in-set of 4". With the upper auger in the folded/transport, ensure the face of the soft start bushing that sits on the top of the drive dog should be 4" back from the square cut face of the auger housing tube. (Fig. 4-18)



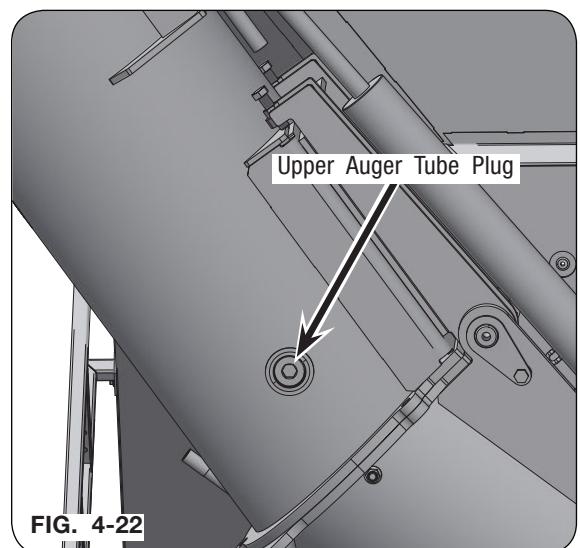
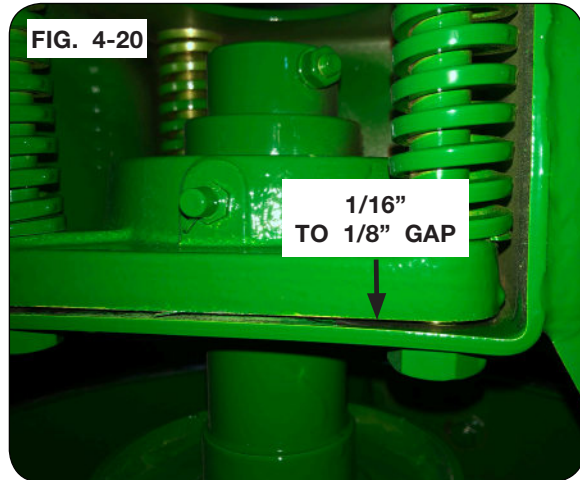
- Make sure the 4 bolt flange bearing is sitting tightly against the mounting plate and then tighten the two bearing set screws. Attach the upper auger with the 5/16"-18UNC x 2 3/4" crossbolt (9390-037), four 5/16" SAE flat washers (9405-068) 5/16"-18UNC lock nut (901527) and as many 2" flat washers (93974) as required to fill the gap between the bearing and the cross bolt. (Fig. 4-19)



**Auger System (continued)**

**Upper Auger Bearing Gap**



11. Engage PTO and test run augers to ensure drive dogs are engaged. Stop PTO, shut off tractor and remove key.
12. Verify the upper auger bearing height by inspecting the upper auger bearing in operating position. There must be a minimum 1/16" to 1/8" gap between the bearing and mount plate with the upper auger in operating position and the drive dog completely engaged. (Fig. 4-20) If gap is present, no action is needed, proceed to next step. If no gap or gap is too large, Re-adjust the upper auger placement to achieve a 1/16-1/8" gap. If there is no gap, the upper auger will need to be moved ahead. If there is too large of a gap, move it backwards in the upper auger housing. The number of washers (93974) will also need to be adjusted to eliminate any gap between the bearing and the cross bolt. (Fig. 4-21)
13. Place upper auger in the folded/transport position.
14. Once the upper auger height has been verified, remove the upper bearing set screws one at a time, and dimple the stud shaft with a 1/4" diameter drill bit. Apply TL-42 blue thread locker to the set screws, and reinstall the set screws into the flange bearing and into the dimples on the stud shaft. Tighten set screws. Tighten all hardware.
15. Remove upper auger tube plug and visually verify upper and lower auger engagement. (Fig. 4-22)
17. If upper and lower auger engagement is good, install upper auger tube plug
18. Test run auger driveline to verify smooth driveline operation. Check for noise and/or vibration and address immediately.



## Auger System (continued)

### Auger Flow Door Cylinder Replacement

#### **WARNING**

- TO PREVENT PERSONAL INJURY OR DEATH, ALWAYS ENSURE THAT THERE ARE PEOPLE WHO REMAIN OUTSIDE THE CART TO ASSIST THE PERSON WORKING INSIDE, AND THAT ALL SAFE WORKPLACE PRACTICES ARE FOLLOWED. THERE IS RESTRICTED MOBILITY AND LIMITED EXIT PATHS WHEN WORKING INSIDE THE IMPLEMENT.
- NEVER ENTER CART WITH AUGER OR TRACTOR RUNNING. SERIOUS OR FATAL INJURY CAN OCCUR DUE TO ENTANGLEMENT WITH ROTATING COMPONENTS. ALWAYS STOP ENGINE AND REMOVE KEY BEFORE ENTERING CART.
- EYE PROTECTION AND OTHER APPROPRIATE PERSONAL PROTECTIVE EQUIPMENT MUST BE WORN WHILE SERVICING IMPLEMENT.
- KEEP HANDS CLEAR OF PINCH POINT AREAS. 
- RELIEVE THE HYDRAULIC SYSTEM OF ALL PRESSURE BEFORE ADJUSTING OR SERVICING. SEE THE HYDRAULIC POWER UNIT OPERATOR'S MANUAL FOR PROPER PROCEDURES.
- HIGH-PRESSURE FLUIDS CAN PENETRATE THE SKIN AND CAUSE SERIOUS INJURY OR DEATH. LEAKS OF HIGH-PRESSURE FLUIDS MAY NOT BE VISIBLE. USE CARDBOARD OR WOOD TO DETECT LEAKS IN THE HYDRAULIC SYSTEM. SEEK MEDICAL TREATMENT IMMEDIATELY IF INJURED BY HIGH-PRESSURE FLUIDS. 
- HYDRAULIC SYSTEM MUST BE PURGED OF AIR BEFORE OPERATING TO PREVENT SERIOUS INJURY OR DEATH.
- FALLING OBJECTS CAN CAUSE SERIOUS INJURY OR DEATH. DO NOT WORK UNDER THE MACHINE AT ANY TIME WHILE BEING HOISTED. BE SURE ALL LIFTING DEVICES AND SUPPORTS ARE RATED FOR THE LOADS BEING HOISTED. THESE ASSEMBLY INSTRUCTIONS WILL REQUIRE SAFE LIFTING DEVICES UP TO 5000 LBS. SPECIFIC LOAD RATINGS FOR INDIVIDUAL LOADS WILL BE GIVEN AT THE APPROPRIATE TIME IN THE INSTRUCTIONS.

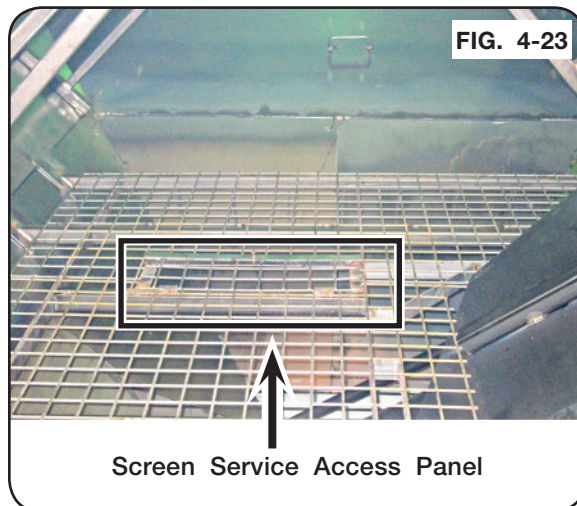
1. Park the empty grain cart on a firm, level surface and extend auger. Block the machine to keep it from moving. Unfold upper auger to make the flow door cylinder easier to access. Close the flow door, relieve hydraulic pressure, see tractor operator's manual. Set the tractor's parking brake, shut-off the engine, remove the ignition key and disconnect the PTO shaft.



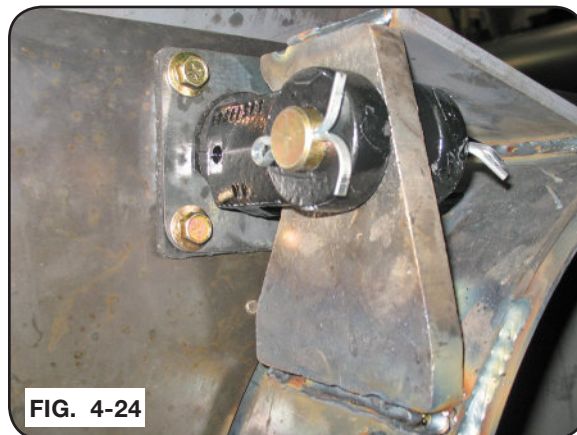
**Auger System** (continued)

**Auger Flow Door Cylinder Replacement** (continued)

2. On the inside of the cart, open the screen service access panel. (Fig. 4-23)



3. Remove the cotter pins from the lower cylinder pin then remove the pin. Then remove the four 3/8"-16UNC x 1" flange bolts holding on the gasket and gasket plate. (Fig. 4-24)



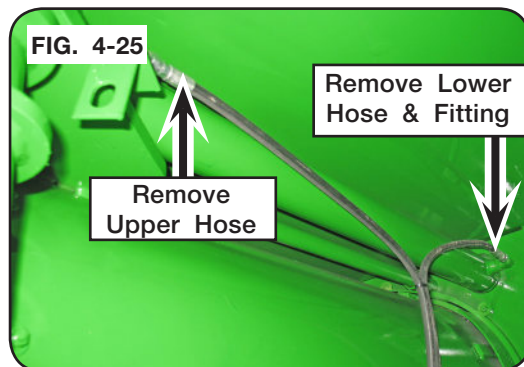
4. Remove all tools and extra hardware from the grain cart. Make sure all personnel are outside of the hopper. Then, retract the cylinder so that there is about 8" of clearance between the cylinder clevis and the lug.
5. Relieve hydraulic pressure, shut off the engine, remove the ignition key, and disconnect the hydraulic hoses from the tractor and cart.



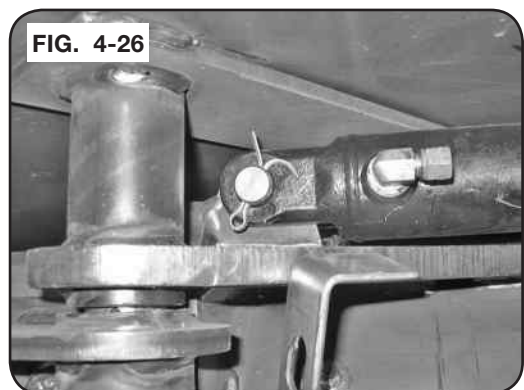
**Auger System (continued)**

**Auger Flow Door Cylinder Replacement (continued)**

6. Label the hydraulic hoses to indicate upper and lower. Disconnect them from the cylinder, along with the lower hydraulic fitting. (Fig. 4-25)



7. Remove the cotter pins from the upper cylinder pin and remove pin. (Fig. 4-26)



8. Slide the flow door cylinder through the hole in the junction box until the upper cylinder clevis clears the lug, then raise the top of the cylinder above the auger fold bushing. Using a safe lifting device rated for 200 lbs. remove the cylinder.
9. Replace with the new cylinder and insert the upper cylinder pin. Remove the cylinder port plugs. Manually extend the cylinder until the lower clevis lines up with the door lug and assemble the pin and cotter pins. Assemble hydraulic fittings and attach hoses.
10. Replace rubber gasket and gasket plate with 3/8"-16UNC x 1" flange screws, shut and secure the screen service access panel.
11. Remove all tools and extra hardware from the grain cart. Make sure all personnel are outside of the hopper. After the hydraulic components have been tightened, purge air from system as follows:
  - A. Clear all personnel and objects from the area, including where the machine will have full range of motion during the hydraulic movement. Remove transport locks from the machine.
  - B. Pressurize the system and maintain the system at full pressure for at least 5 seconds after the cylinder rods stop moving, or hydraulic motors have completed the required movement. Check that all movements are fully completed.
  - C. Check oil reservoir in the hydraulic power source and refill as needed.
  - D. Pressurize the system again to reverse the motion of step B. Maintain pressure on the system for at least 5 seconds after the cylinder rods stop moving, or hydraulic motors have completed the required movement. Check that all movements are fully completed.
  - E. Check for hydraulic oil leaks using cardboard or wood. Tighten connections according to directions in the Torque Specifications in the MAINTENANCE section.
  - F. Repeat steps in B, C, D, and E 10-12 times.



## Auger System (continued)

### Auger Floor Door Cylinder Stop

**⚠ DANGER**

- ELECTROCUTION WILL CAUSE SERIOUS INJURY OR DEATH. ELECTROCUTION CAN OCCUR WITHOUT DIRECT CONTACT. KEEP AWAY FROM ALL ELECTRICAL LINES AND DEVICES.



- ENTANGLEMENT WITH THE DRIVELINE WILL CAUSE SERIOUS INJURY OR DEATH. KEEP ALL GUARDS AND SHIELDS IN GOOD CONDITION AND PROPERLY INSTALLED AT ALL TIMES. AVOID PERSONAL ATTIRE SUCH AS LOOSE FITTING CLOTHING, SHOE STRINGS, DRAWSTRINGS, PANTS CUFFS, LONG HAIR, ETC. THAT CAN BECOME EN-TANGLED IN A ROTATING DRIVELINE.

1. Before loading cart or operating auger, verify that the flow control door is closed.
2. Choose an area free from obstructions and unfold auger into unloading position. Allow sufficient time for the cylinder to fully engage the two augers.

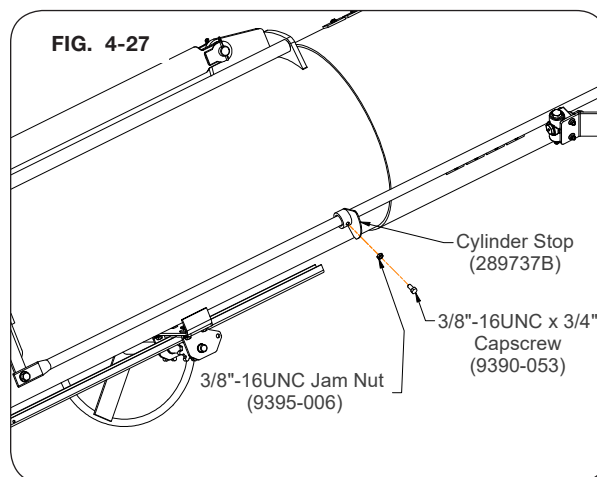
3. Locate the cylinder stop on the flow door indicator rod. (Fig. 4-27)

4. Loosen the capscrew and jam nut retaining the cylinder stop.

**NOTE:** Ensure the cylinder stop is centered on the flow control valve plunger and will not contact hoses during movement of the flow door.




5. Move the cylinder stop along the indicator rod to desired flow door opening setting, and tighten retaining screw and jam nut.

**NOTE:** In order to increase grain flow to the maximum bushels per minute, cylinder stop (289737B) can be adjusted further down on the indicator rod. (Fig. 4-27)



## Auger Driveline

### **WARNING**

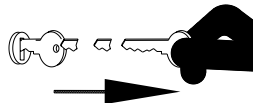
- EYE PROTECTION AND OTHER APPROPRIATE PERSONAL PROTECTIVE EQUIPMENT MUST BE WORN WHILE SERVICING IMPLEMENT. 
- TIPPING OR MOVEMENT OF THE MACHINE CAN CAUSE SERIOUS INJURY OR DEATH. BE SURE MACHINE IS SECURELY BLOCKED.
- KEEP HANDS CLEAR OF PINCH POINT AREAS. 
- MOVING OR ROTATING COMPONENTS CAN CAUSE SERIOUS INJURY OR DEATH. ALWAYS DISCONNECT POWER SOURCE BEFORE SERVICING. ENSURE SERVICE COVERS, CHAIN/BELT COVERS AND CLEAN-OUT DOOR(S) ARE IN PLACE AND SECURELY FASTENED BEFORE OPERATING MACHINE. 
- FALLING OBJECTS CAN CAUSE SERIOUS INJURY OR DEATH. DO NOT WORK UNDER THE MACHINE AT ANY TIME WHILE BEING HOISTED. BE SURE ALL LIFTING DEVICES AND SUPPORTS ARE RATED FOR THE LOADS BEING HOISTED. THESE ASSEMBLY INSTRUCTIONS WILL REQUIRE SAFE LIFTING DEVICES UP TO 2000 LBS. SPECIFIC LOAD RATINGS FOR INDIVIDUAL LOADS WILL BE GIVEN AT THE APPROPRIATE TIME IN THE INSTRUCTIONS.



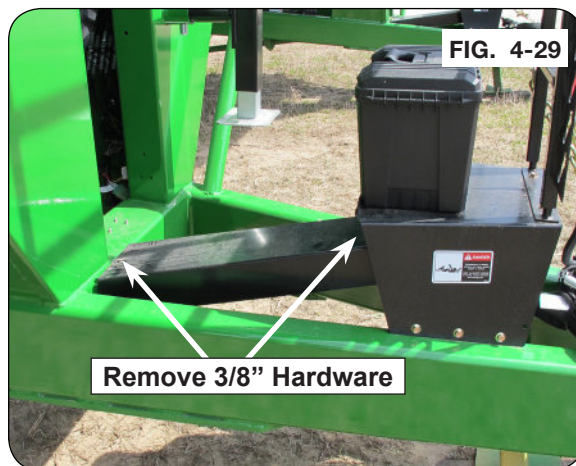
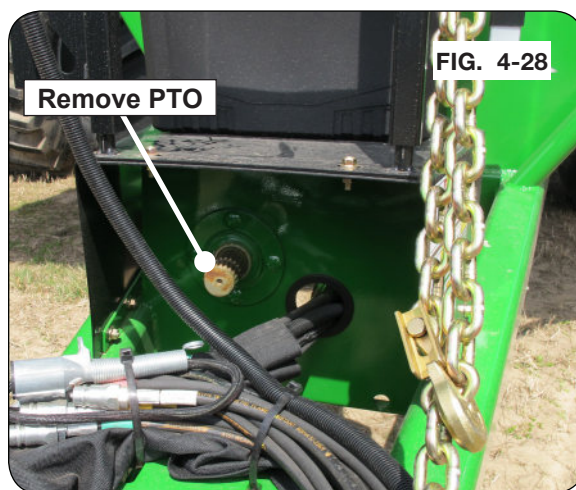
## Auger Driveline

### Disassembly

1. Park the empty unit on a firm, level surface. Block the machine to keep it from moving. Set the tractor parking brake, shut off the engine, and remove the ignition key from the tractor before disconnecting driveline assembly and bearing hardware. Completely disconnect the unit from the towing vehicle.
2. Remove the PTO from the driveshaft. (Fig. 4-28) See PTO Driveline - Uncoupling in this section.

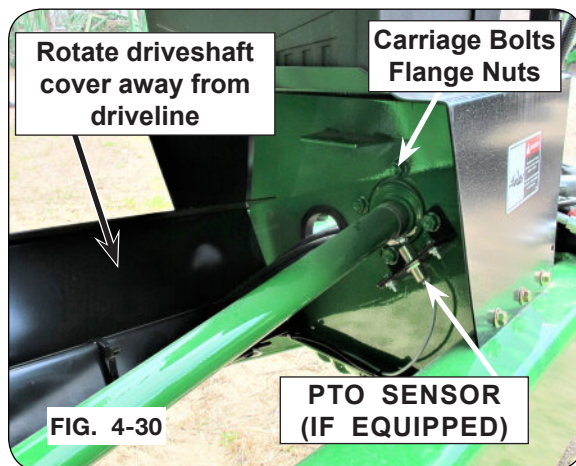


3. Remove 3/8" hardware from the hitch driveshaft cover. Rotate the hitch driveshaft cover, electrical routing and hydraulic lines away from the driveline. Keep the 3/8" hardware. (Fig. 4-29 & 4-30)



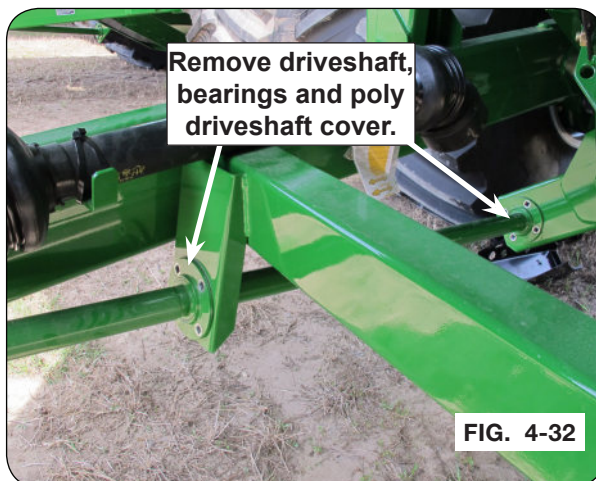
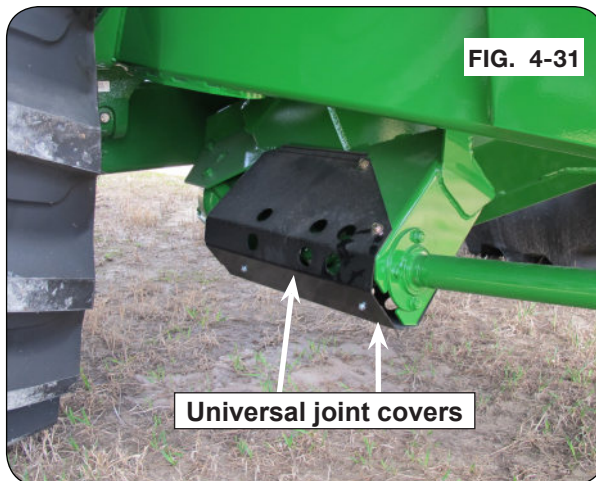
4. Loosen the 5/16" set screws from the 4 original flangette bearings (9005061).
5. Remove the 1/2" carriage bolts and flange nuts retaining the front flangette bearing. Discard 1/2" hardware. (Fig. 4-30)

**NOTE:** If a PTO sensor is installed on this grain cart, remove it from the front flangette bearing.



### Auger Driveline (continued)

6. Remove universal joint covers from the driveshaft. Keep hardware and universal joint covers. (Fig. 4-31)
7. Remove driveshaft lock collars (if lock collars are attached to driveshaft).
8. Remove the 3 rear original bearings and 1/2" carriage bolts and flange nuts retaining the 3 flangette bearings from the grain cart. Discard the 3 bearings and 1/2" hardware. (Fig. 4-32)
9. Mark front and rear positions of driveline covers.
10. Slide driveshaft forward until the rear spline is out of the universal joint connected to the gearbox. Discard rear poly driveshaft cover. (Fig. 4-32)
11. Drop the gearbox end of driveshaft down and slide driveshaft out of the flangette bearing on the hitch end of the driveshaft.

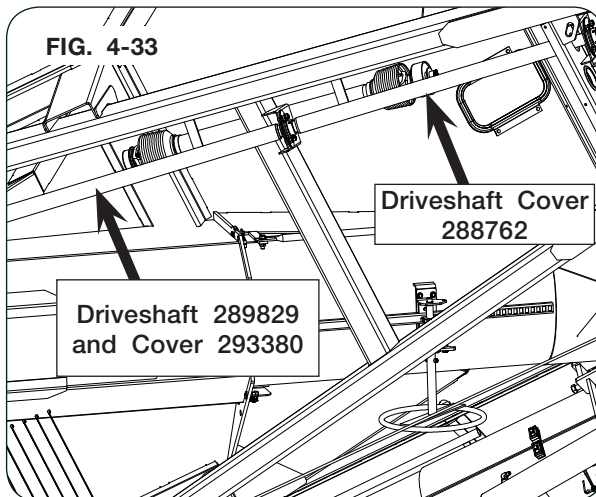


### Reassembly

**NOTE:** Before reassembly, put a line on the dimples of the driveshaft to make dimples easier to locate when assembling.

**NOTE:** Ends of the driveshaft are symmetrical.

12. Attach new 1 3/4" dia. two-piece lock collars (9008674) to both sides of new bearing (9005061) closest to the U-Joint, when installing bearing onto new 144 5/8" driveshaft (289819).
13. When installing 3 new bearings (9005061) onto new driveshaft (289819), assemble 52" PVC driveshaft cover (293380) between bearings near the gearbox, and 41 1/2" PVC driveshaft cover (288762) between bearings behind the hitch driveline cover. Install flange bearings (9005061) on the driveshaft with the lock collars forward. (Fig. 4-33)
14. Slide the hitch end of the driveshaft assembly into the bearing near hitch of the cart. Attach the flangette bearing using new 1/2" carriage bolts (9388-104) and new flange nuts (91267) into the bracket mount. Loosely tighten the hardware on the bearing. (Fig. 4-32)



**Auger Driveline (continued)**

15. Lift the driveshaft into the rear mounting bracket. Attach the flangette bearings to the mounting brackets using new 1/2" hardware. Tighten all flangette bearing hardware, but do not tighten lock collars at this time. (Fig. 4-34 & 4-35)

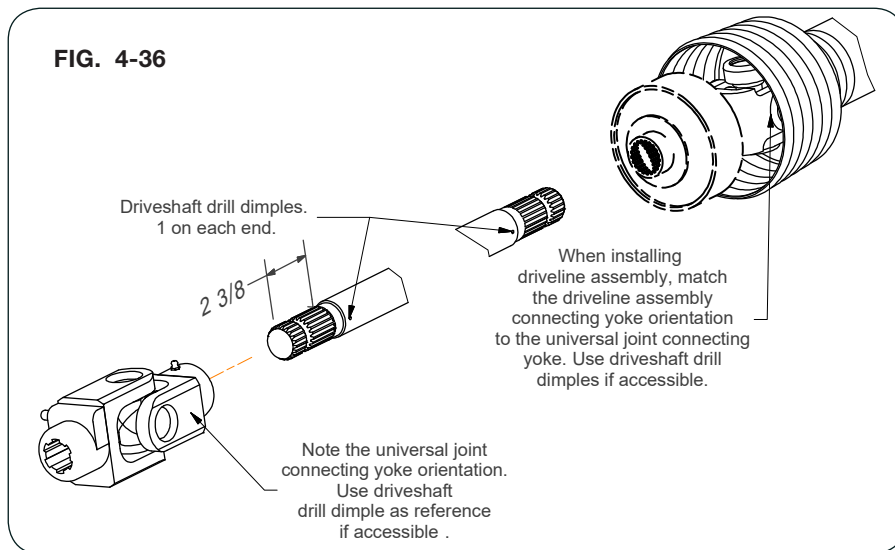
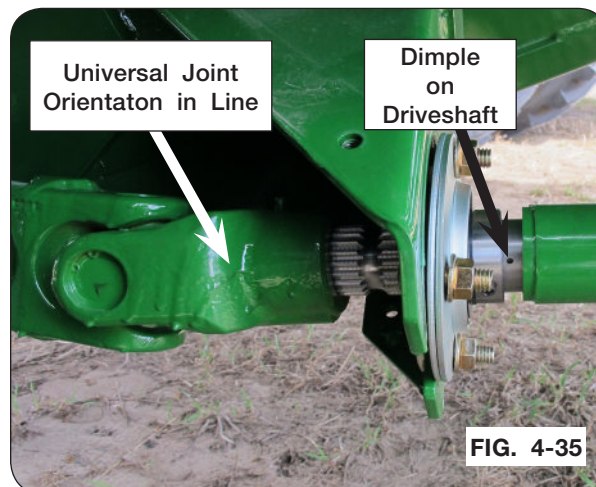
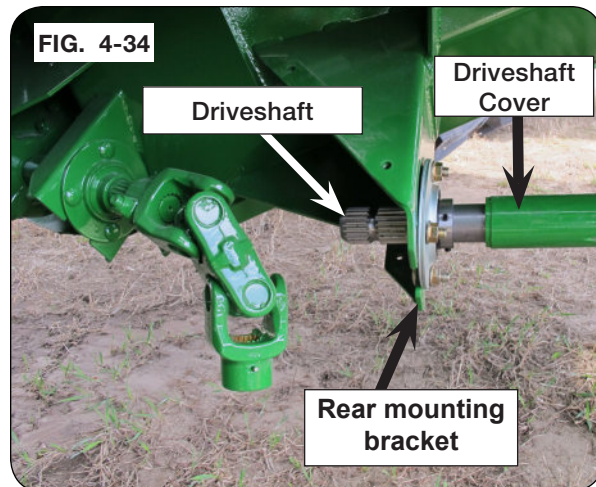
16. Align driveshaft dimple with u-joint (See Fig. 4-34 and 4-35)

17. Slide the driveshaft into the universal joint until the end of the shaft extends into the universal joint about 2 3/8". Ensure universal joint and driveshaft splines completely engage. Verify the hitch end has adequate length for driveline assembly to connect. (Fig. 4-34 & 4-35)

18. Remove the 5/16" setscrews from the lock collars on the bearings. Drill one setscrew recess on both ends of the driveshaft by going through the setscrew threaded hole and recess the driveshaft being careful to not damage threads. Drill the recess to a depth that setscrews are flush with the bearing. (Fig. 4-34)

19. Apply thread locker on bearing setscrews. Reinstall setscrews to lock collars on bearings and tighten.

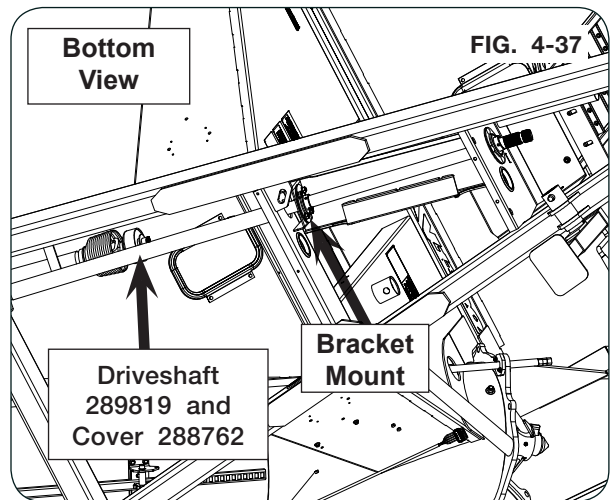
20. Torque lock collars to 325 inch-lbs., if lock collars are attached to driveshaft.





### Auger Driveline (continued)

21. Install new flangette bearing (9005061) onto the front bracket mount under the right-hand standard with the lock collar on the front side of the bracket mount toward the PTO. Insert four new 1/2" carriage bolts (9388-104) and (91267) flange nuts into the bracket mount. Loosely tighten the hardware on the bearing. (Fig. 4-37)

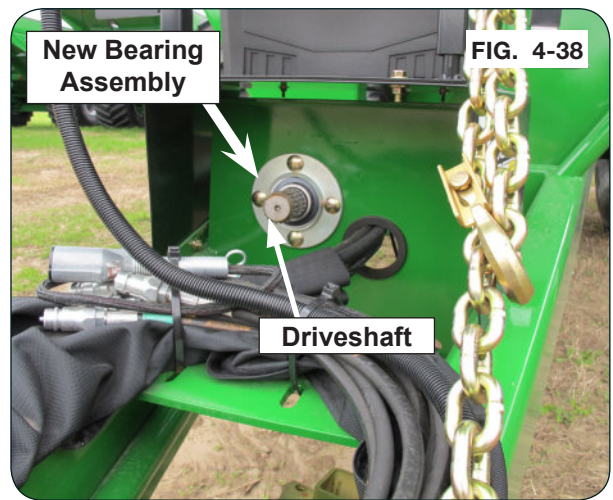


22. Remove existing front flangette bearing and install new flangette bearing (9005061) onto the front support under the ladder with the lock collar toward the PTO. Insert four new 1/2" carriage bolts (9388-104) and four new flange nuts (91267) into the bearing. Loosely tighten the hardware on the bearing. (Fig. 4-38)

**NOTE:** If a PTO sensor is installed on this grain cart, install it onto the front flange bearing.

23. Torque the 1/2" hardware on the 4 new bearings to 62-68 ft. lbs.

(continued on next page)



**Auger Driveline (continued)**

24. For alignment of the yoke, the orientation of the universal joint at the gearbox must be in line with the driveshaft drill dimple when the driveline assembly is attached. Use the driveshaft dimple for reference, if accessible. (Fig. 4-39)

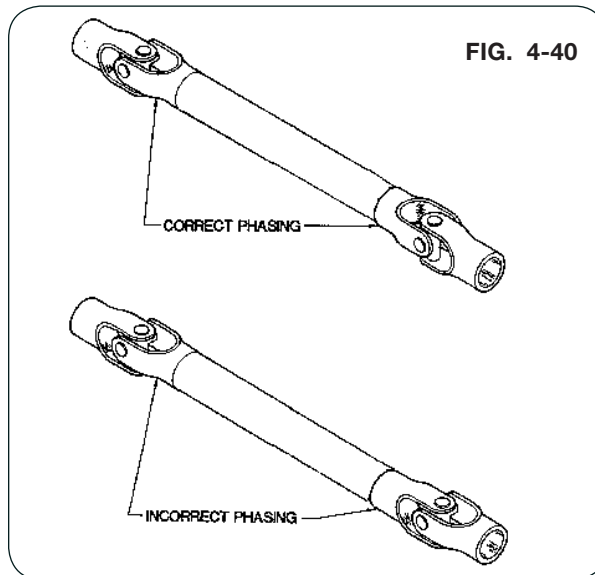
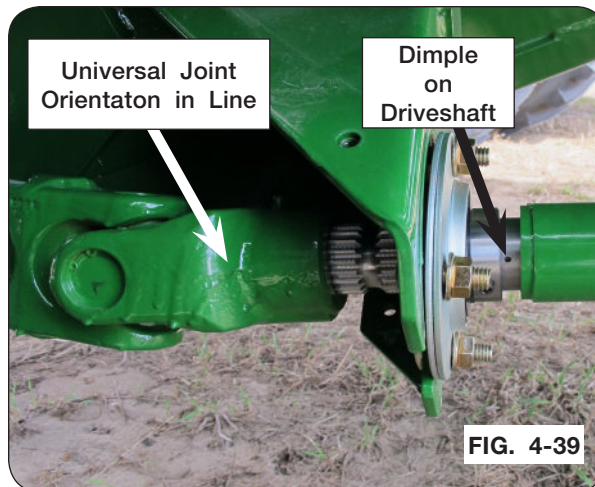
25. Align the PTO yoke with the front driveshaft dimple and install the PTO into the driveshaft. (Fig. 4-40)

**NOTE:** Check/fill gearbox oil and grease universal joints before installing universal joint covers.

26. Reattach original u-joint covers using original hardware from Step 6.

27. Reattach hitch driveshaft cover, located behind the ladder, using original hardware from Step 3.

28. Test run driveline. Check for smooth drive-line operation.

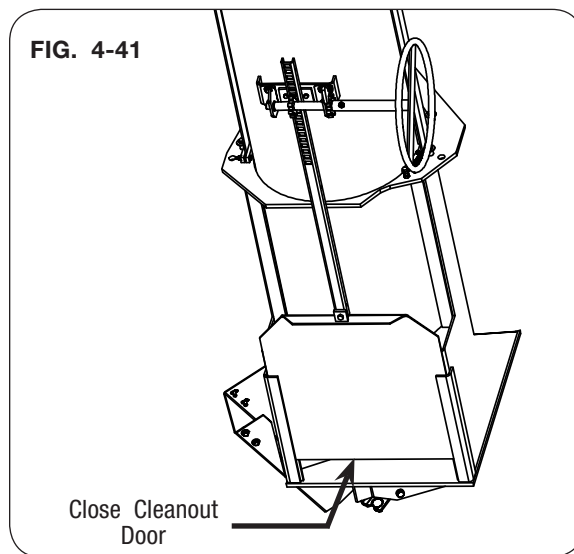


## Adjusting Cleanout Door

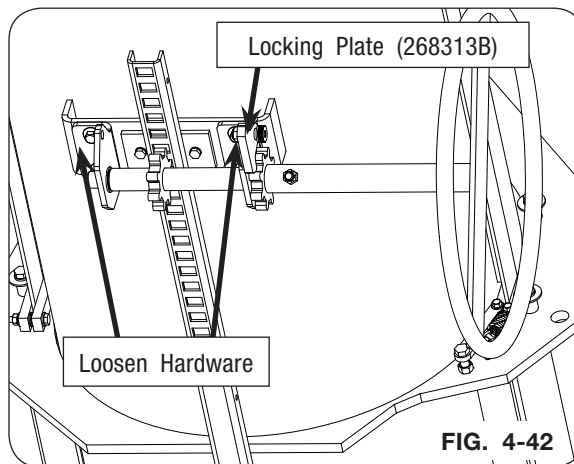
### **WARNING**

- MOVING PARTS CAN CRUSH AND CUT. KEEP AWAY FROM MOVING PARTS.
- KEEP HANDS CLEAR OF PINCH POINT AREAS.
- EYE PROTECTION AND OTHER APPROPRIATE PERSONAL PROTECTIVE EQUIPMENT MUST BE WORN WHILE SERVICING THE IMPLEMENT.

1. Park the empty grain cart on a firm and level surface. Block the machine to keep it from moving. Set the tractor's parking brake, shut-off the engine, remove the ignition key and disconnect the PTO shaft.
2. Inspect and verify that all the grain dust and filings are removed that may prevent the door from shutting completely. (Fig. 4-41)
3. Completely close cleanout door.

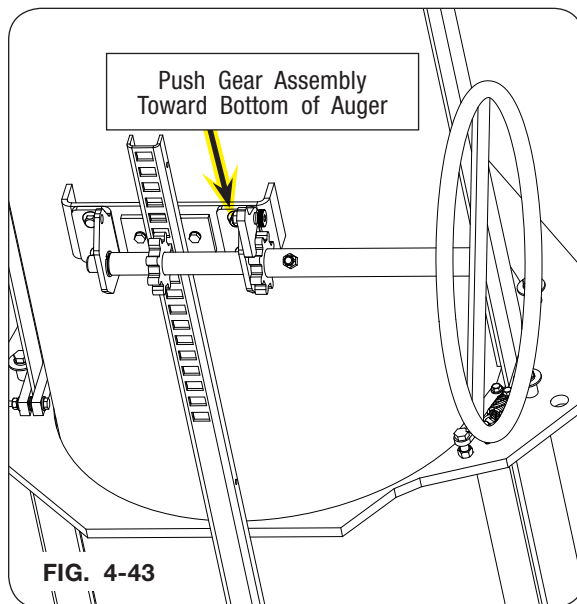


4. Engage the locking plate (268313B). (Fig. 4-42)
5. Loosen mounting hardware. (Fig. 4-42)

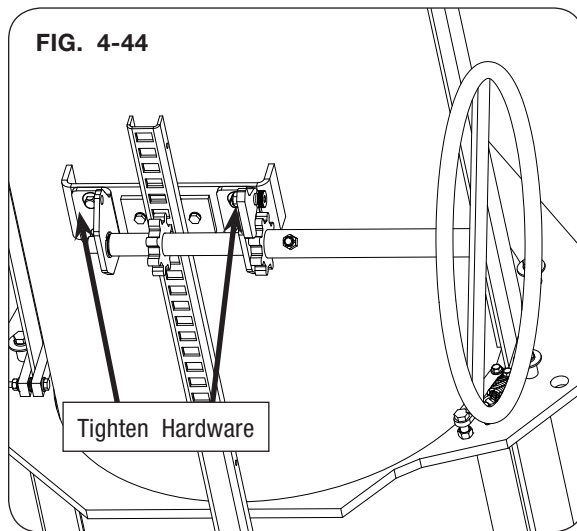


### Adjusting Cleanout Door (continued)

5. Push the gear assembly toward bottom of auger to remove excess movement and prevent the door from moving upward when unloading the cart. (Fig. 4-43)



5. Tighten hardware loosened in step 4. (Fig. 4-44)
6. Check door operation. Lock the handle weldment into position. (Fig. 4-44)





**Verify Telescoping PTO Shaft Length**

**⚠ WARNING**

- PROPERLY EXTENDED AND COLLAPSED LENGTHS OF THE TELESCOPING PTO SHAFT MUST BE VERIFIED BEFORE FIRST OPERATION WITH EACH AND EVERY DIFFERENT TRACTOR. IF THE EXTENDED LENGTH OF THE PTO SHAFT IS NOT SUFFICIENT, IT MAY BECOME UNCOUPLED IN OPERATION AND CAUSE SERIOUS INJURY OR DEATH FROM CONTACT WITH UNCONTROLLED FLAILING OF PTO SHAFT ASSEMBLY COMPONENTS.

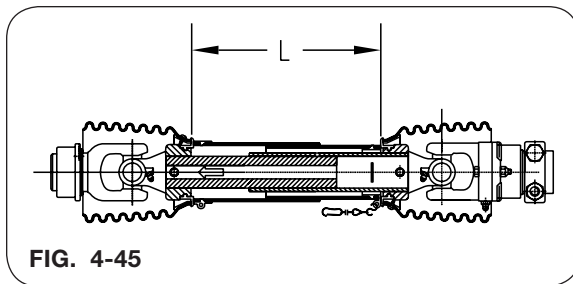
An excessive collapsed length can result in damage to the PTO driveline and attached components. This is most likely to occur during extreme turning angles and/or travel over rough terrain. Conditions are amplified on tractors with tracks operating in uneven terrain, particularly rice levies. Damaged driveline components can result in unsafe operation and severely reduced driveline component life.

**NOTE:** Do not exceed 10 degrees beyond a straight pull line while operating the PTO.

To verify proper extended and collapsed lengths, use the following procedure:

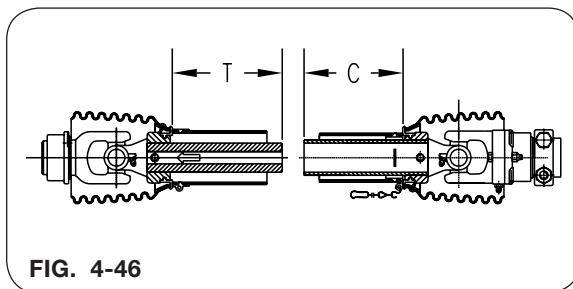
1. Fully collapse PTO shaft and measure length "L" (Fig. 4-45).

Enter here: \_\_\_\_\_ (1)  
 (Verify that outer tube does not bottom out on surrounding plastic shield components).



2. Pull apart PTO telescoping shaft ends and measure lengths "T" & "C" (Fig. 4-46).

Add "T" & "C" measurements together  
 Enter total here: \_\_\_\_\_ (2)



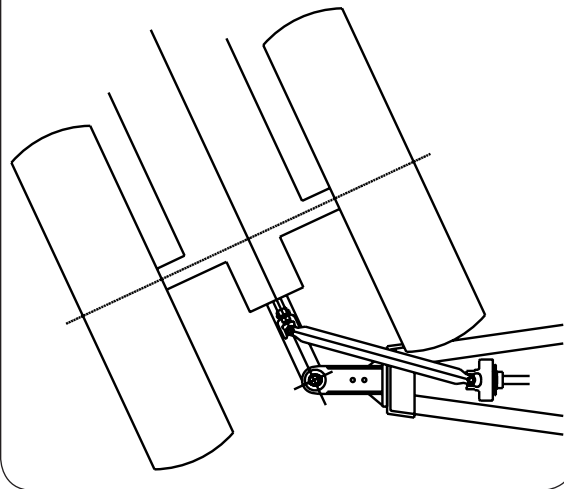
3. Calculate maximum recommended extended length:
  - a. Subtract line 1 from line 2. Enter here: \_\_\_\_\_ (a)
  - b. Divide line (a) by 2. Enter here: \_\_\_\_\_ (b)
  - c. Add line (b) to line 1. Enter here: \_\_\_\_\_ (c)
  - d. Subtract 3 inches from line (c). Enter here: \_\_\_\_\_ (d)

This is the maximum recommended extended length (LB).

### Verify Telescoping PTO Shaft Length (continued)

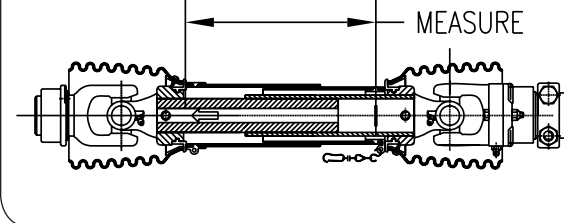
4. Hitch tractor drawbar to cart, ensuring that tractor and cart are on level ground and coupled as straight as practical.
5. Connect PTO shaft to tractor, and measure length “L” from same points as used in step 1. **Ensure that this measurement does not exceed the maximum recommended extended length calculated in step 3 above.** If necessary, choose a shorter drawbar position, or obtain a longer PTO shaft assembly or drawbar before operating cart.
6. Disconnect PTO shaft from tractor. Position the tractor to obtain tightest turning angle, relative to the cart. (Fig. 4-47)

FIG. 4-47



7. Measure length “L” from same points as used in step 1. This distance must be at least 1.5 inches greater than the distance measured in step 1. If necessary, adjust length of PTO shaft by cutting inner and outer plastic guard tubes and inner and outer sliding profiles by the same length. Round off all sharp edges and remove burrs before greasing and reassembling shaft halves. (Fig. 4-48)

FIG. 4-48



## PTO Shaft and Clutch

### Coupling the PTO driveshaft (Figs. E1 - E2)

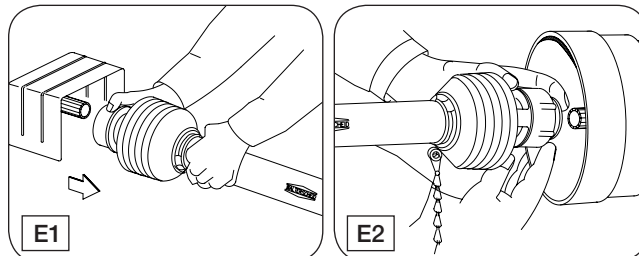
Clean and grease the PTO and implement input connection (IIC)

#### AS-Lock

1. Pull locking collar and simultaneously push PTO driveshaft onto PTO shaft until the locking device engages.

#### Push-Pull Lock

2. Pull locking collar and simultaneously push PTO driveshaft onto PTO shaft until the locking device engages.



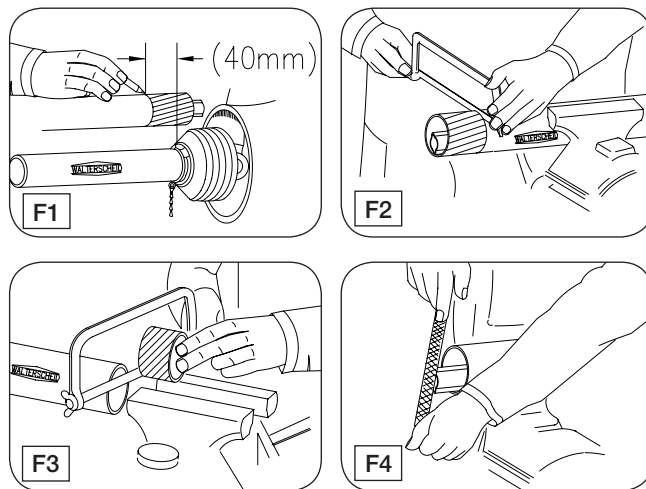
## **⚠ WARNING**

- CHECK TO ENSURE ALL THE LOCKS ARE SECURELY ENGAGED BEFORE STARTING WORK WITH THE PTO DRIVESHAFT.

### Length Adjustment (Figs. F1 - F4)

**NOTE:** Maximum operating length LB. (Refer to “Verify Telescoping PTO Shaft Length” for LB length.)

1. To adjust length, hold the half-shafts next to each other in the shortest working position and mark them.
2. Shorten inner and outer guard tubes equally.
3. Shorten inner and outer sliding profiles by the same length as the guard tubes.
4. Round off all sharp edges and remove burrs. Grease sliding profiles.



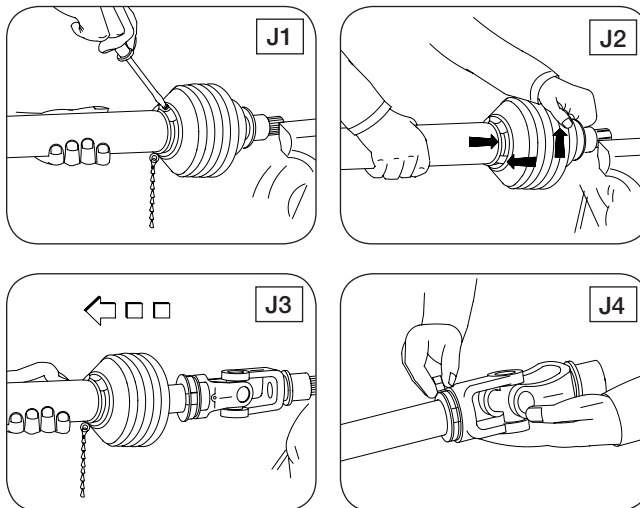
## **⚠ WARNING**

- CHECK THE LENGTH OF THE TELESCOPING MEMBERS TO ENSURE THE DRIVELINE WILL NOT BOTTOM OUT OR SEPARATE WHEN TURNING AND/OR GOING OVER ROUGH TERRAIN.

**PTO Shaft and Clutch (continued)**

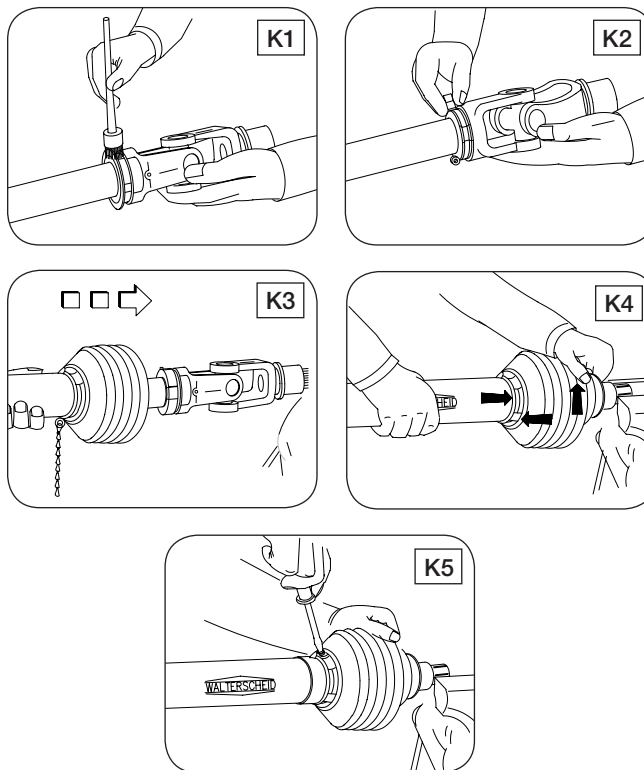
**To Dismantle Guard (Figs. J1 - J4)**

1. Remove locking screw.
2. Align bearing tabs with cone pockets.
3. Remove half-guard.
4. Remove bearing ring.



**To Assemble Guard (Figs. K1 - K5)**

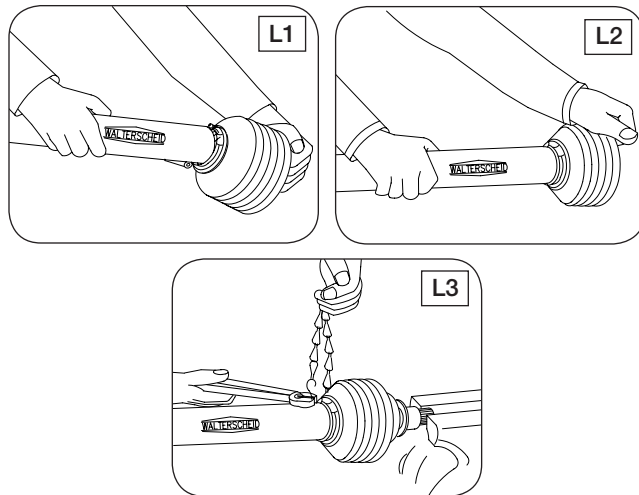
1. Grease yoke groove and inner profile tube.
2. Fit bearing ring in groove with recesses facing profile tube.
3. Slip on half-guard.
4. Turn cone until it engages correctly.
5. Install locking screw.



**PTO Shaft and Clutch (continued)**

**To Assemble Cone (Figs. L1 - L3)**

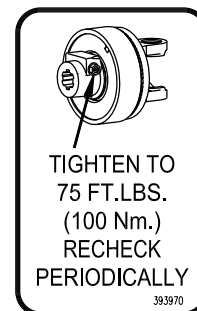
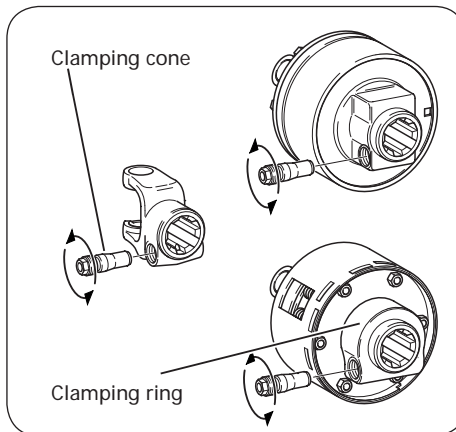
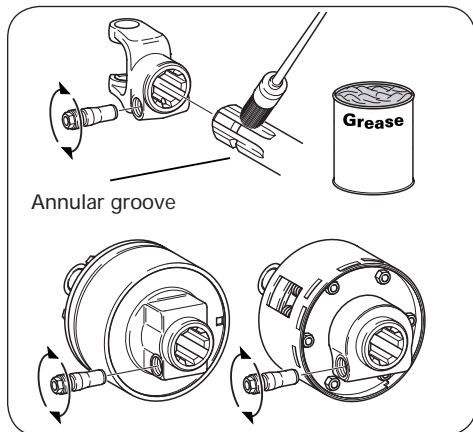
1. Dismantle guard (Figs. J1 - J3). Remove old cone (e.g. cut open with knife). Take off chain. Place neck of new cone in hot water (approx 80°C / 180°F) and pull onto bearing housing (Fig. L1).
2. Turn guard cone into assembly position (Fig. L2). Further assembly instructions for guard (Figs. K1 - K5).
3. Reconnect chain if required (Fig. L3).



## PTO Quick Disconnect

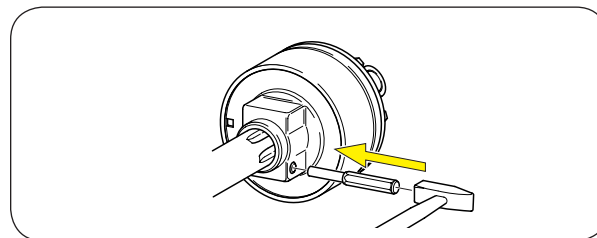
### Coupling

Slide clamp yoke or clutch onto connecting shaft. Make sure the location hole for the clamping cone is positioned above the annular groove of the connecting shaft. Screw appropriate clamping cone into the location hole. Slightly moving the clamp yoke or clutch to and from in the axial direction will help drive in the clamping cone. Check the clamp yoke or clutch for a tight and safe fit and continue to check at regular intervals. Retighten the clamping cone/pin as necessary. Torque pin down to 75 ft.-lbs.



### Uncoupling

Unscrew the pin a partial turn. Use the punch and hammer to help alleviate the torque resistance on the wrench if necessary. After a few cycles the pin will move freely with low torque resistance for the removal process.



## Wheel, Hub and Spindle Disassembly and Assembly

### **WARNING**

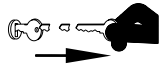
- **TIPPING OR MOVEMENT OF THE MACHINE CAN CAUSE SERIOUS INJURY OR DEATH. BE SURE MACHINE IS SECURELY BLOCKED.**
- **FALLING OBJECTS CAN CAUSE SERIOUS INJURY OR DEATH. DO NOT WORK UNDER THE MACHINE AT ANY TIME WHILE BEING HOISTED. BE SURE ALL LIFTING DEVICES AND SUPPORTS ARE RATED FOR THE LOADS BEING HOISTED. THESE ASSEMBLY INSTRUCTIONS WILL REQUIRE SAFE LIFTING DEVICES UP TO 20,000 LBS. SPECIFIC LOAD RATINGS FOR INDIVIDUAL LOADS WILL BE GIVEN AT THE APPROPRIATE TIME IN THE INSTRUCTIONS.**

### **CAUTION**

- **IMPROPERLY TORQUED WHEEL NUTS/BOLTS CAN CAUSE A LOSS OF IMPLEMENT CONTROL AND MACHINE DAMAGE. TORQUE WHEEL NUTS/BOLTS TO VALUES IN TABLE. CHECK TORQUE BEFORE USE, AFTER ONE HOUR OF UNLOADED USE OR AFTER FIRST LOAD, AND EACH LOAD UNTIL WHEEL NUTS/BOLTS MAINTAIN TORQUE VALUE. CHECK TORQUE EVERY 10 HOURS OF USE THERE-AFTER. AFTER EACH WHEEL REMOVAL START TORQUE PROCESS FROM BEGINNING. WARRANTY DOES NOT COVER FAILURES CAUSED BY IMPROPERLY TORQUED WHEEL NUTS/BOLTS.**

### **IMPORTANT**

- *Remove only one wheel and tire from a side at any given time in the following procedure.*

1. Hitch cart to tractor. Park the empty cart on a firm, level surface. Set the tractor's parking brake, shut off engine and remove key. 
2. With cart empty, use safe lifting and load holding devices rated at 15,000 lbs. to support the weight of your grain cart. Place the safe lifting device under the axle closest to the tire.
3. Use a 3,000 lbs. safe lifting device to support the wheel and tire during removal.
4. If only changing wheel and tire, skip to Step 8; otherwise continue with Step 4.

Remove the hardware retaining the hubcap. Next, remove the hubcap, gasket, cross bolt, castle nut and spindle washer. Remove hub with bearings from old spindle using a safe lifting device rated for at least 200 lbs.

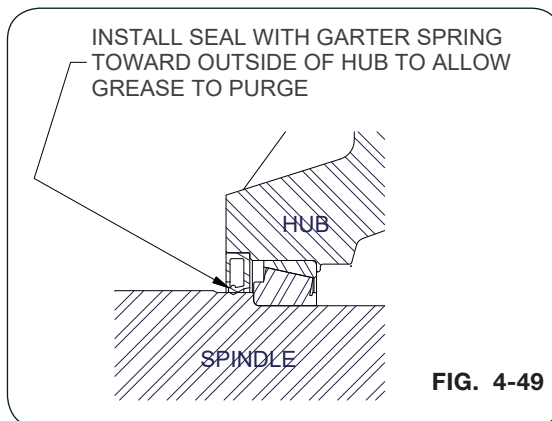


**Wheel, Hub and Spindle Disassembly and Assembly (continued)**

5. Inspect the spindle and replace if necessary. If spindle does not need to be replaced, skip to Step 6; otherwise continue with Step 5.

Remove the bolt and lock nut that retains the spindle to the axle. Using a safe lifting device rated for 150 lbs., replace the old spindle with a new spindle. Coat spindle shaft with anti-seize lubricant prior to installation. Reuse bolt and lock nut to retain spindle to axle. Tighten as outlined in Maintenance Section.

6. Remove seal and inspect bearings, spindle washer, castle nut and cotter pin. Replace if necessary. Pack both bearings with NLGI#2 EP approved grease and reinstall inner bearing. Install new seal with garter spring toward the outside of the hub to allow grease to purge. Using a safe lifting device rated for 200 lbs., install hub assembly onto spindle. Install outer bearing, spindle washer and castle nut. (Fig. 4-49)



7. Slowly tighten castle nut while spinning the hub until drag causes the hub to stop freely spinning. Do not use an impact! Turn castle nut counterclockwise until the hole in the spindle aligns with the next notch in castle nut. Hub should spin smoothly with little drag and no end play. If play exists, tighten to next notch of castle nut. If drag exists, then back castle nut to next notch of castle nut. Spin and check again. Install cotter pin. Clean face for hub cap gasket and install gasket, grease filled hub cap and retain hubcap with hardware removed. Tighten hubcap hardware in alternating pattern.
8. Attach the wheel(s) and tire(s) to the hub using the same rated lifting device for removal. Tighten wheel nuts to appropriate requirements and recheck as outlined in the Wheel and Tire section of this manual.
9. Raise cart, remove safe load holding devices and lower tire to the ground.

## Wheels and Tires

### Wheel Nut Torque Requirements

#### **⚠ CAUTION**

- IMPROPERLY TORQUED WHEEL NUTS/BOLTS CAN CAUSE A LOSS OF IMPLEMENT CONTROL AND MACHINE DAMAGE. TORQUE WHEEL NUTS/BOLTS TO VALUES IN TABLE. CHECK TORQUE BEFORE USE, AFTER ONE HOUR OF UNLOADED USE OR AFTER FIRST LOAD, AND EACH LOAD UNTIL WHEEL NUTS/BOLTS MAINTAIN TORQUE VALUE. CHECK TORQUE EVERY 10 HOURS OF USE THERE-AFTER. AFTER EACH WHEEL REMOVAL START TORQUE PROCESS FROM BEGINNING. WARRANTY DOES NOT COVER FAILURES CAUSED BY IMPROPERLY TORQUED WHEEL NUTS/BOLTS.

Failure to check torque before first load may damage wheel nut/bolt seats. Once seats are damaged, it will become impossible to keep nuts/bolts tight. Tighten nuts/bolts to applicable torque value shown in table. Start all nuts/bolts by hand to prevent cross threading. Torque nuts/bolts in the recommended sequence as shown in Diagram 1.

**NOTE:** Do not use anti-seize on wheel hardware.

WHEEL HARDWARE	
SIZE	TORQUE
M22x1.5	475 ft.-lbs.

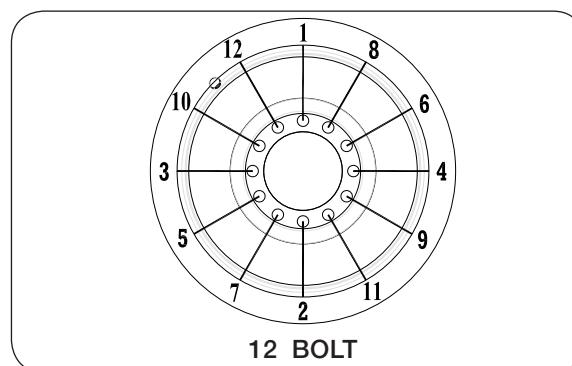


DIAGRAM 1

**Wheels and Tires** (continued)

**Tire Pressure**

The following is to be used as a general guide for tire inflation and figures can vary depending on specific brand of tire used. **IT IS IMPORTANT THAT TIRES ARE INSPECTED AFTER UNIT IS LOADED.** Start with minimum pressure indicated. The tire should stand up with no side-wall buckling or distress as tire rolls. Record the pressure needed to support the full load and maintain this pressure to achieve proper tire life. **DO NOT EXCEED MAXIMUM RECOMMENDED TIRE PRESSURE.** Each tire must be inflated to 35 PSI max to seat the beads, deflated to 5-10 PSI, then reinflated to the tire's max PSI when mounting.

**Tire Pressure for Grain Carts**

Tire Make	Tire Size	Load Index / Ply	
		Rating	Max. PSI
Firestone	23.1x26 R-3	12	32
	23.1x26 R-1	12	32
	28Lx26 R-3	12	26
	24.5x32 R-3	12	32
	24.5x32 R-1	12	32
	30.5x32 R-1	14	28
	30.5x32 R-3	14	28
	30.5x32 R-3	16	34
	30.5x32 R-1	16	26
	35.5x32 R-3	20	36
	76x50.00x32 HF-3	16	40
	76x50.00x32 HF-3	20	50
	800/65R32 R-1W	172D	41
	800/60R32 R-3	181B	46
	900/65R32 R-3	191B	46
	900/60R32 R-1	176A8	44
	1250/50R32F IF/CFO R-1WNP	201D	46
	1250/50R32F IF/CFO R-1W	188B	30
	520/85R38 R-1	155A8	29
	520/85R38 R-1	173A8	64
	480/80R42 R-1	151A8	36
	520/85R42 R-1	157A8	29
	520/85R42 R-1	165A8	51
	520/85R42 IF/CFO R-1	169A8/B	35
	IF520/85R42 R-1W	169B	35
	VF520/85R42 R-1W	177B	35
	420/80R46 R-1	151A8	44
	480/80R46 R-1	158A8	44
	380/90R46 R-1	152B	51

**Wheels and Tires (continued)**

**Tire Pressure (continued)**

<b>Tire Pressure for Grain Carts</b>			
<b>Tire Make</b>	<b>Tire Size</b>	<b>Load Index / Ply Rating</b>	<b>Max. PSI</b>
<b>Titan/Goodyear</b>	23.1x26 R-3	10	26
	23.1x26 R-1	10	26
	24.5R32 R-1	169A8/B (5-Star)	48
	24.5x32 R-3	12	32
	24.5x32 R-1	12	32
	30.5x32 R-3	16	26
	30.5x32 R-3	14	22
	30.5x32 R-1	14	22
	480/80x42 R-1	166A8	23
	1100/45R46 F-1W	195D	35
<b>Mitas</b>	650/75R32 R-1W	172A8	58
	650/75R32 R-1	176A8	41
	800/65R32 R-1W	172A8	46
	900/60x32 R-1W	176A8	41
	900/70R32 R-1W	188A8	53
	1050/50x32 R-1W	178A8	41
	1250/50R32 R-1W	188A8	41
	900/60x38 R-1W	181A8	44
	520/85x42 R-1W	162A8	44
	650/65x42 R-1W	168A8	44
<b>Alliance</b>	30.5B32	18-Ply	36
	35.5LR32	193A8	44
	900/60R32 R-1W	192D	46
	1050/50R32 R-1W	185A8	52
	1250/50R32 R-1W	201B	46
<b>Trelleborg</b>	VF1050/50R32 R-1	198D	52
	900/50R32 R-1W	181A8	55
	900/60x32	176LI	44
	850/55R42 R-1W	161A8	32

**Wheels and Tires (continued)**

**Tire Warranty**

For questions regarding new tire warranty, please contact your local original equipment tire dealer. **USED TIRES CARRY NO WARRANTY.** Following are phone numbers and Websites for your convenience:

Firestone                      [www.firestoneag.com](http://www.firestoneag.com)  
Phone 800-847-3364

Titan                              [www.titan-intl.com](http://www.titan-intl.com)  
or Phone 800-USA-BEAR  
Goodyear                      Fax 515-265-9301

Trelleborg                      [www.trelleborg.com](http://www.trelleborg.com)  
Phone 866-633-8473

Continental/Mitas              [www.mitas-tires.com](http://www.mitas-tires.com)  
Phone 704-542-3422  
Fax 704-542-3474

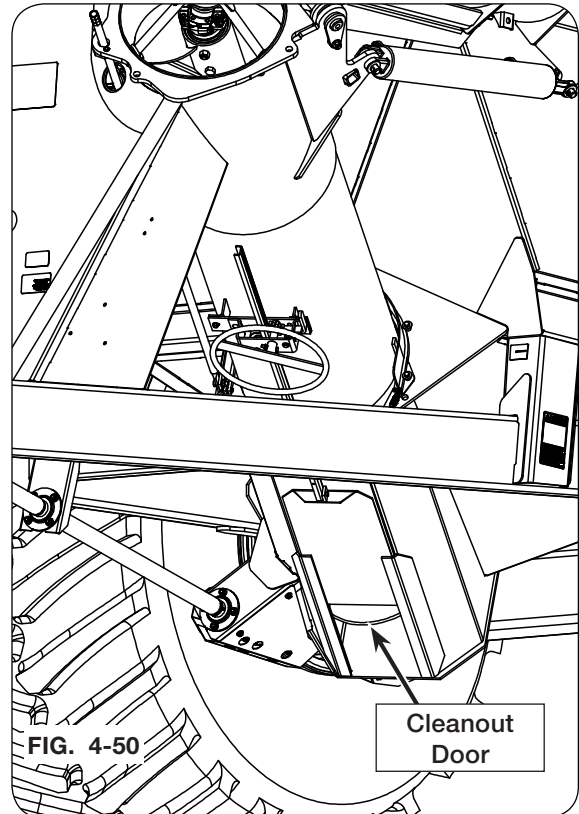
Alliance                         [www.atgtire.com](http://www.atgtire.com)  
Phone 781-325-3801

## Seasonal Storage

Your cart is an important investment. Spend a little time to protect it from destructive rust and corrosion. You will be repaid in longer service life and better performance.

Do the following before placing the cart in storage:

1. Remove dirt and trash which could cause rusting.
2. Repaint any chipped or scraped areas.
3. Lubricate points as shown on previous page.
4. Inspect for damage or worn parts, replace before next season.
5. Store cart inside, away from livestock.
6. Replace all worn, torn or faded decals and reflectors.
7. Fully open flow door and auger cleanout door to remove any remaining grain and to allow moisture to drain.
8. Close the tarp to keep debris out of the hopper.



## Hydraulic Jack Cylinder Replacement

### **WARNING**

- HIGH-PRESSURE FLUIDS CAN PENETRATE THE SKIN AND CAUSE SERIOUS INJURY OR DEATH. LEAKS OF HIGH-PRESSURE FLUIDS MAY NOT BE VISIBLE. USE CARDBOARD OR WOOD TO DETECT LEAKS IN THE HYDRAULIC SYSTEM. SEEK MEDICAL TREATMENT IMMEDIATELY IF INJURED BY HIGH-PRESSURE FLUIDS.
- RELIEVE THE HYDRAULIC SYSTEM OF ALL PRESSURE BEFORE ADJUSTING OR SERVICING. SEE THE HYDRAULIC POWER UNIT OPERATOR'S MANUAL FOR PROPER PROCEDURES.
- HYDRAULIC SYSTEM MUST BE PURGED OF AIR BEFORE OPERATING TO PREVENT SERIOUS INJURY OR DEATH.
- MOVING OR ROTATING COMPONENTS CAN CAUSE SERIOUS INJURY OR DEATH. ENSURE SERVICE COVERS, CHAIN/BELT COVERS AND CLEAN-OUT DOOR ARE IN PLACE AND SECURELY FASTENED BEFORE OPERATING UNIT.
- UNHITCHING A LOADED CART CAN CAUSE SERIOUS INJURY OR DEATH DUE TO TONGUE RISING OR FALLING. ALWAYS HAVE A LOADED CART ATTACHED TO A TRACTOR. THE JACK IS INTENDED TO SUPPORT AN EMPTY CART ONLY.
- FALLING OBJECTS CAN CAUSE SERIOUS INJURY OR DEATH. DO NOT WORK UNDER THE MACHINE AT ANY TIME WHILE BEING HOISTED. BE SURE ALL LIFTING DEVICES AND SUPPORTS ARE RATED FOR THE LOADS BEING HOISTED. THESE ASSEMBLY INSTRUCTIONS WILL REQUIRE SAFE LIFTING DEVICES UP TO 100 LBS. SPECIFIC LOAD RATINGS FOR INDIVIDUAL LOADS WILL BE GIVEN AT THE APPROPRIATE TIME IN THE INSTRUCTIONS.

1. Park the empty unit on a firm, level surface. Block tractor and machine to keep it from moving. Set the tractor parking brake, shut off the engine and remove the ignition key. Completely disconnect the PTO from the cart and tractor.

2. Attach hydraulic jack hoses to tractor SCV.

3. Open valve and lower jack leg to ground. DO NOT raise tongue.



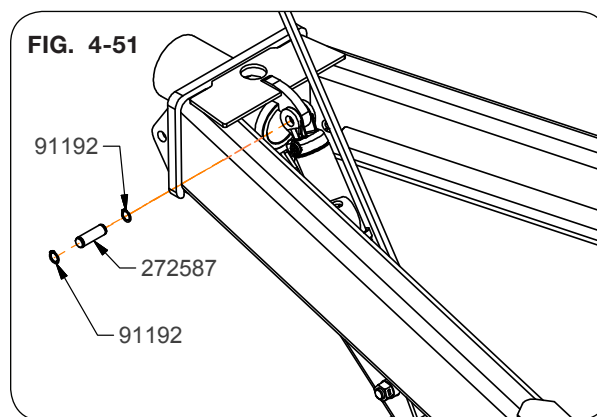
4. Relieve pressure on hydraulic jack circuit. See tractor operator manual for procedure.

5. Close valve.

6. Support the hydraulic jack assembly with a safe lifting device rated for a minimum of 100 lbs.

7. Remove hydraulic jack hoses from tractor SCV.

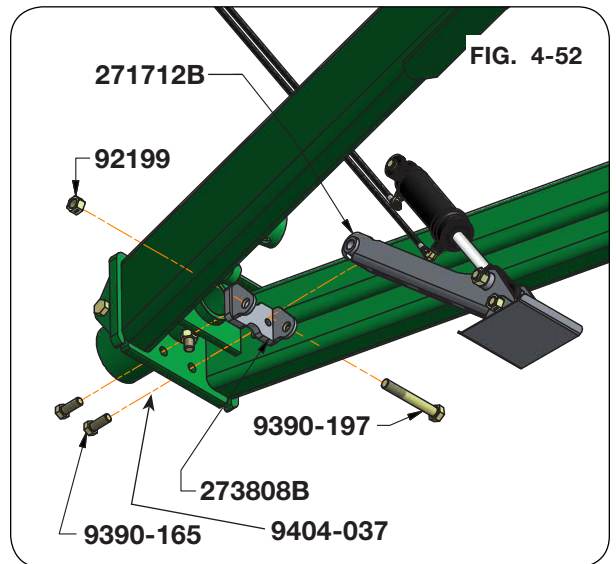
8. Remove cylinder pin (272587) and snap rings (91192) from the base end of the cylinder at the lug on top of the tongue. (Fig. 4-51)



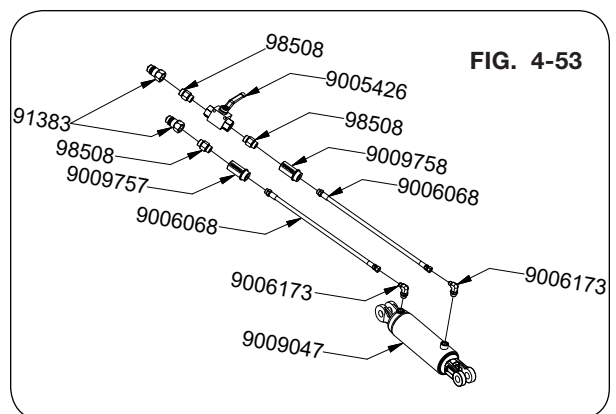


**Hydraulic Jack Cylinder Replacement** (continued)

9. Remove two 7/8"-9UNC x 2 1/4" capscrews (9390-165) and 7/8" lock washers (9404-037) from mounting bracket (273808B). (Fig. 4-52)
10. Remove hydraulic jack assembly from the tongue. (Fig. 4-52)



11. On new hydraulic assembly (273849B), attach hoses (9006068) and fittings to cylinder (9009047). (Fig. 4-53) The valve needs to be assembled to the hose on the base end of the cylinder. Assemble the fittings on the cylinder so they face each other, then store the hydraulic hoses on the hose caddy.
12. To reassemble hydraulic jack, see "Optional Hydraulic Jack" in SET UP section.



**Troubleshooting**

<b>Problem</b>	<b>Possible Cause</b>	<b>Corrective Action</b>
No Electric Over Hydraulic (EOH) Functions work	Not getting 12 Volt power supply to the power harness in the tractor	Check the connections to the main power harness in the tractor cab, and check the 5 AMP fuse in the fuse holder of the main power harness. Replace fuse if necessary. Make sure the joystick and 7-pin connector are plugged into the same power source. If plugged into different power sources, the spout rotate and auger fold functions WILL NOT operate properly.
	Not getting good connection at Deutch connectors in the harnesses	Unplug the Deutsch connectors at the hitch point and in the extension harness (if used). Clean up the connectors with electrical contact cleaner. Make sure the connectors are aligned correctly and re-connect them.
	Not pressurizing the correct hydraulic hose	Make sure the quick couplers are properly connected to the tractor SCV and the Hydraulic Pressure line is being pressurized when engaging the tractor SCV.
Auger unfolds, but won't fold back in to transport position	Rotating Spout is not in the folding position	Rotate the spout so it is positioned straight down or forward in order to fold the auger into transport position.
	Rotating spout switch is faulty or out of adjustment	Make sure the spout is in the centered position. Refer to the manual override sections in order to fold the auger back into transport position. The clearance between the end of the proximity switch and the barrel of the rotating spout cylinder must not exceed 1/4".
Auger unfolds part way and stops	Debris in the EOH block on the auger fold cylinder	Fold auger, remove the Coil and the cartridge valve on the EOH valve block. Remove any debris and reinstall cartridge and coil.
	Rotating Spout switch is out of adjustment or has been activated.	With the auger folded in to the transport rest, have someone depress and hold the switch at the vertical auger hinge plate. Use any means necessary to depress the switch without placing your hands or other body parts near the pinch points. With the switch depressed, rotate the spout to the folding position.

**Troubleshooting**

<b>Problem</b>	<b>Possible Cause</b>	<b>Corrective Action</b>
Rotating spout will not function	7 pin connector is not plugged into tractor.	Plug in 7 pin connector to same power source as the 5 function controller.
	Proximity Switch at the auger hinge is not getting Power or Ground.	Check power and ground to the proximity switch harness on the vertical auger.
	Proximity Switch at the hinge plate is not adjusted correctly	This proximity switch has a 1/4" effective operating range. The upper auger hinge plate needs to be within that range when it is unfolded in to the operating position. Adjust the proximity switch in or out in order for the sensor to activate when it is in the operating position.
	Switch located at the hinge plate of the vertical auger is not getting power, ground or is defective	Check the ground wire on the top plate of the lower vertical auger and on the left hand standard just behind the front plate of the harness. Unplug the 3 pin connector on the hinge plate proximity switch. With a multi-meter or test light, confirm that the pin in socket B has +12V constant power and socket A has +12V when the sensor is activated.
	Cartridge valve(s) on the EOH valve block are not locked in center position.	Check the cartridge valve(s) on the EOH valve block are locked in center position. Remove any debris on the cartridge valve(s). Refer to "Manual Override for Opt. Electric Over Hydraulic System" in MAINTENANCE section.
One single function will not work	Defective coil on the EOH valve for that function	Loosen the cap for the coils associated with that function on the EOH valve. Depress the button on the remote, and determine if the coils are getting magnetized. Inspect the wiring connectors to these coils, and replace the coil if necessary.
	Defective valve on the EOH valve for that function	Remove the coil and the cartridge valve on the EOH valve block for that function. Replace the valve if it doesn't operate when the coil is magnetized.
	Debris in the EOH block at the base of the vertical auger	Remove the coil and the cartridge valve on the EOH valve block. Remove any debris and reinstall cartridge and coil.
Functions continue to operate after the button on the remote is released	Tractor hydraulic flow is set too high	Turn tractor hydraulic flow down so that flow doesn't exceed 6 gallons per minute.
	Defective valve on the EOH valve for that function	Remove the coil and the cartridge valve on the EOH valve block for that function, and replace the cartridge.

## Tarp Troubleshooting Inspection & Maintenance

PROBLEM	SOLUTION
TARP SAGS IN MIDDLE AREAS	<ol style="list-style-type: none"> <li>1. BOWS MAY BE BENT OR ADJUSTED TOO LOW</li> <li>2. MISSING OR LOOSE RIDGE STRAP REPLACE OR RETIGHTEN</li> <li>3. TENSION MAY BE TOO LOOSE. U-JOINT MAY NEED TO BE ADJUSTED ON SPLINED SHAFT TO PROVIDE MORE TENSION</li> </ol>
HOLES OR TEARS IN TARP	<ol style="list-style-type: none"> <li>1. CONSULT YOUR LOCAL DEALER FOR REPAIRS</li> <li>2. ORDER TARP REPAIR KIT FROM DEALER</li> <li>3. WHEN NEW TARP OR PARTS ARE NEEDED ALWAYS REPLACE WITH ORIGINAL PARTS</li> </ol>

### Inspection and Maintenance

#### **WARNING**

- TO PREVENT PERSONAL INJURY OR DEATH, DO NOT ALLOW ANYONE ON A CLOSED TARP. TARP SYSTEM IS NOT DESIGNED TO SUPPORT A PERSON.
- FALLING OBJECTS CAN CAUSE SERIOUS INJURY OR DEATH. REMOVE ACCUMULATED WATER/SNOW/ICE OR ANY OTHER OBJECTS FROM TARP BEFORE OPENING TARP.

#### **IMPORTANT**

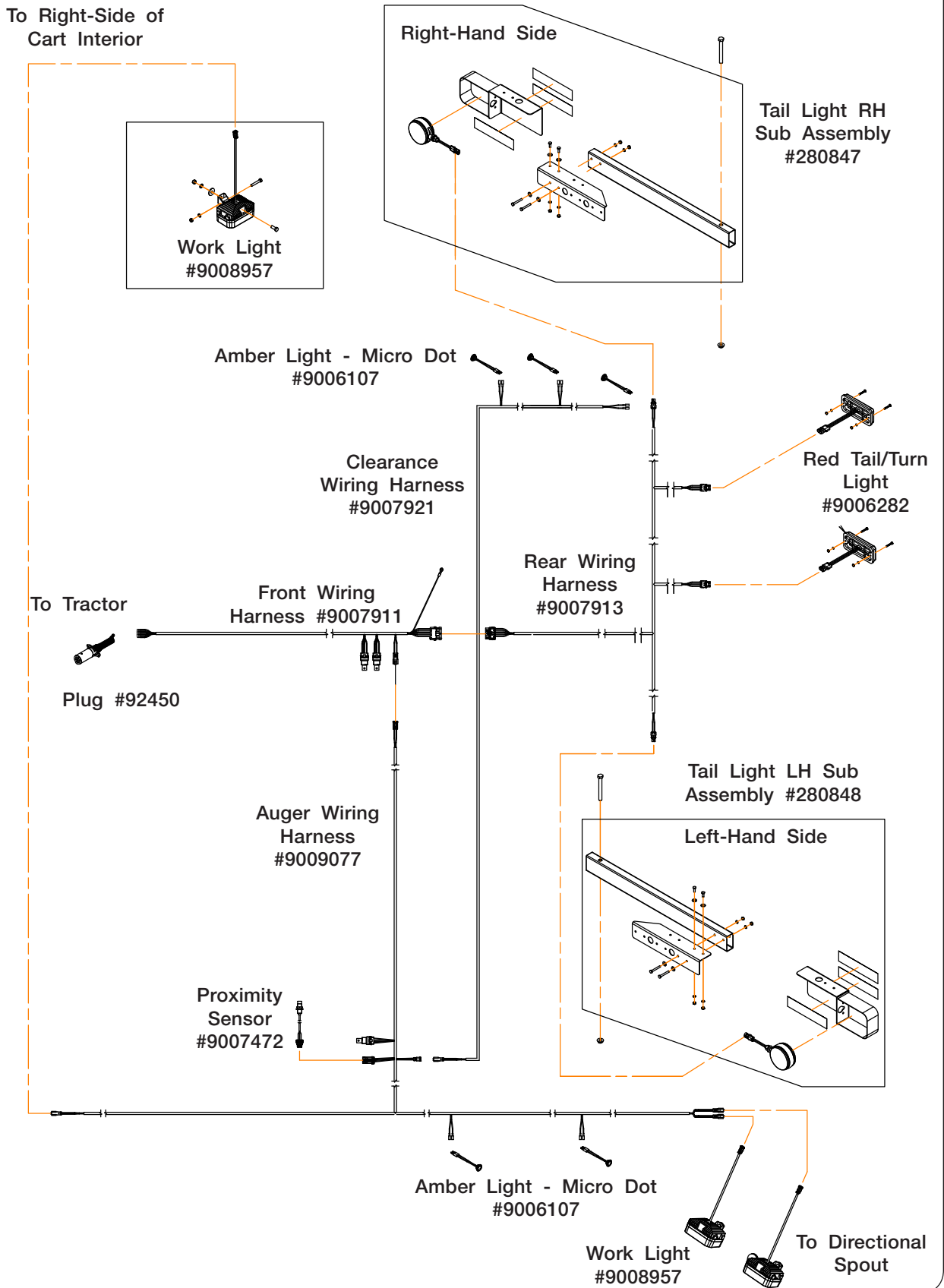
- *Do not open or close tarp while moving or in high wind conditions. Damage to the tarp may occur.*
- *Tarp should not be used if it is torn or the bungee cords are frayed or show damage. Fully close tarp with tension on the latch plate to prevent water from pooling.*

Periodic preventive maintenance should be practiced. Inspect tarp and hardware often for abrasions or loosened bolts that may need adjustment and/or repair. Check bungee cords for wear and adjust tension at the beginning of the season and again half way through the season.

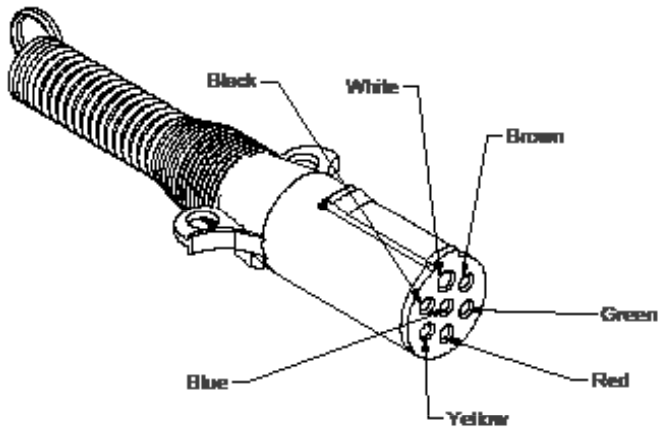
Tears in tarp should be addressed before further tarp operation. If water pools on tarp, adjust tension of tarp cables and/or crank handle tension.

If installed correctly, tarp should always operate as well as when first installed. If tarp does not pass this simple inspection, make all appropriate repairs or adjustments immediately before serious damage occurs.

Electrical System Diagram



**Electrical System Diagram — Plug #92450**

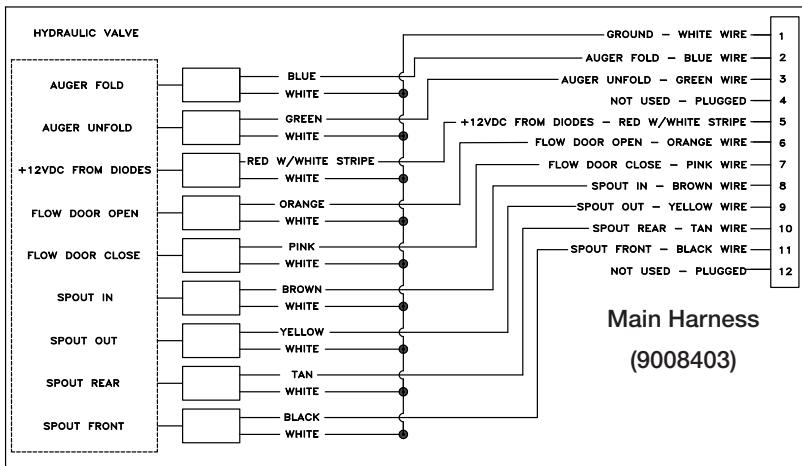
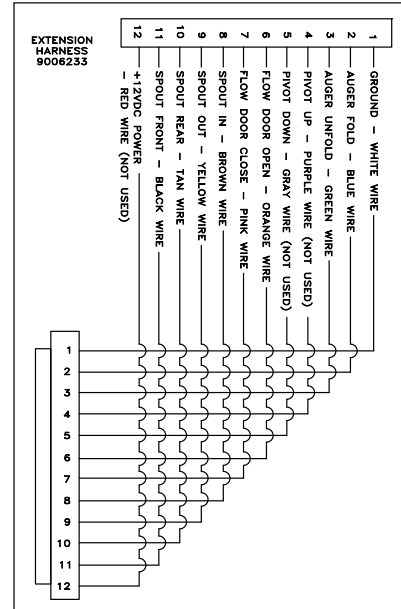
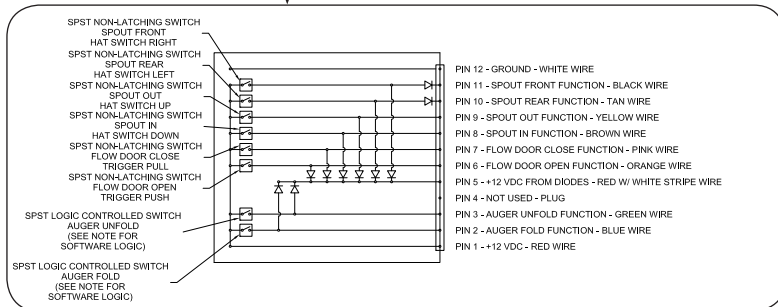
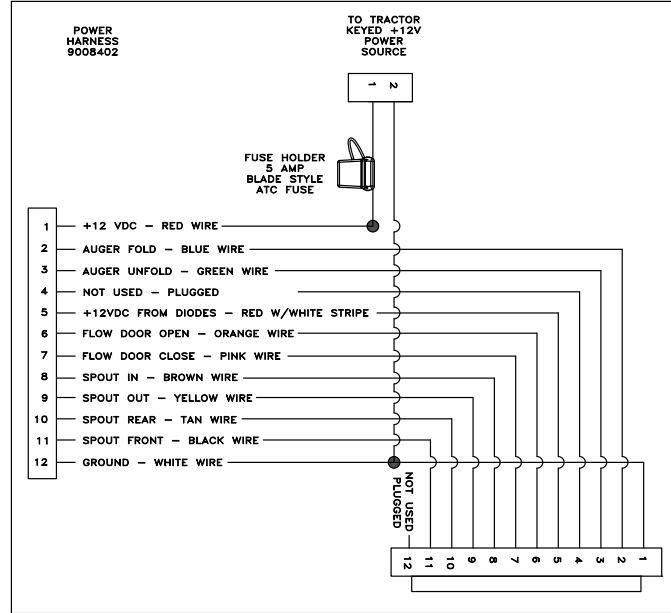
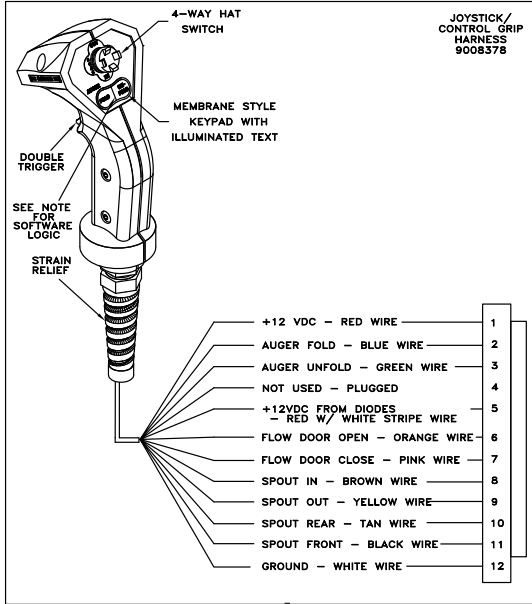


**GRAIN CART WIRES**

- White - Ground
- Green - Right amber flashing lamp
- Yellow - Left amber flashing lamp
- Brown - Tail light
- Black - Interior & Auger Lights
- Red - Brake Lights
- Blue - (Not Used)

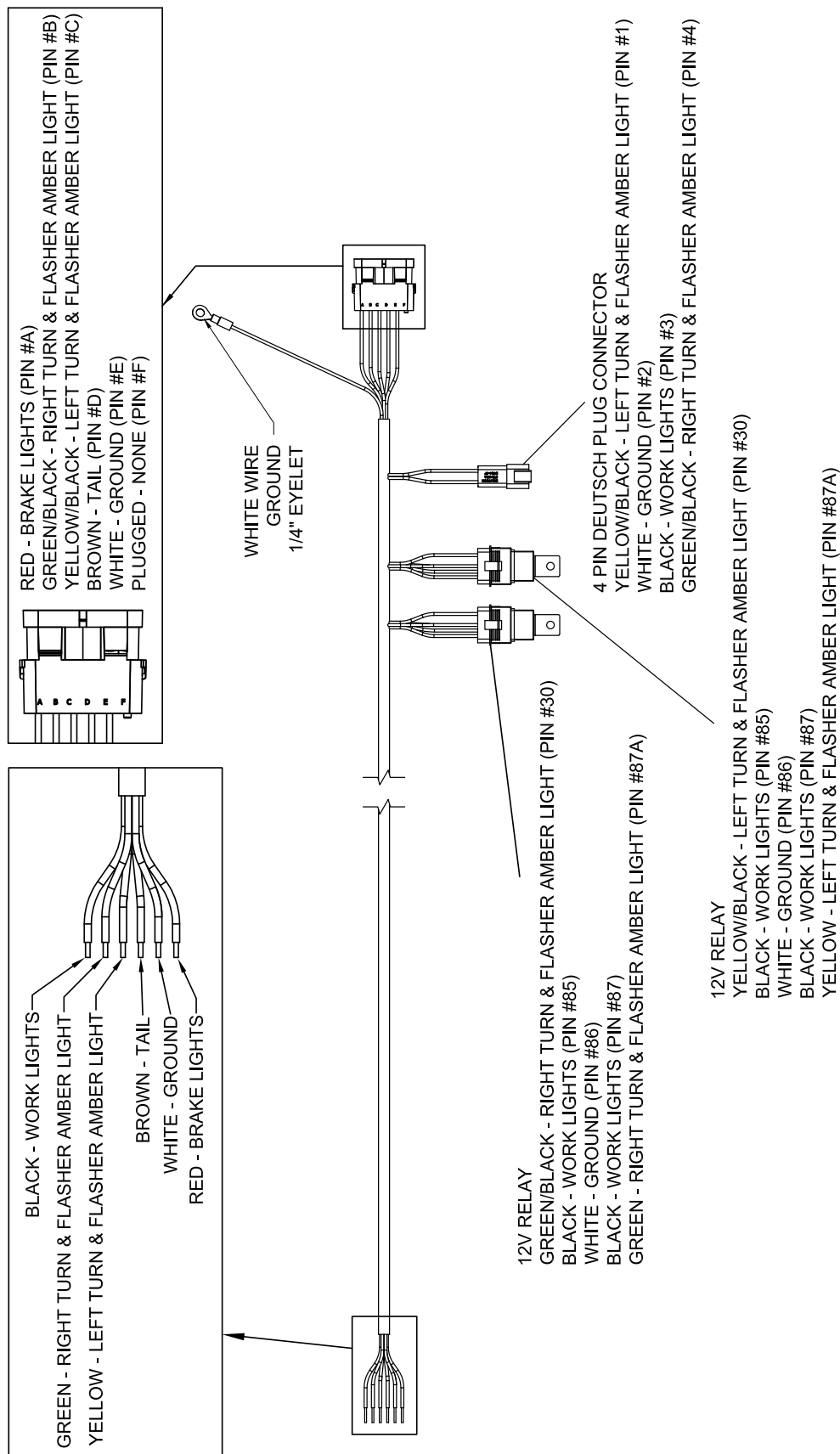
## Electric Over Hydraulic (EOH) System Schematic 4 Function Optional

**NOTE:** The joystick and 7-pin connector MUST be plugged into the same power source. If plugged into different power sources, the spout rotate and auger fold functions WILL NOT operate normally.

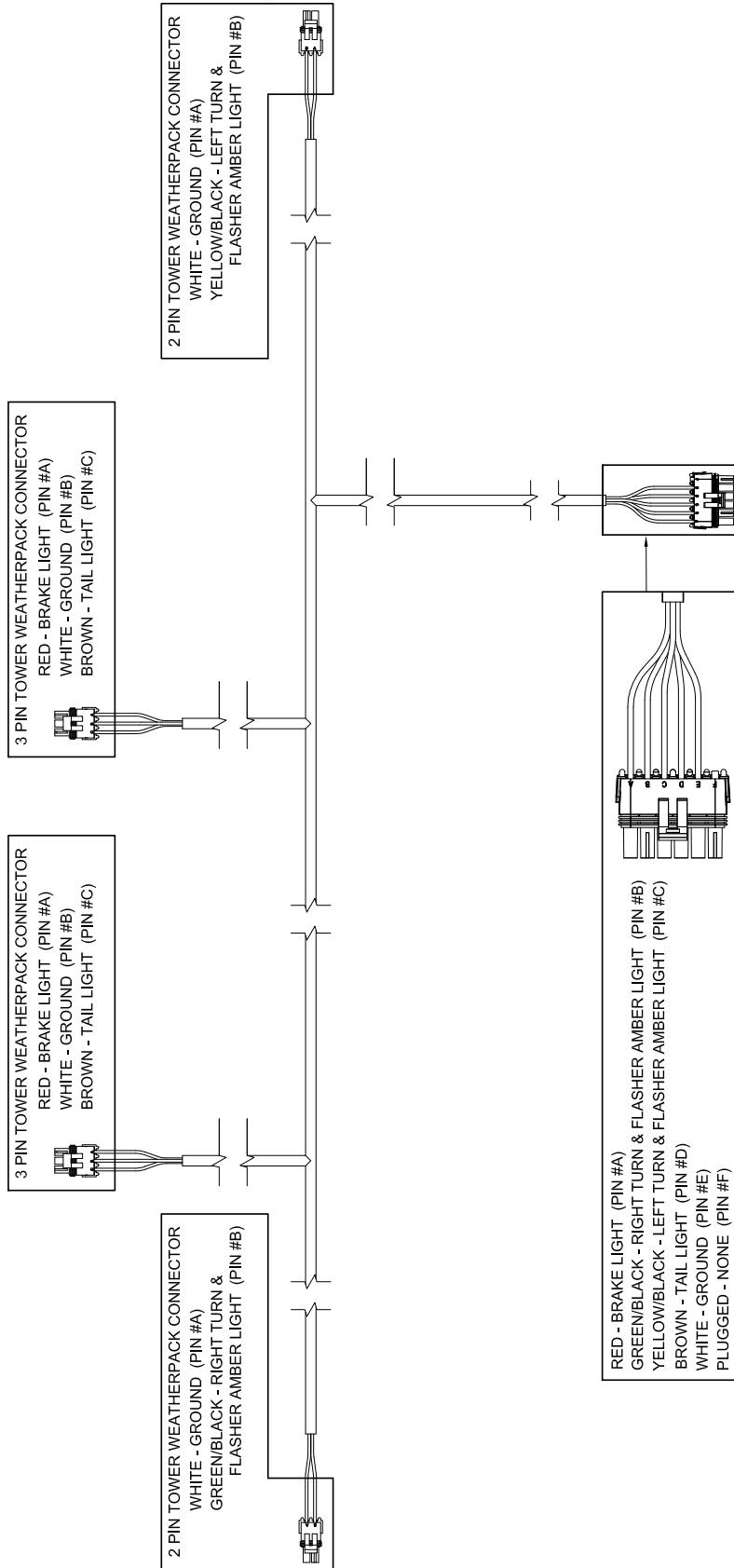




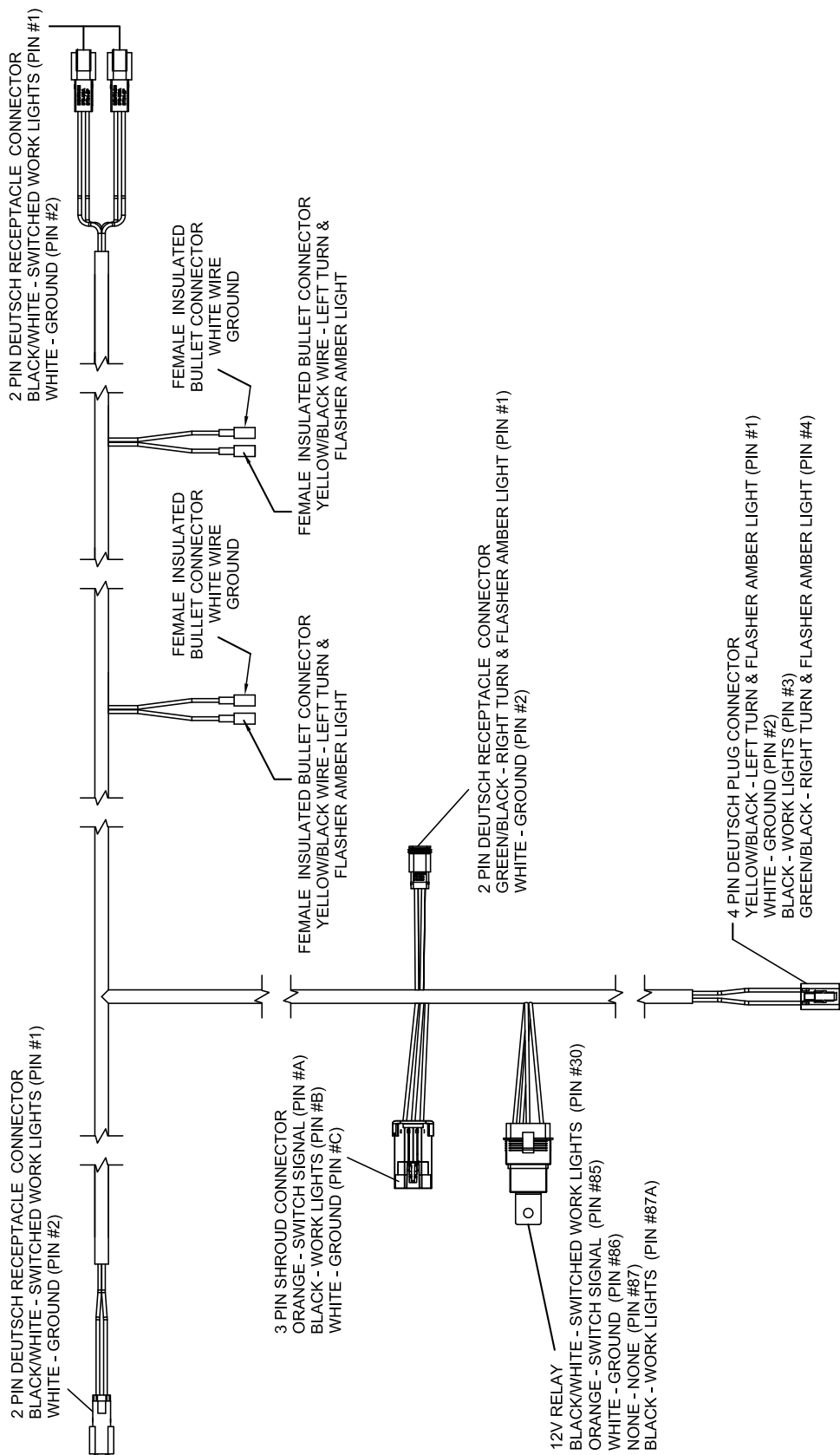
Electrical Diagram — Front Wiring Harness #9007911



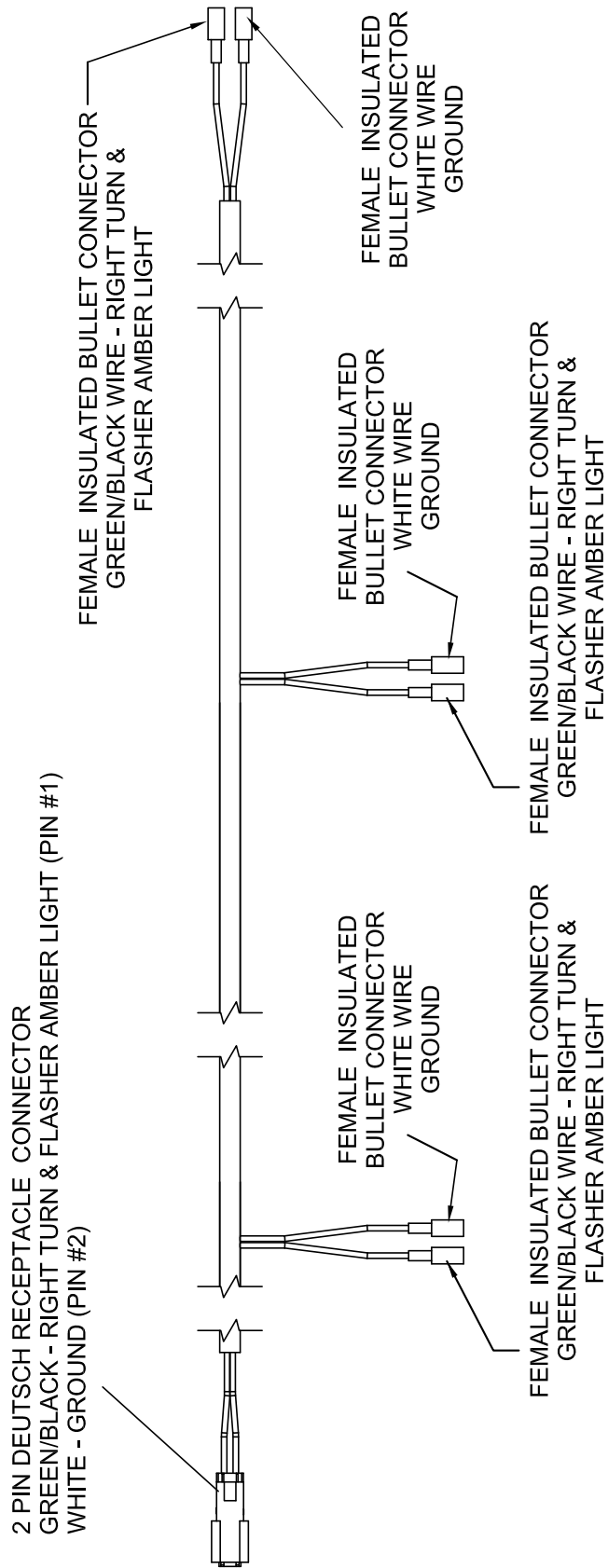
Electrical Diagram — Rear Wiring Harness #9007913



Electrical Diagram — Auger Wiring Harness #9009077

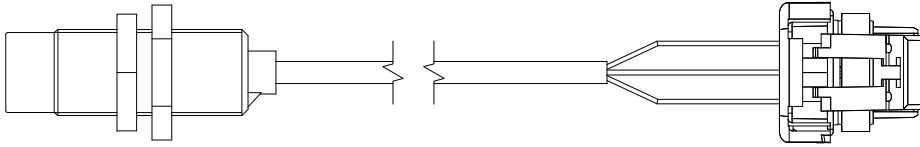


Electrical Diagram — Clearance Wiring Harness #9007921



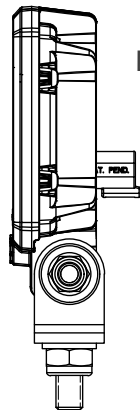
**Electrical Diagram — Proximity Sensor #9007472**

3 PIN FEMALE CONNECTOR



BLACK - SIGNAL (PIN #A)  
BROWN - +12 V DC (PIN #B)  
BLUE - GROUND (PIN #C)

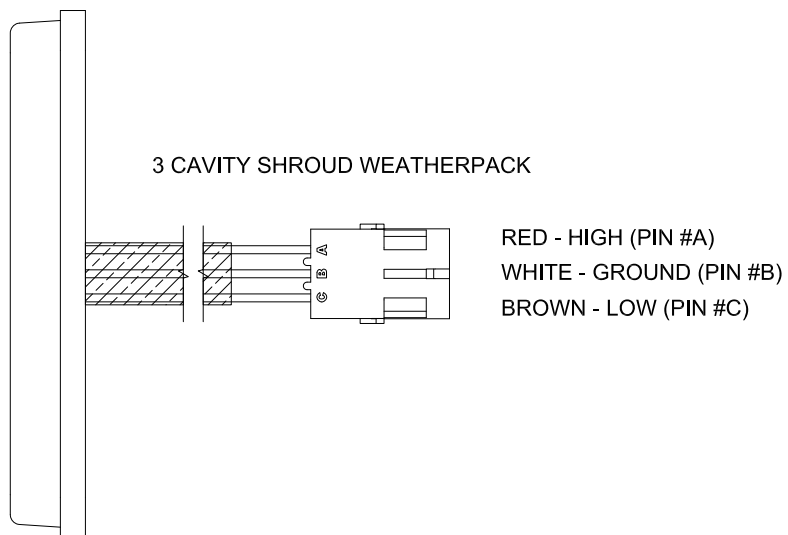
**Electrical Schematic — Work Light #9008957**



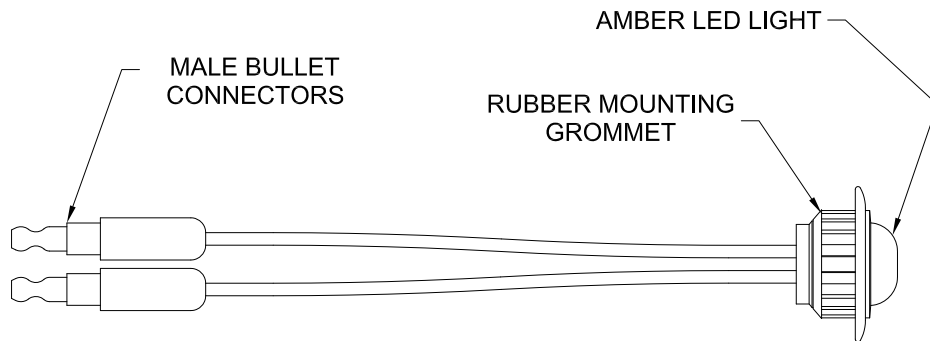
2 PIN INTEGRATED  
DEUTSCH CONNECTOR

POWER (PIN #1)  
GROUND (PIN #2)

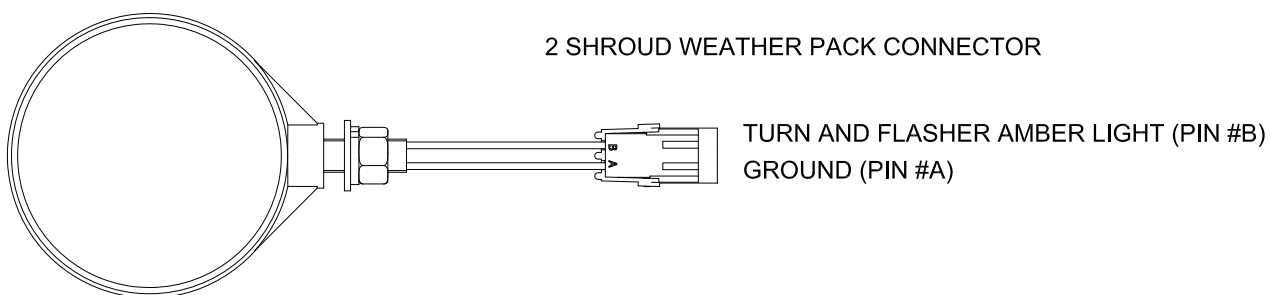
**Electrical Diagram — Red Tail/Turn Light #9006282**



**Electrical Diagram — Amber Light - Round Side Marker #9006107**

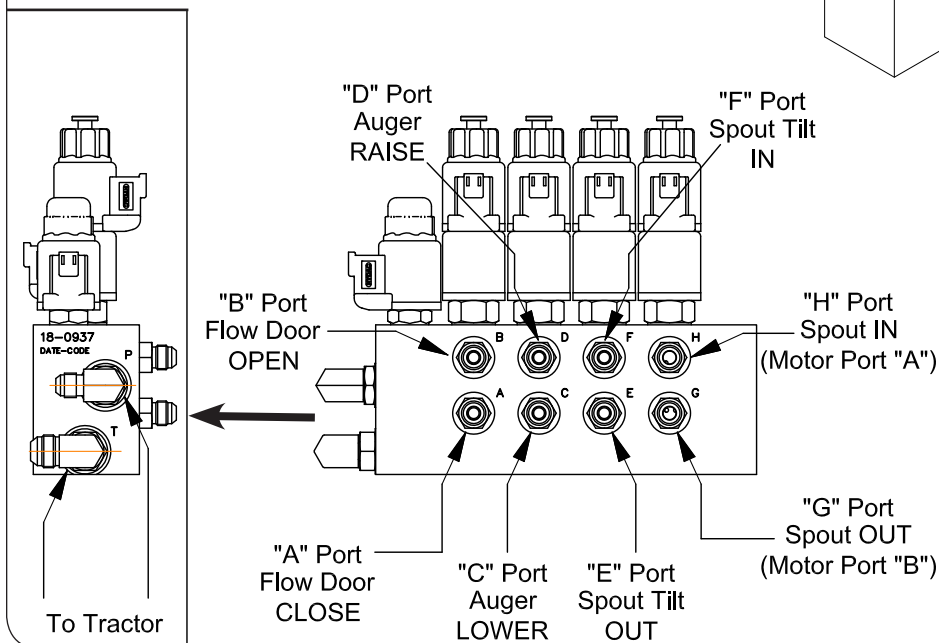
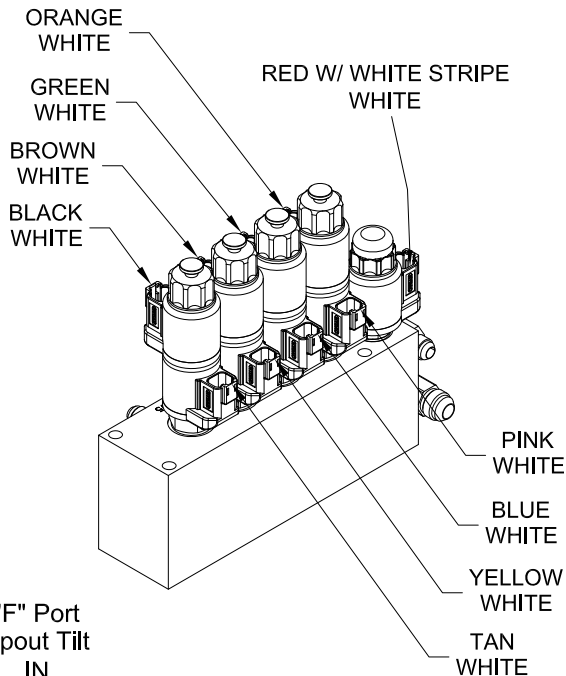


**Electrical Diagram — Amber Lamp Double Face #9005142**



**EOH Valve Functions and Wire Locations 4 Spool (Optional)**

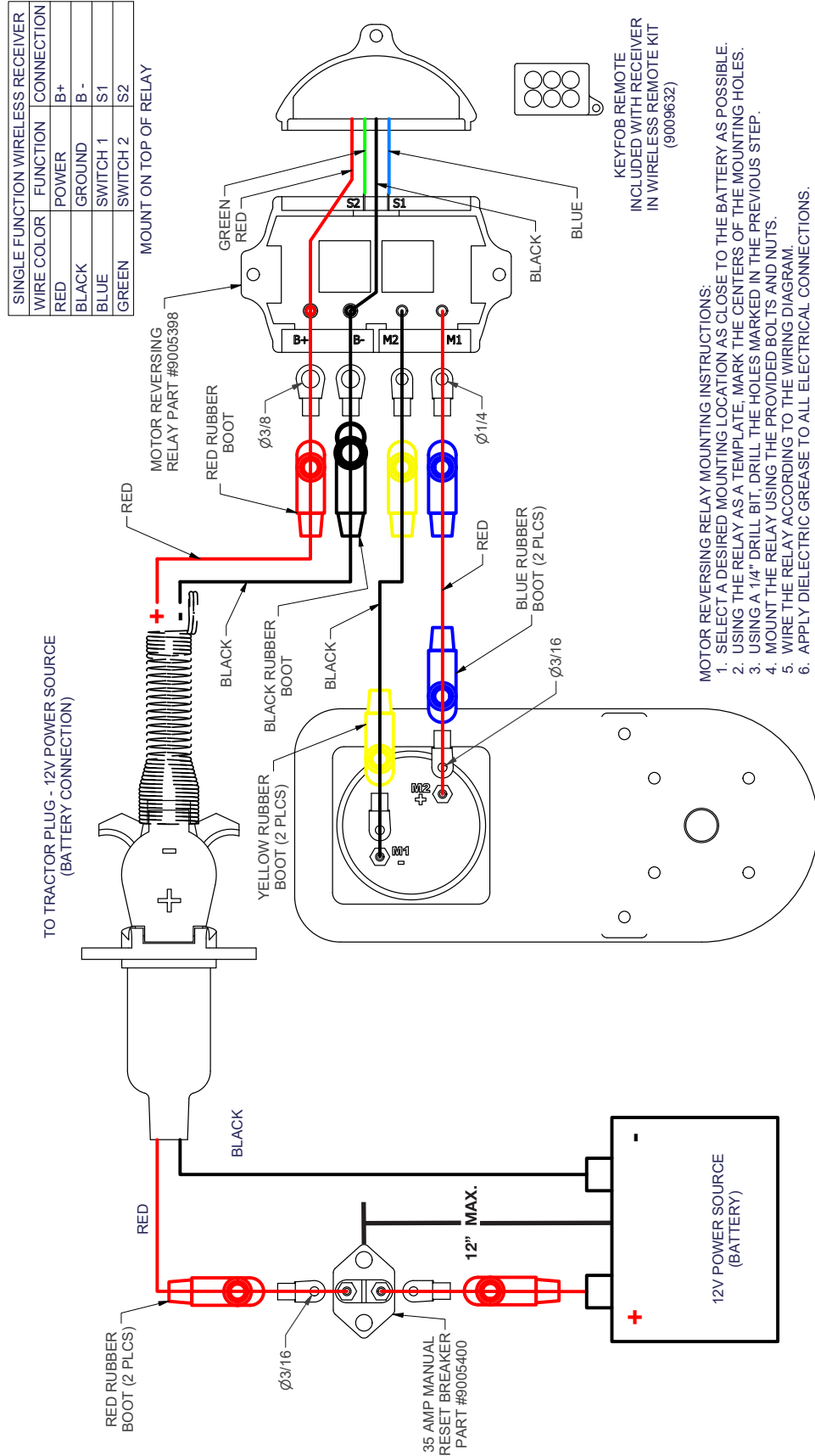
**NOTE:** For hydraulic connections chart, refer to “Hitching to Tractor - Hydraulic Connections” in the OPERATION section.



PORT	END OF CYLINDER	FUNCTION
A	BUTT END	Flow Door CLOSE
B	RAM END	Flow Door OPEN
C	RAM END	Auger Fold LOWER
D	BUTT END	Auger Fold RAISE
E	RAM END	Spout Tilt OUT
F	BUTT END	Spout Tilt IN
G	RAM END	Spout OUT
H	BUTT END	Spout IN
P		Tractor Pressure
T		Tractor Return



Electrical System Schematic - Optional Wireless Electric Tarp

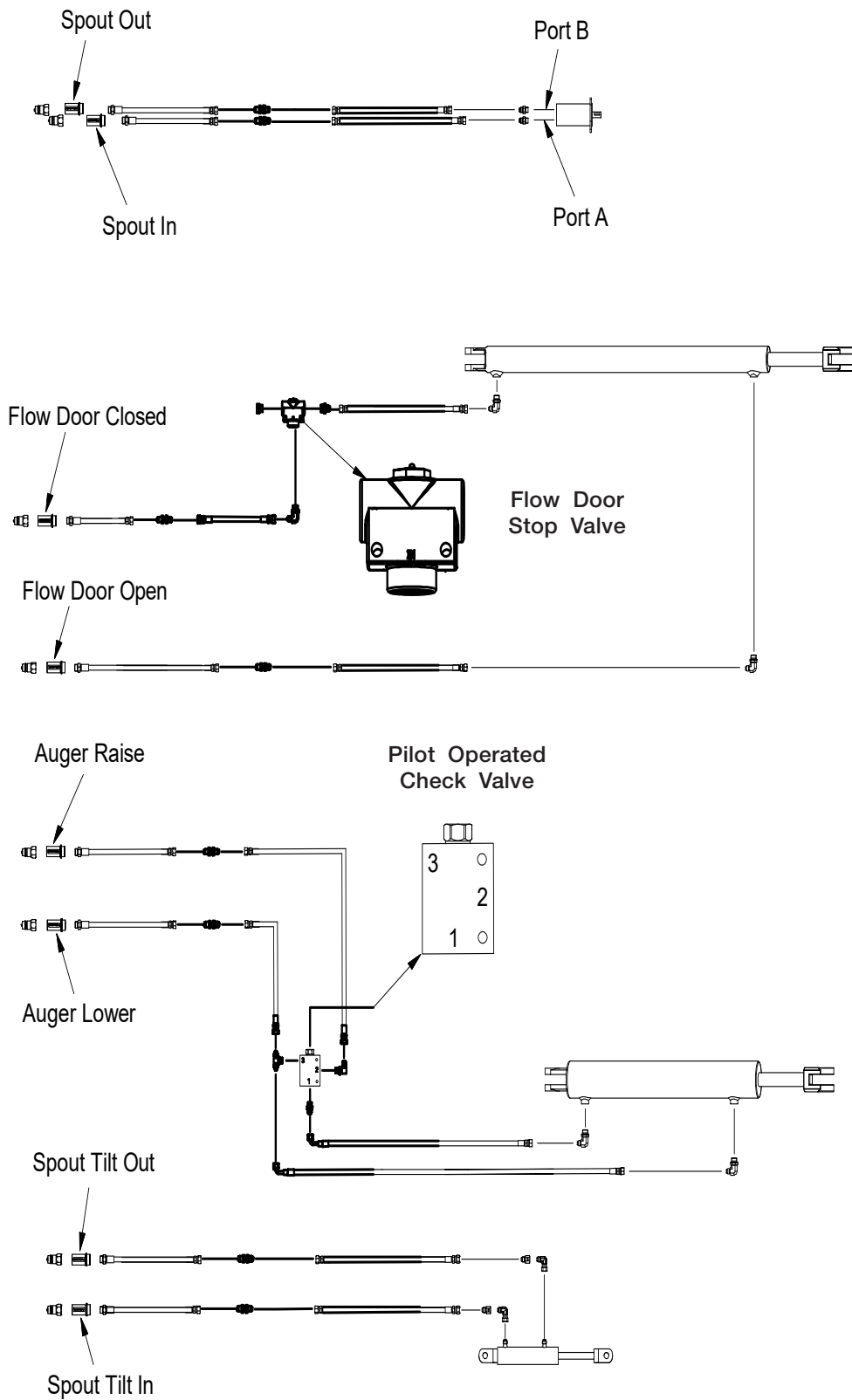


- MOTOR REVERSING RELAY MOUNTING INSTRUCTIONS:**
1. SELECT A DESIRED MOUNTING LOCATION AS CLOSE TO THE BATTERY AS POSSIBLE.
  2. USING THE RELAY AS A TEMPLATE, MARK THE CENTERS OF THE MOUNTING HOLES.
  3. USING A 1/4" DRILL BIT, DRILL THE HOLES MARKED IN THE PREVIOUS STEP.
  4. MOUNT THE RELAY USING THE PROVIDED BOLTS AND NUTS.
  5. WIRE THE RELAY ACCORDING TO THE WIRING DIAGRAM.
  6. APPLY DIELECTRIC GREASE TO ALL ELECTRICAL CONNECTIONS.

**NOTE:** See separate electric tarp manual for additional information.

WIRELESS ELECTRIC TARP

### Hydraulic System Plumbing Diagram



**Complete Torque Chart**

**Capscrews - Grade 5**

**NOTE:**

- Grade 5 capscrews can be identified by three radial dashes on the head.
- For wheel torque requirements, refer to Wheels and Tires.
- Tighten U-bolts evenly and equally to have the same number of threads exposed on each end.



SIZE	FOOT POUNDS	NEWTON METERS
1/4-20	8-10	11-13
1/4-28	9-11	12-15
5/16-18	15-17	20-23
5/16-24	17-19	23-26
3/8-16	25-28	34-38
3/8-24	28-31	38-42
7/16-14	40-45	54-61
7/16-20	45-50	61-68
1/2-13	62-68	84-92
1/2-20	68-75	92-102
9/16-12	90-98	122-133
9/16-18	100-110	134-148
5/8-11	120-135	162-183
5/8-18	124-137	168-186
3/4-10	200-220	270-300
3/4-16	210-230	285-310
7/8-9	330-350	425-475
7/8-14	360-380	460-515
1-8	500-525	675-710
1-14	540-560	730-760
1 1/8-7	600-635	815-860
1 1/8-12	665-700	920-950
1 1/4-7	850-895	1150-1215
1 1/4-12	940-990	1275-1340
1 3/8-6	1125-1175	1525-1590
1 3/8-12	1280-1335	1735-1810
1 1/2-6	1500-1560	2035-2115
1 1/2-12	1685-1755	2285-2380

**IMPORTANT**

- *Follow these torque recommendations except when specified in text.*

## Complete Torque Chart

### Capscrews - Grade 8

**NOTE:**

- Grade 8 capscrews can be identified by six radial dashes on the head.
- For wheel torque requirements, refer to Wheels and Tires.
- Tighten U-bolts evenly and equally to have the same number of threads exposed on each end.



SIZE	FOOT POUNDS	NEWTON METERS
5/16-18	20-22	27-30
5/16-24	21-23	28-31
3/8-16	35-39	47-53
3/8-24	36-41	49-55
7/16-14	54-58	73-78
7/16-20	55-60	75-80
1/2-13	82-88	110-120
1/2-20	94-99	125-135
9/16-12	127-134	170-180
9/16-18	147-155	199-210
5/8-11	160-170	215-230
5/8-18	165-175	225-235
3/4-10	280-295	380-400
3/4-16	330-365	445-495
7/8-9	410-430	555-580
7/8-14	420-440	570-595
1-8	630-650	850-880
1-14	680-700	920-950
1 1/8-7	900-930	1220-1260
1 1/8-12	930-950	1260-1290
1 1/4-7	1250-1300	1695-1760
1 1/4-12	1280-1320	1735-1790

### IMPORTANT

- Follow these torque recommendations except when specified in text.

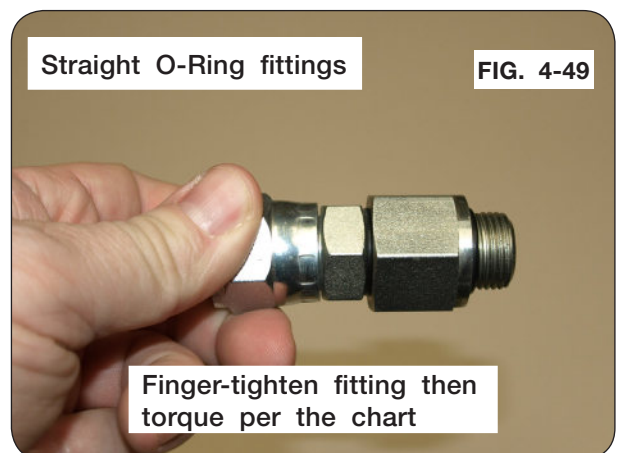
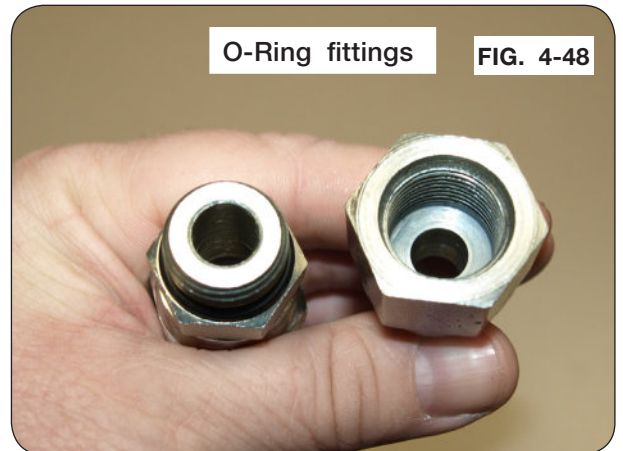
## Hydraulic Fittings - Torque and Installation

### Tightening O-Ring Fittings

1. Inspect components for damage or contamination. Do not connect any other type of fitting to an O-ring fitting.
2. For adjustable fittings, insure the jam nut and washer are fully backed up.
3. Lubricate the O-ring and threads on the fitting.
4. Turn the fitting into the port until it is finger tight.
5. For adjustable fittings, set in the desired position.
6. Using a wrench, torque the fitting to the value in the below table. For adjustable fittings the jam nut will be tightened.

**NOTE:** Never use a power tool to install a fitting.

Dash Size	Thread Size	Straight Stud Torque (Ft-Lbs)	Adjustable Stud Torque (Ft-Lbs)
-5	1/2-20	14-19	10-14
-6	9/16-18	18-24	12-16
-8	3/4-16	27-43	20-30
-10	7/8-14	36-48	30-36
-12	1-1/16-12	65-75	44-54
-14	1-3/16-12	75-99	53-70
-16	1-5/16-12	85-123	59-80
-20	1-5/8"-12	115-161	75-100
-24	1-7/8"-12	125-170	105-125

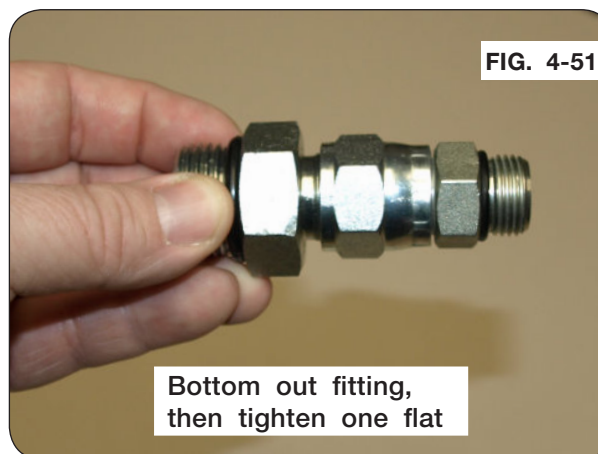
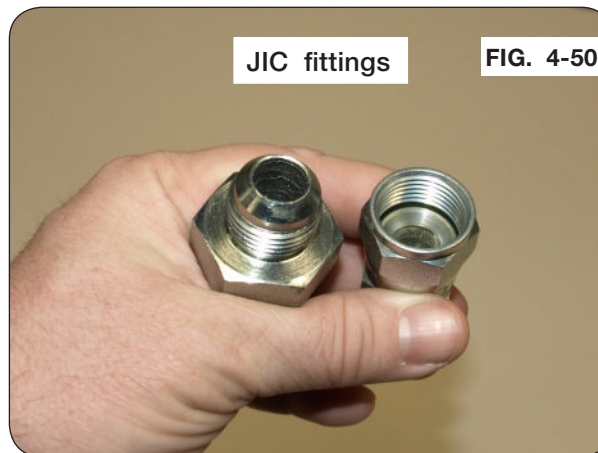


## Hydraulic Fittings - Torque and Installation

### Tightening JIC Fittings

1. Inspect all components for damage or contamination. Do not connect any other type of fitting to a JIC fitting.
2. Lubricate the threads.
3. Turn the fitting into the port until it bottoms out.
4. Use one wrench on the fixed hex on the hose to prevent twisting and a second on the swivel. Tighten the fitting another 60 degrees (or one flat)

**NOTE:** Never use a power tool to install a fitting



## **Section V Parts**

**Please visit [www.unverferth.com/parts/](http://www.unverferth.com/parts/) for the most current parts listing.**

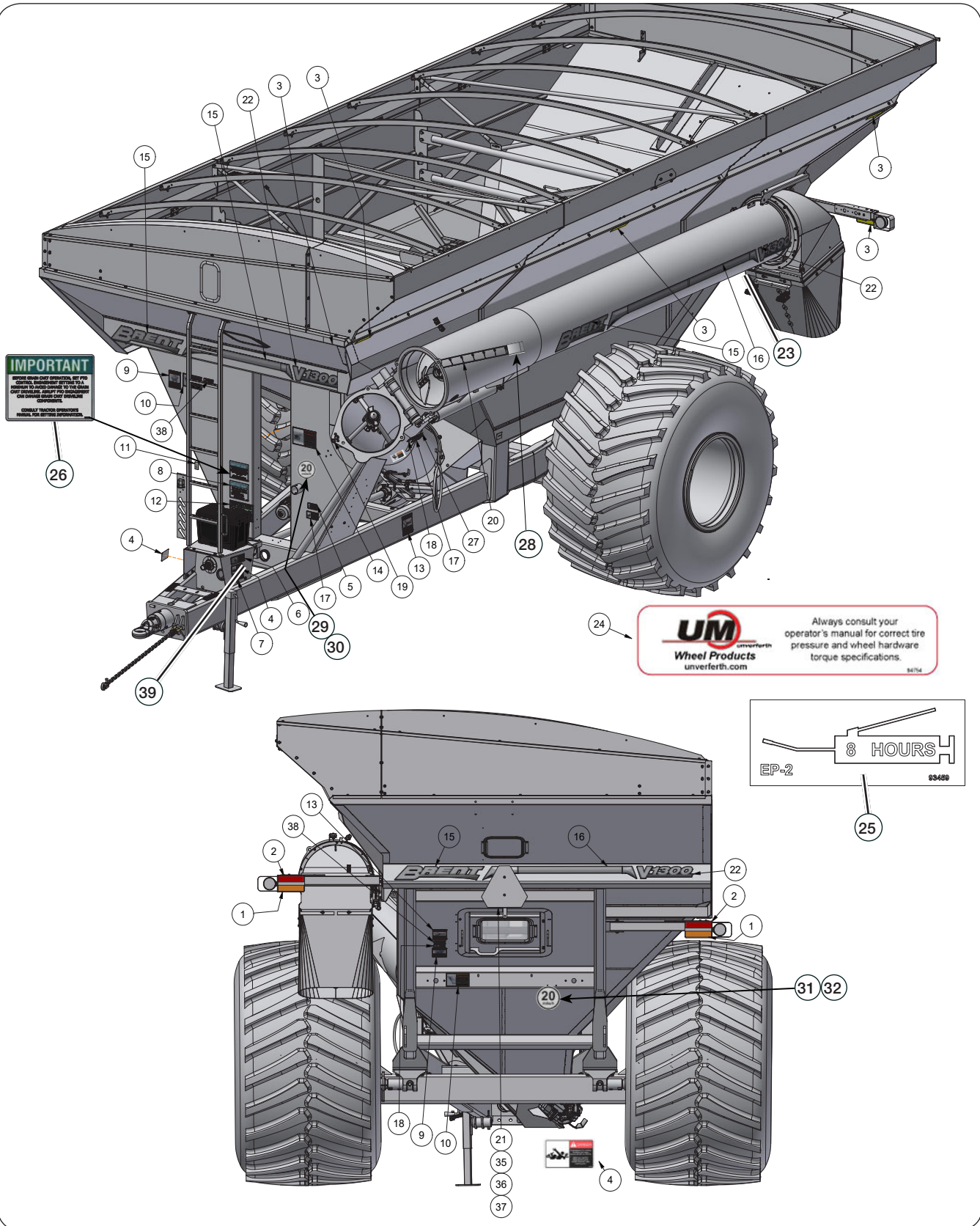
Decals .....	5-2
Final Assembly .....	5-4
Hopper Cross Brace Components .....	5-6
Clean Out Door Assembly .....	5-7
Flow Door Seals .....	5-8
Directional Spout .....	5-10
Wheel Well Cover Kit (V1300 Only) .....	5-14
Wheel Well Cover Kit (V1500 Only) .....	5-15
Rear Ladder Components .....	5-16
Rear Access Door Components .....	5-17
Sideboards .....	5-18
Single Wheel Axle (V1300 Only) .....	5-20
Single Wheel Axle (V1500 Only) .....	5-22
Track Axle (V1300 Only) .....	5-24
Track Axle (V1500 Only) .....	5-25
Driveline Components .....	5-26
Driveline U-Joint Assembly - For SN B45970100 & Higher .....	5-28
Driveline U-Joint Assembly - For SN B45970099 & Lower .....	5-29
Single Wheels and Tires .....	5-30
Touch Up Paint .....	5-30
Upper Auger Components .....	5-32
Lower Auger Components .....	5-34
PTO Cut Out Clutch Components (Benzi America) .....	5-36
PTO Components (Benzi America) .....	5-37
45 Degree Gearbox .....	5-38
Cylinders .....	5-40
Hydraulics .....	5-42
EOH Tractor Hydraulic Components (Optional) .....	5-45
EOH Valve Assembly Components (4 Spool) (Optional) .....	5-46
Electrical .....	5-48
Weather Guard Tarp .....	5-50
Video System Option .....	5-53
Hydraulic Jack- Kit #294143B (Optional) .....	5-54

FOR SCALE, TRACK, UHARVEST, HYDRAULIC DRIVE, ELECTRIC TARP, AND / OR WATER DELIVERY SYSTEM INFORMATION, PLEASE REFER TO THE INDIVIDUAL MANUALS.



Decals

Please visit [www.unverferth.com/parts/](http://www.unverferth.com/parts/) for the most current parts listing.



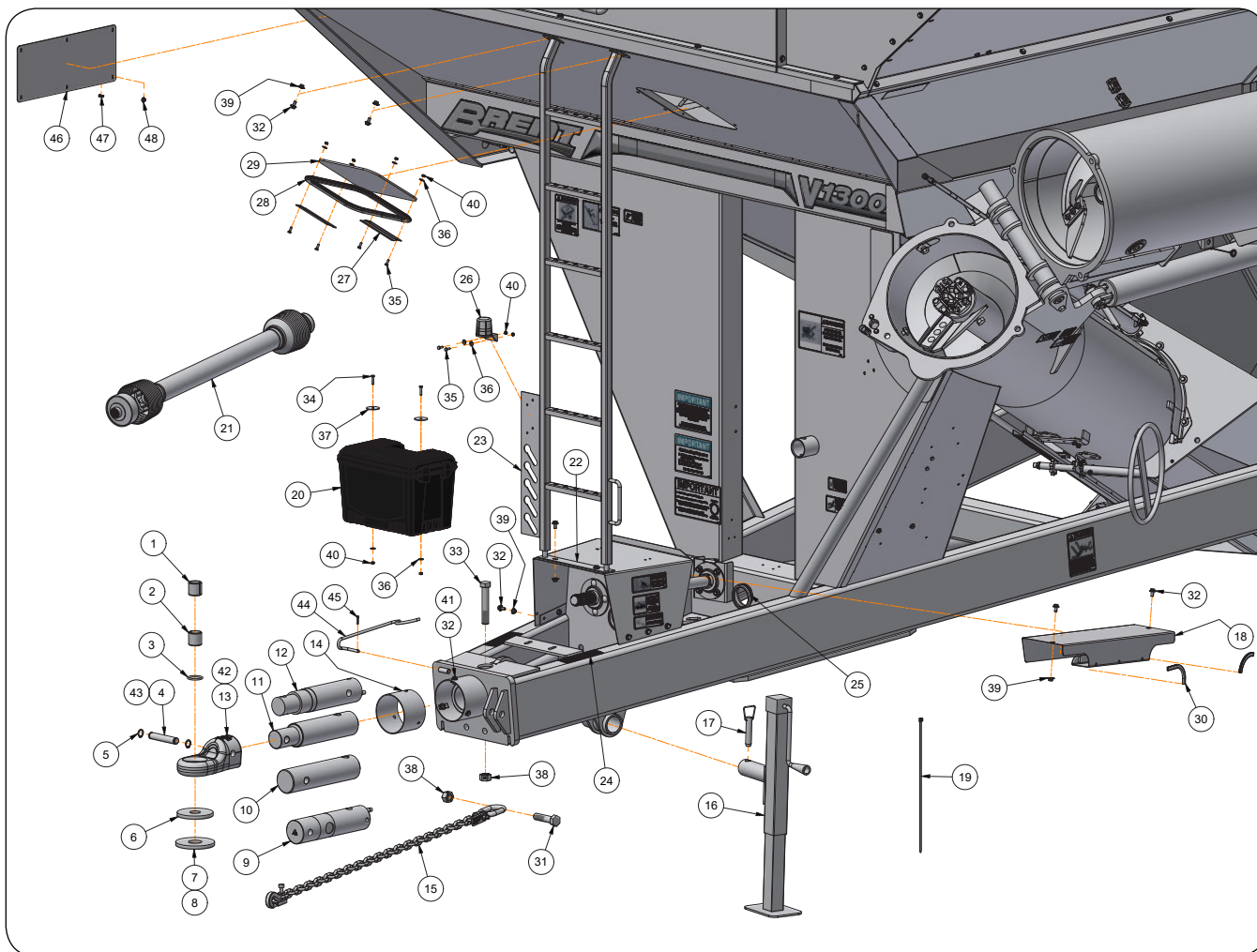
**Decals**

**Please visit [www.unverferth.com/parts/](http://www.unverferth.com/parts/) for the most current parts listing.**

ITEM	PART NUMBER	DESCRIPTION	QTY.	NOTES
1	9003125	Fluorescent Strip	3	2 x 9"
2	9003126	Red Reflector	3	2 x 9"
3	9003127	Amber Reflector	8	2 x 9"
4	95046	Decal, DANGER "Drive Shaft Entanglement"	3	
5	97961	Decal, WARNING "Read & Understand"	1	
6	94094	Decal, WARNING "Tongue Drop"	1	
7	97575	Decal, CAUTION "Transport Chain"	1	
8	9004966	Decal, Cart Loading Sequence	1	
9	9003478	Decal, DANGER "Just For Kids"	2	
10	9003476	Decal, WARNING "No Riders"	2	
11	91605	Decal, FEMA	1	
12	9003477	Decal, IMPORTANT "Flow Control Gate"	1	
13	9003475	Decal, WARNING "PTO Cut & Crush"	3	
14	9003474	Decal, DANGER "Electrical Lines"	1	
15	9006360	Decal, Brent Logo - 5.5 x 43	5	
16	9006361	Decal, Stripe - 2.73 x 36.50	13	
17	95445	Decal, WARNING "High-Pressure"	2	
18	95839	Decal, WARNING "Pinch Point"	3	
19	297599	Decal, Reflective Yellow Tape	1	
20	92563	Decal, Flow Control 3" x 38"	1	
21	TA510514	SMV Sign	1	Use Items 35, 36, and 37
22	9007877	Decal, V1300	5	
	9007878	Decal, V1500		
23	TA1-906109-0	Decal, WARNING "Moving Parts"	2	
24	94754	Decal, UM Wheel Systems	1	
25	93459	Decal, Grease Every 8 Hours	1	
26	9008151	Decal, IMPORTANT "PTO Engagement"	1	
27	9008447	Decal, IMPORTANT "Grease U-Joint Bearing"	1	
28	9008908	Decal, Max Flow	1	
29	9008715	Decal, Front SIS 20 MPH	1	
30	9008721	Decal, Front SIS 30 KPH	1	
31	9008714	Decal, Rear SIS 20 MPH	1	Use Items 33, 34 and 35
32	9008720	Decal, Rear SIS 30 KPH	1	
33	276987B	SIS Decal Mounting Bracket =Black=	1	Not Shown
34	97420	Flange Screw 1/4"-20UNC x 3/4" Grade 5	2	
35	97189	Hex Nut 1/4"-20UNC	6	
36	9390-005	Capscrew 1/4"-20UNC x 1" Grade 5	4	
37	9405-064	Flat Washer 1/4"	2	
38	95008	Decal, CAUTION "Slippery Surface"	2	
39	9009866	Decal, Hose Legend	1	

**Final Assembly**

Please visit [www.unverferth.com/parts/](http://www.unverferth.com/parts/) for the most current parts listing.



ITEM	PART NUMBER	DESCRIPTION	QTY.	NOTES
	271887B	CAT 5 Hitch Conversion Kit w/Scales	1	Includes Items 5, 8, 9, 42 & 43
	271893B	CAT 5 Hitch Conversion Kit w/out Scales	1	Includes Items 5, 8, 10, 42 & 43
1	9001917	Split Tension Bushing 2" OD x 1 1/2" ID x 2"	1	
2	9002130	Split Tension Bushing 2" OD x 1 3/4" ID x 2"	1	
3	9005259	O-Ring 1.975" Dia x .210"	1	
4	282876	Pin, 1" Dia x 5 5/8" CAT 4	1	
5	91192	Retaining Ring 1"	2	
6	281663	Wear Shoe, CAT 3	1	Optional
7	281898	Wear Shoe, CAT 4	1	Standard
8	281899	Wear Shoe, CAT 5	1	Optional
9	9008119	Hitch Load Bar (CAT 5 W/ Scales)	1	
10	271894	Hitch Bar (CAT 5 W/O Scales)	1	
11	284780	Hitch Bar (CAT 4W/O Scales)	1	
12	9004910	Hitch Load Bar (CAT 4 W/ Scales)	1	
13	282875B	Hitch, Cast - CAT 4 (Black)	1	
14	271891B	Shield Tube =Black=	1	
15	9003278	Transport Chain 20,000 Lb.	1	

**Final Assembly**

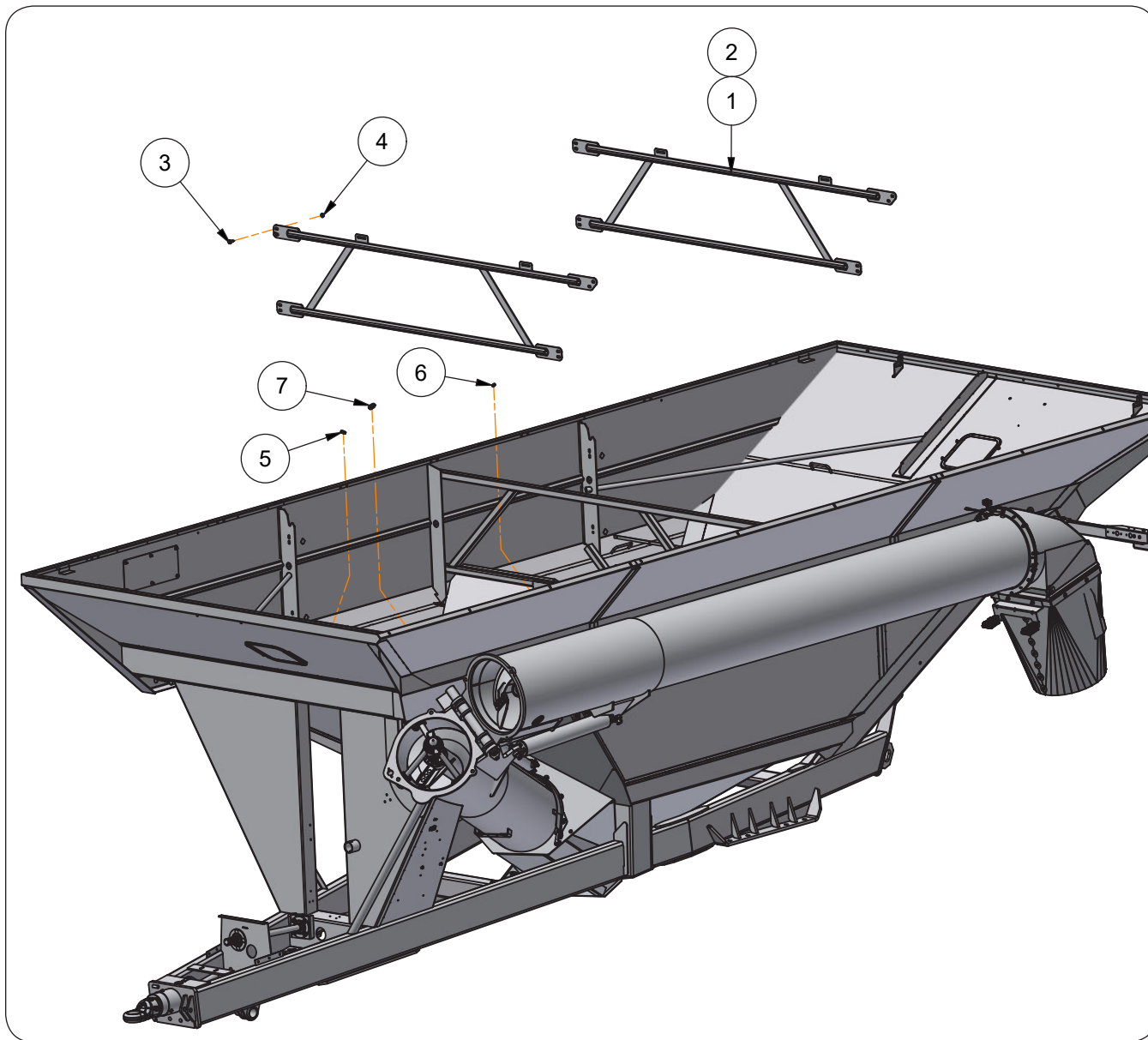
**Please visit [www.unverferth.com/parts/](http://www.unverferth.com/parts/) for the most current parts listing.**

ITEM	PART NUMBER	DESCRIPTION	QTY.	NOTES
16	9007178	Jack	1	
17	9004171	Jack Pin, 7/8" x 3 1/2"	1	
18	288381B	Driveshaft Cover Plate =Black=	1	
19	9000140	Cable Tie 21 1/2"	5	
20	9005850	Storage Box	1	
21	9009527	PTO Assembly	1	Benzi PTO Assembly
22	280603B	Lower Ladder Weldment =Black=	1	
23	288378B	Ladder Weldment =Black=	1	
24	9001498	Rubber Pad	2	
25	9006780	Grommet 3 1/2" OD x 3" ID x 1/4"	1	
26	9001968	Connector Holder	1	
27	250461B	Window Bracket =Black=	2	
28	271952	Window Moulding	3	
29	9002544	Window, 1/4" x 12 5/8" x 12 5/8"	1	
30	9000787	Trim Edge	----	Order Per Foot
31	91299-191	Capscrew 1"-8UNC x 4" Grade 8	1	
32	95585	Flange Screw 3/8"-16UNC x 3/4" Grade 5	12	
33	91299-195	Capscrew 1"-8UNC x 6" Grade 8	1	
34	9390-006	Capscrew 1/4"-20UNC x 1 1/4" Grade 5	2	
35	9390-003	Capscrew 1/4"-20UNC x 3/4" Grade 5	2	
36	9405-064	Flat Washer 1/4" USS	8	
37	94763	Fender Washer 2" OD x 5/16" ID	2	
38	92199	Lock Nut 1"-8UNC	2	
39	91263	Flange Nut 3/8"-16UNC	12	
40	9936	Lock Nut 1/4"-20UNC	8	
41	9005376	U-Nut 3/8"-16UNC	3	
42	282329B	Cast Hitch - CAT 5 Load Bar (Black)	1	
43	281691	Pin 1" Dia. x 7 3/8 CAT 5	1	
44	297558	Driveline Storage Rod	1	
45	9391-023	Cotter Pin, 1" x 1/8" Dia.	1	
46	295491G	Scale Display Cover Plate =Green=	1	
	295491R	Scale Display Cover Plate =Red=		
	295491BM	Scale Display Cover Plate =Black Metallic=		
47	9003829	Hex Screw 1/4"-20UNC x 3/4" Full Thread	6	
48	97189	Flange Nut 1/4"-20UNC	6	



**Hopper Cross Brace Components**

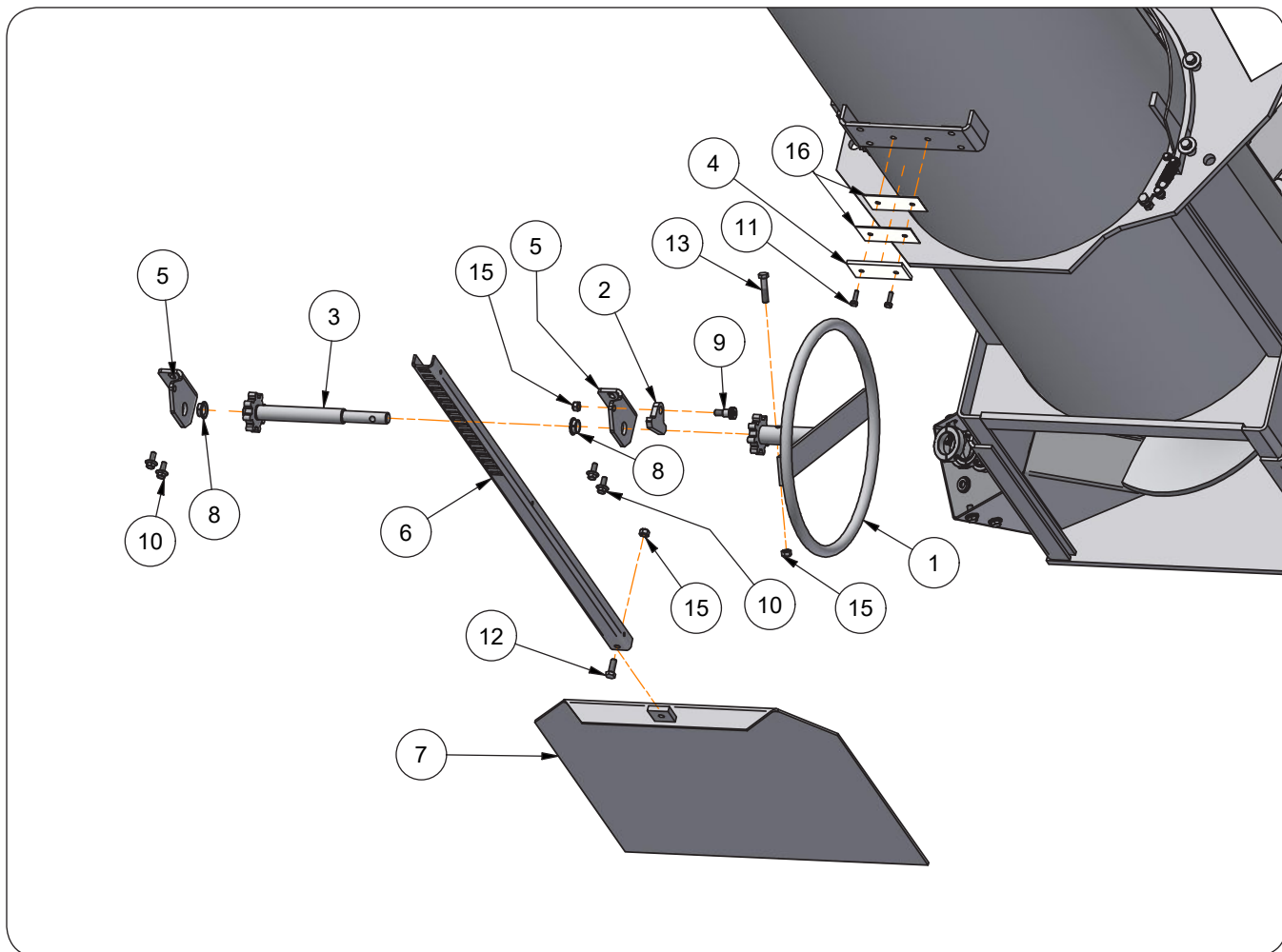
Please visit [www.unverferth.com/parts/](http://www.unverferth.com/parts/) for the most current parts listing.



ITEM	PART NO.	DESCRIPTION	QTY	NOTES
1	297772B	Cross Brace Weldment =Black=	2	For V1300
2	297833B			For V1500
3	9003397	Flange Nut 1/2"-13UNC	16	
4	91266	Flange Screw 1/2"-13UNC x 1 1/2" Grade 5	16	
5	9009602	Grommet 1 3/8" OD x 3/4" ID x 7/16"	1	
6	9007987	Grommet 1" OD x 5/16" ID x 7/16"	1	
7	9009934	Plug 1 7/8" Dia.	1	

**Cleanout Door Assembly**

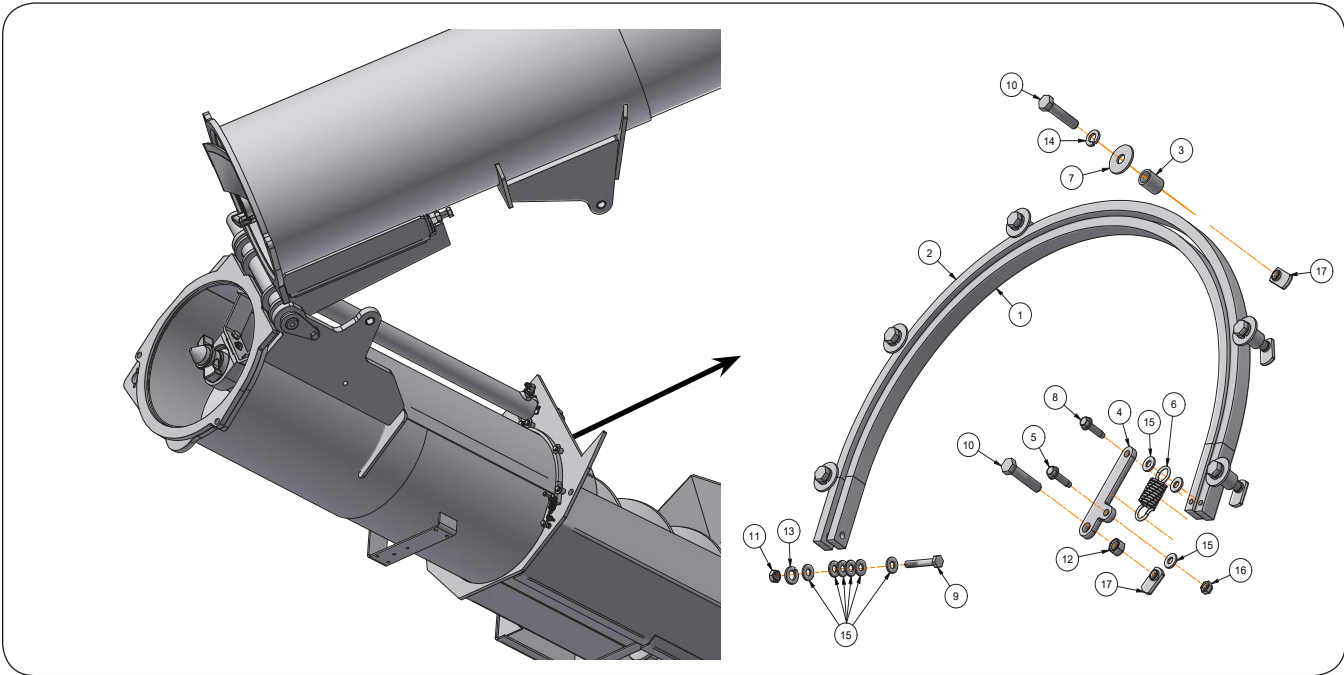
Please visit [www.unverferth.com/parts/](http://www.unverferth.com/parts/) for the most current parts listing.



ITEM	PART NUMBER	DESCRIPTION	QTY.	NOTES
1	268312B	Door Lift/Wheel Weldment =Black=	1	
2	268313B	Plate - Lock =Black=	1	
3	268901	Door Lift/Shaft Weldment	1	
4	286801	Pad - Wear	1	
5	286802B	Plate - Door Lift =Black=	2	
6	288296B	Plate - Door Rack =Black=	1	
7	288714B	Door Weldment =Black=	1	
8	9003411	Bushing-Split	2	
9	9006181	Shoulder Bolt-1/2" Dia. x 1/2"	1	
10	91256	Flange Screw 5/16"-18UNC x 3/4"	4	
11	9390-004	Capscrew 1/4"-20UNC x 7/8"	2	
12	9390-055	Capscrew 3/8"-16UNC x 1"	1	
13	9390-058	Capscrew 3/8"-16UNC x 1 3/4"	1	
14	9404-017	Lock Washer 1/4"	2	
15	9928	Top Locknut 3/8"-16UNC	2	
16	291087B	Shim =Black=	2	

**Flow Door Seals**

**Please visit [www.unverferth.com/parts/](http://www.unverferth.com/parts/) for the most current parts listing.**



ITEM	PART NUMBER	DESCRIPTION	QTY.	NOTES
1	292294	Seal - Poly	1	
2	287073	Seal - Poly	1	
3	281257G	Spacer Bushing =Green=	6	
	281257R	Spacer Bushing =Red=		
4	288606	Spring Bracket	1	
5	9004355	Screw, 1/4-20UNC x 1 (Self-Threading)	2	
6	9004375	Spring	1	
7	9405-078	Flat Washer 3/8"	6	
8	9390-004	Capscrew, 1/4-20UNC x 7/8 Grade 5	1	
9	9390-008	Capscrew, 1/4-20UNC x 1 3/4 Grade 5	1	
10	9390-058	Capscrew, 3/8-16UNC x 1 3/4 Grade 5	7	
11	9394-002	Hex Nut, 1/4-20UNC Grade 5	1	
12	9394-006	Hex Nut, 3/8-16UNC Grade 5	1	
13	9404-017	Lock Washer, 1/4	1	
14	9404-021	Lock Washer, 3/8	6	
15	9405-062	Flat Washer 1/4	7	
16	9936	Lock Nut, 1/4-20UNC	1	
17	288113B	Pusher Plate	1	

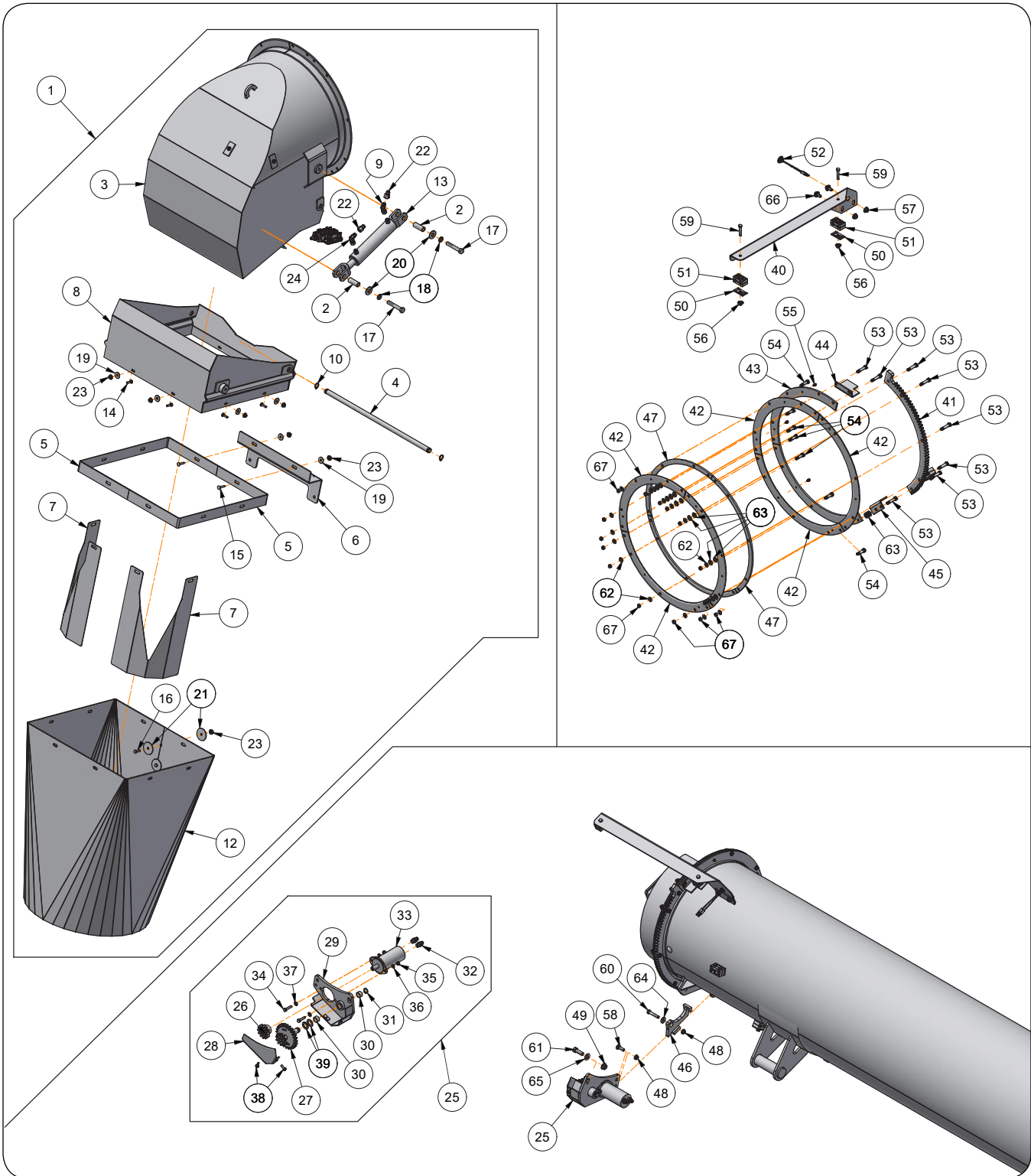


**Notes**

**Please visit [www.unverferth.com/parts/](http://www.unverferth.com/parts/) for the most current parts listing.**

### Directional Spout

Please visit [www.unverferth.com/parts/](http://www.unverferth.com/parts/) for the most current parts listing.



**Directional Spout**

**Please visit [www.unverferth.com/parts/](http://www.unverferth.com/parts/) for the most current parts listing.**

ITEM	PART NUMBER	DESCRIPTION	QTY.	NOTES
1	288946B	Spout Assembly =Black=	1	Includes Items 2-24
2	285290	Bushing-Sleeve 2.0625" Long	2	
3	288947B	Spout Weldment =Black=	1	
4	290993	Shaft-Pivot 3/4" Dia. x 25 5/16"	1	
5	292197B	Plate-Chute Strap =Black=	2	
6	292198B	Bracket-Light =Black=	1	
7	292292B	Plate, Chute Support =Black=	2	
8	292352B	Spout Weldment =Black=	1	
9	9001041	45° Elbow 9/16"-18 JIC Female x 9/16"-18 JIC Male	1	
10	9003810	Snap Ring 3/4"	2	
11	9008957	Light-Work, LED	2	
12	9008139	Rubber Hood	1	
13	9008152	Hydraulic Welded Cylinder 1 1/2" x 6"	1	
14	9388-003	Carriage Bolt 1/4"-20UNC x 1"	6	
15	9388-004	Carriage Bolt 1/4"-20UNC x 1 1/4"	2	
16	9390-005	Capscrew 1/4"-20UNC x 1"	8	
17	9390-107	Capscrew 1/2"-13UNC x 3 Grade 5	2	
18	9404-025	Lock Washer 1/2"	2	
19	9405-066	Flat Washer 1/4" (Fender Washer)	8	
20	9405-088	Flat Washer 1/2" USS	2	
21	94763	Fender Washer 5/16" ID	16	
22	95193	Adapter 9/16"-18 JIC Female x 9/16"-18 JIC Male w/Restrictor	2	
23	97189	Hex Nut/Large Flange 1/4"-20UNC	16	
24	9876	90° Elbow 9/16"-18 JIC Female x 9/16"-18 JIC Male	1	
25	288188B	Spout Motor Assembly =Black=	1	Includes Items 26 - 39
26	272840	Gear Weldment	1	
27	272844	Gear & Shaft Weldment	1	
28	288384B	Panel-Cover =Black=	1	
29	288385B	Spur Gear Mount Weldment =Black=	1	
30	9003809	Self-Lubricating Bushing	2	
31	9003810	Snap Ring 3/4"	1	
32	9004393	Adapter 9/16"-18 JIC Female x 9/16"-18 JIC Male w/Restrictor	2	
33	9010071	Motor-Hydraulic 4.90 CID, 1 1/4" Dia. Shaft	1	Bolt Together Item
	9007626	Motor-Hydraulic 3.07 CID, 1" Dia. Shaft	1	Single Piece Item
	9008974	Seal Kit	-	Used With #9007626
34	9390-031	Capscrew 5/16"-18UNC x 1 1/4"	17	
35	9394-004	Hex Nut 5/16"-18UNC	6	
36	9404-019	Lock Washer 5/16"	6	
37	9405-068	Flat Washer 5/16" SAE	2	
38	97420	Flange Screw 1/4"-20UNC x 3/4" Grade 5	2	

(Continued on next page)

**Directional Spout (continued)**

**Please visit [www.unverferth.com/parts/](http://www.unverferth.com/parts/) for the most current parts listing.**

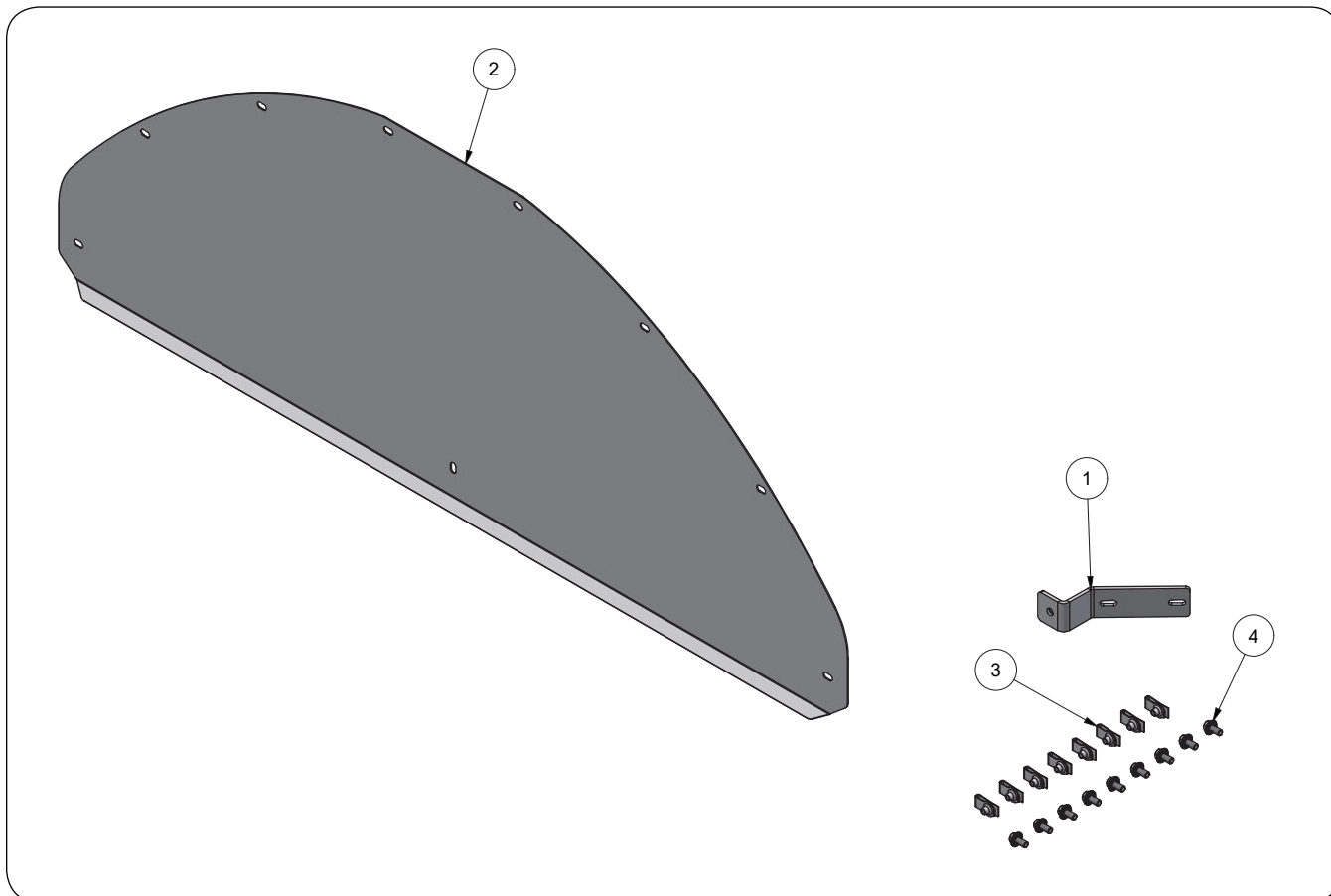
ITEM	PART NUMBER	DESCRIPTION	QTY.	NOTES
39	TA500309	Washer/Bushing 1 1/4" OD x 3/4" ID	2	
40	288383B	Hose Bracket Plate =Black=	1	
41	272719	Gear Rack	1	
42	272748	Pad-Pivot, 22 7/8" ID x 1/8"	6	
43	272842B	Plate-Pivot, Spout =Black=	2	
44	272855B	Stop Plate =Black=	1	
45	290884B	Stop Plate =Black=	1	
46	291327B	Stop Weldment =Black=	1	
47	291344B	Plate-Pivot, Spacer 24 3/16" ID x 1/4"	3	
48	9003396	Locknut/Top 3/8"-16UNC (Automation Locknut)	2	
49	9003397	Locking Flange Nut 1/2"-13UNC	1	
50	9003814	Clamp Top Plate	12	
51	9003816	Poly Clamp Pair (0.55)	16	
52	9006107	Amber Light Led 3/4" Dia.	2	
53	9007837	Shoulder Bolt 3/8" Dia. x 1 1/4", Socket Head, 5/16"-18UNC	8	
54	9007838	Shoulder Bolt 3/8" Dia. x 7/8", Socket Head, 5/16"-18UNC	7	
55	91160	Grease Zerk	4	
56	91257	Hex Nut/Large Flange 5/16"-18UNC	4	
57	91263	Hex Nut/Large Flange 3/8"-16UNC	2	
58	9388-052	Carriage Bolt 3/8"-16UNC x 1 1/4" Grade 5	1	
59	9390-033	Capscrew 5/16"-18UNC x 1 3/4" Grade 5	2	
60	9390-059	Capscrew 3/8"-16UNC x 2"	1	
61	9390-101	Capscrew 1/2"-13UNC x 1 1/2" Grade 5	1	
62	9405-064	Flat Washer 1/4" USS	17	
63	9405-074	Flat Washer 3/8" SAE	18	
64	9405-076	Flat Washer 3/8" USS	1	
65	9405-086	Flat Washer 1/2" SAE	1	
66	95585	Capscrew/Large Flange 3/8"-16UNC x 3/4" Grade 5	7	
67	9807	Locknut 5/16"-18UNC	19	

**Notes**

**Please visit [www.unverferth.com/parts/](http://www.unverferth.com/parts/) for the most current parts listing.**

**Wheel Well Cover Kit - Model V1500**

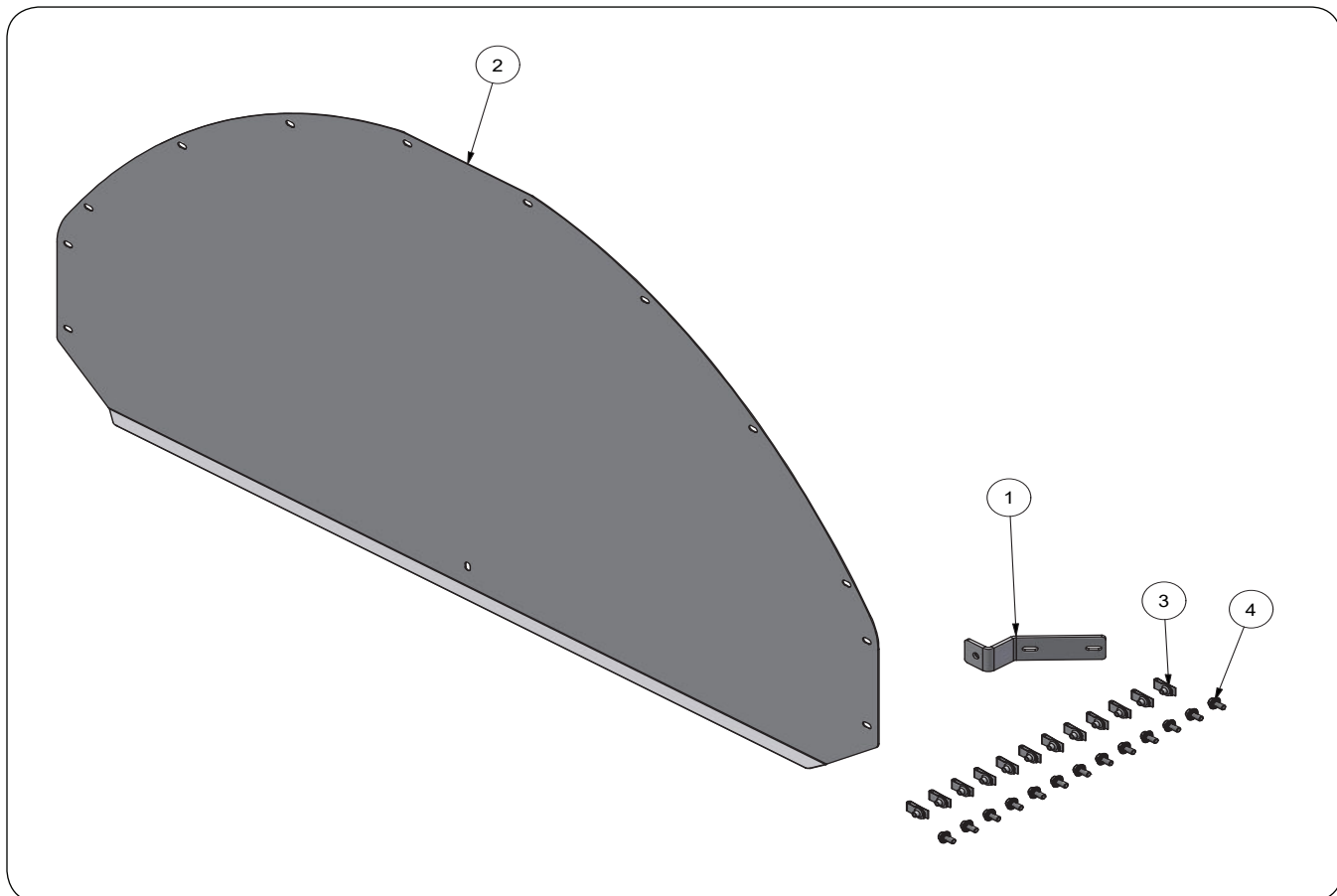
**Please visit [www.unverferth.com/parts/](http://www.unverferth.com/parts/) for the most current parts listing.**



ITEM	PART NO.	DESCRIPTION	QTY	NOTES
	294784G	Wheel Well Cover Kit (Green)	2	Includes Items 1 - 4
	294784R	Wheel Well Cover Kit (Red)		
	294784BM	Wheel Well Cover Kit (Black Metallic)		
1	287691B	Plate Weldment =Black=	2	
2	294785G	Cover Panel =Green=	2	
	294785R	Cover Panel =Red=		
	294785BM	Cover Panel =Black Metallic=		
3	9005376	U-Nut 3/8"-16UNC	16	
4	95585	Large Flange Capscrew 3/8"-16UNC x 3/4" Grade 5	18	

**Wheel Well Cover Kit - Model V1300**

**Please visit [www.unverferth.com/parts/](http://www.unverferth.com/parts/) for the most current parts listing.**

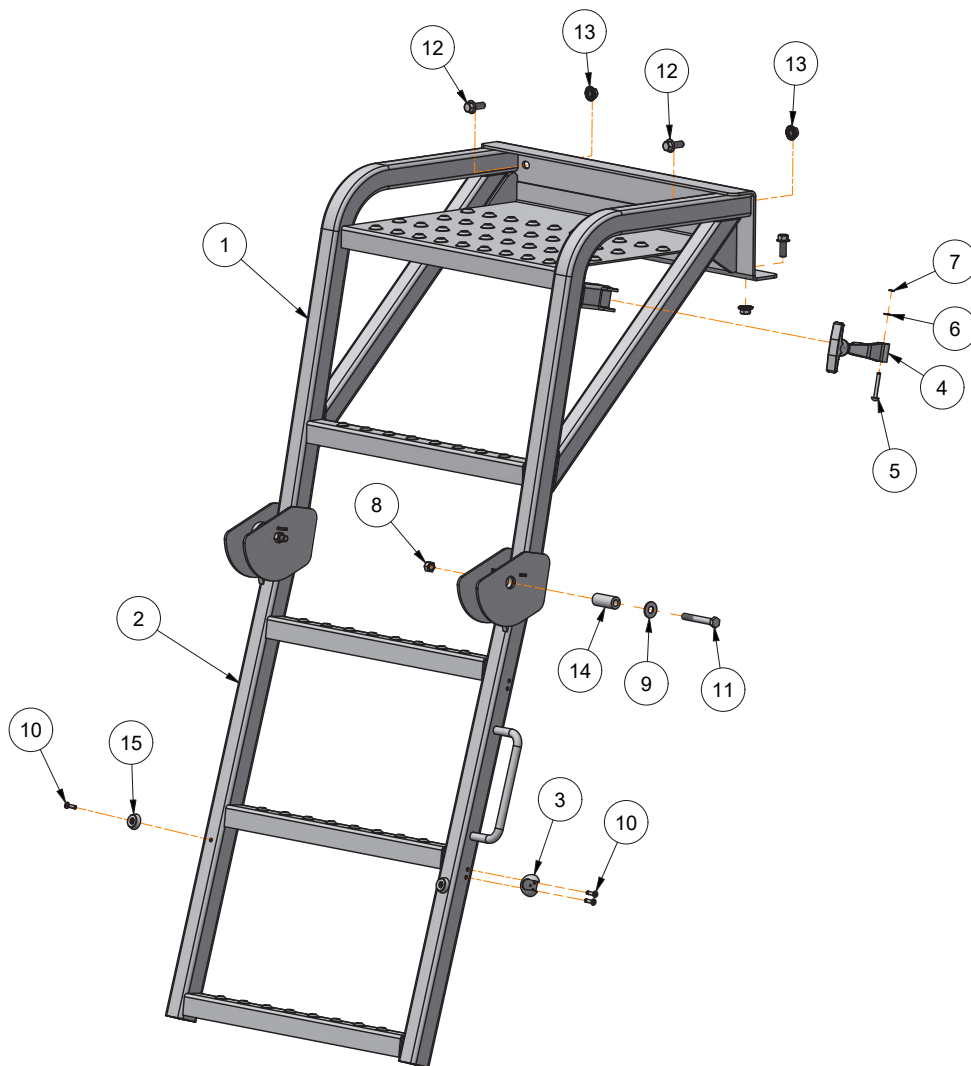


ITEM	PART NO.	DESCRIPTION	QTY	NOTES
	288203G	Wheel Well Cover Kit (Green)	2	Includes Items 1 - 4
	288203R	Wheel Well Cover Kit (Red)		
	288203BM	Wheel Well Cover Kit (Black Metallic)		
1	287691B	Plate Weldment =Black=	2	
2	288128G	Cover Panel =Green=	2	
	288128R	Cover Panel =Red=		
	288128BM	Cover Panel =Black Metallic=		
3	9005376	U-Nut 3/8"-16UNC	24	
4	95585	Large Flange Capscrew 3/8"-16UNC x 3/4" Grade 5	26	



Rear Ladder Components

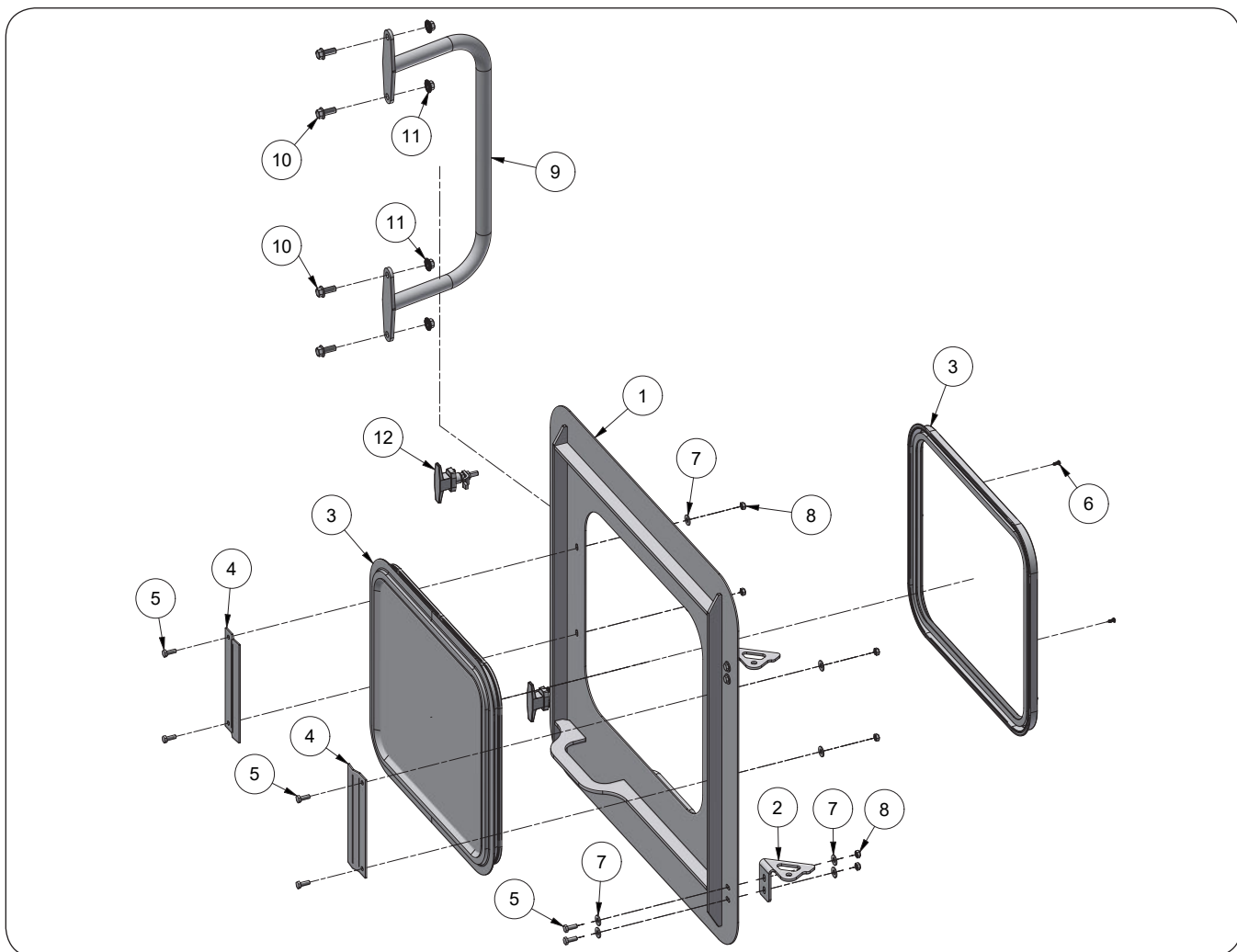
Please visit [www.unverferth.com/parts/](http://www.unverferth.com/parts/) for the most current parts listing.



ITEM	PART NO.	DESCRIPTION	QTY	NOTES
1	297608B	Upper Ladder Weldment =Black=	1	
2	296429B	Lower Ladder Weldment =Black=	1	
3	900059	Draw Latch Keeper	1	
4	900060	Draw Latch Handle	1	
5	900066	Pin 3/16" x 1 1/2"	1	
6	900067	Washer 1/2"	1	
7	900068	E-Ring	1	
8	9928	Lock Nut 3/8-16UNC"	2	
9	9405-076	Flat Washer 3/8" USS	2	
10	TA0-908386-0	3/16" Stainless Rivet	4	
11	9390-062	Capscrew 3/8"-16UNC x 2 3/4" Grade 5	2	
12	91262	Flange Screw 3/8"-16UNC x 1" Grade 5	4	
13	91263	Flange Nut 3/8"-16UNC	4	
14	295137	Pivot Bushing	2	
15	9003850	Bumper	2	

**Rear Access Door Components**

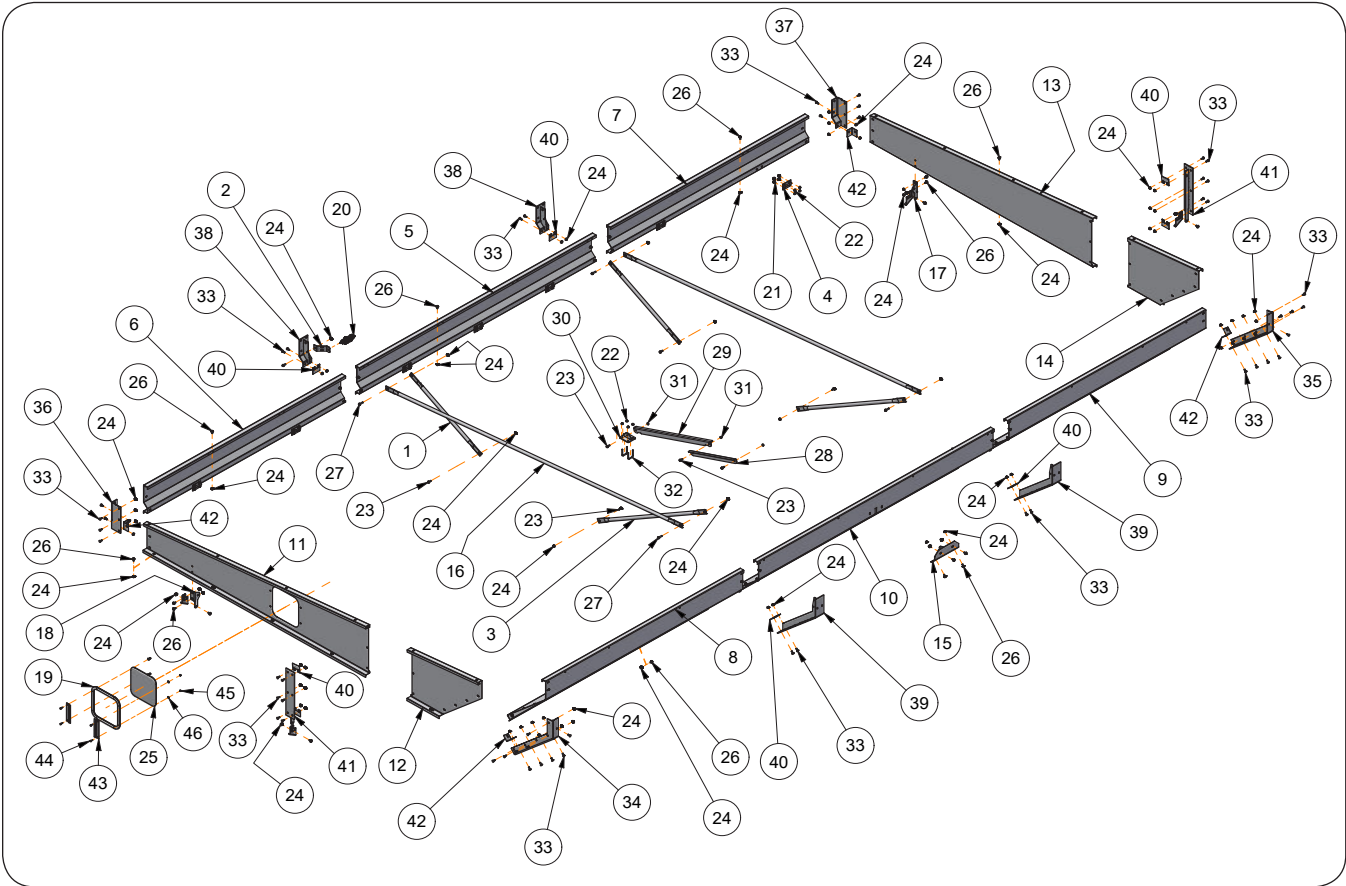
Please visit [www.unverferth.com/parts/](http://www.unverferth.com/parts/) for the most current parts listing.



ITEM	PART NO.	DESCRIPTION	QTY	NOTES
1	256527R	Rear Access Door Weldment =Red=	1	
	256527G	Rear Access Door Weldment =Green=		
	256527BM	Rear Access Door Weldment =Black Metallic=		
2	256670	Rear Access Door Hinge	2	
3	9008680	Window and Trim Assembly	1	
4	294121B	Window Bracket =Black=	2	
5	9390-003	Capscrew 1/4"-20UNC x 3/4" Grade 5	8	
6	9008933	Phillips Head Screw #8-18 x 1/2"	10	
7	9405-064	Flat Washer 1/4"USS	8	
8	9936	Locknut 1/4"-20UNC	8	
9	296534B	Handle Weldment =Black=	1	
10	91262	Flange Screw 3/8"-16UNC x 1" Grade 5	4	
11	91263	Flange Nut 3/8"-16UNC	4	
12	9009768	Draw Latch	2	

Sideboards

Please visit [www.unverferth.com/parts/](http://www.unverferth.com/parts/) for the most current parts listing.



# Brent V1300 / V1500 — Parts

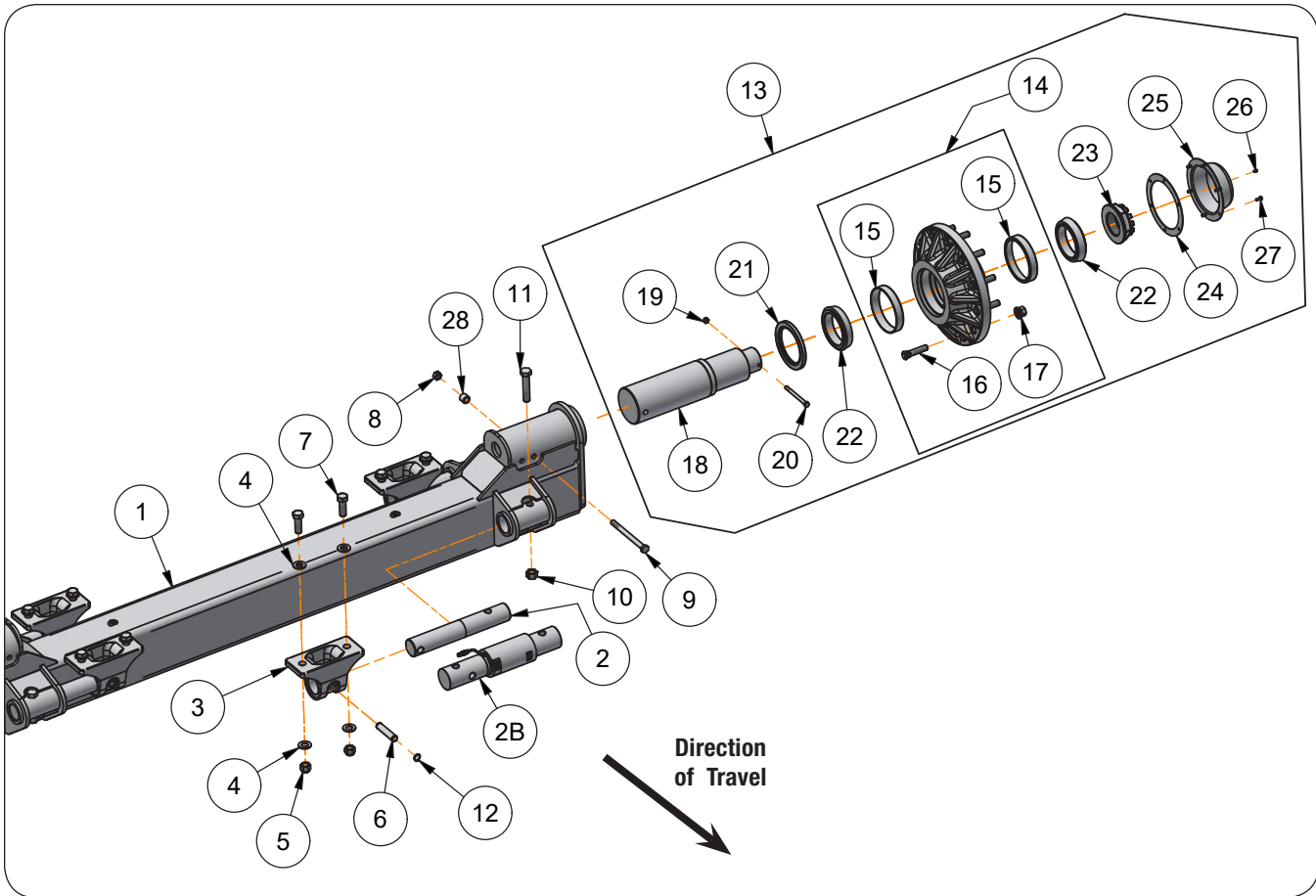
## Sideboards

Please visit [www.unverferth.com/parts/](http://www.unverferth.com/parts/) for the most current parts listing.

ITEM	PART NUMBER	DESCRIPTION	QTY.	NOTES
1	220032B	Tube, Angle Brace/Sideboard Support 39 7/8" =Black=	2	
2	271574B	Work Light Mount Plate =Black=	1	
3	287692B	Sideboard Brace Tube =Black=	2	For V1300
	288653B			For V1500
4	9004626	Hinge	14	
5	295674B	Sideboard, Center RH =Black=	1	
6	295673B	Sideboard, Front RH =Black=	1	
7	295695B	Sideboard, Rear RH =Black=	1	
8	295675B	Sideboard, Front LH =Black=	1	For V1300
	296378B			For V1500
9	295696B	Sideboard, Rear LH =Black=	1	For V1300
	296392B			For V1500
10	295676B	Sideboard, Center LH =Black=	1	For V1300
	296379B			For V1500
11	297652B	Large Sideboard Front =Black=	1	For V1300
	297653B			For V1500
12	295670B	Small Sideboard, Front =Black=	1	For V1300
	296373B			For V1500
13	295671B	Large Sideboard Rear =Black=	1	
14	295672B	Small Sideboard, Rear =Black=	1	For V1300
	296375B			For V1500
15	288355B	Brace Weldment =Black=	1	
16	288377B	Brace Tube 149 7/8" =Black=	2	For V1300
	288641B	Brace Tube 167 1/2" =Black=		For V1500
17	288427B	Hinge Plate =Black=	1	
18	288428B	Hinge Plate =Black=	1	
19	9001489	Window Molding	4.125	Order Per Foot
20	9008957	Work Light, LED	1	
21	91256	Flange Screw 5/16"-18UNC x 3/4"	56	
22	91257	Flange Nut 5/16"-18UNC	60	
23	91262	Flange Screw 3/8"-16UNC x 1"	8	
24	91263	Flange Nut 3/8"-16UNC	132	
25	9002544	Window, 1/4" x 12 5/8" x 12 5/8"	1	
26	95585	Flange Screw 3/8"-16UNC x 3/4"	46	
27	95785	Flange Screw 3/8"-16UNC x 1 1/2" Grade 5	4	
28	288693B	Brace Sideboard 24 1/4" =Black=	1	
29	288694B	Brace Sideboard 40 7/8" =Black=	1	
30	288698B	Brace Mount Weldment =Black=	1	
31	9003396	Locknut 3/8"-16UNC	3	
32	9002713	U-Bolt 5/16"-18UNC x 2 3/4" Grade 5	2	
33	9388-051	Carriage Bolt 3/8"-16UNC x 1" Grade 5	72	
34	295677B	Sideboard Corner Plate, LH Front =Black=	1	For V1300
	296380B			For V1500
35	295678B	Sideboard Corner Plate, LH Rear =Black=	1	For V1300
	296381B			For V1500
36	295679B	Sideboard Corner Plate, RH Front =Black=	1	
37	295680B	Sideboard Corner Plate, RH Rear =Black=	1	
38	295681B	Sideboard Bracket Weldment, RH =Black=	2	
39	295682B	Sideboard Bracket Weldment, LH =Black=	2	For V1300
	296385B			For V1500
40	295691B	Sideboard Cover Plate =Black=	8	
41	295697B	Sideboard Bracket Weldment Front/Rear =Black=	2	
42	295667B	Sideboard Cover Plate =Black=	4	
43	250461B	Window Bracket =Black=	2	
44	9390-003	Capscrew, 1/4"-20UNC x 3/4" Grade 5	4	
45	9936	Locknut, 1/4"-20UNC	4	
46	9405-064	Flat Washer 1/4"	4	

**Single Wheel Axle — For V1300 Only**

**Please visit [www.unverferth.com/parts/](http://www.unverferth.com/parts/) for the most current parts listing.**



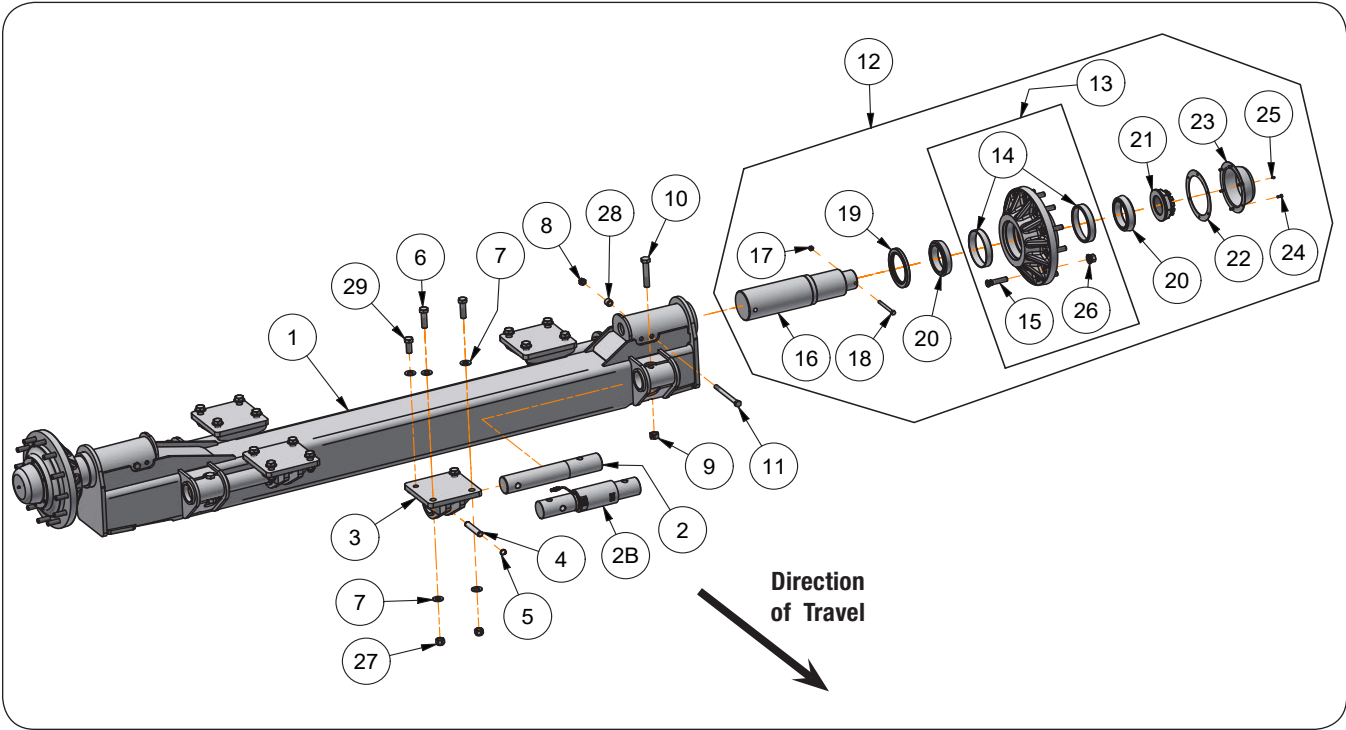
**Single Wheel Axle — For V1300 Only**

**Please visit [www.unverferth.com/parts/](http://www.unverferth.com/parts/) for the most current parts listing.**

ITEM	PART NUMBER	DESCRIPTION	QTY	NOTES
	288191B	Rigid Axle Assembly w/out Scales (Black)	1	Includes Items 1, 2 & 3 through 28
	288190B	Rigid Axle Assembly w/Scales (Black)		Includes Items 1 & 2B, 3 through 28
1	288223B	Axle Weldment =Black=	1	
2	268289	Hitch Bar W/O Scales	4	
2B	9004903	Hitch Bar W/ Scales	4	
3	283854B	Axle Mount Casting =Black=	4	
4	804685	Washer 2" OD x 1 1/16" ID	16	
5	9008441	Locknut 1"-14UNS Gr. 8	8	
6	250843	Axle Mount Pin	4	
7	91299-1456	Capscrew 1"-14UNS x 3" Grade 8	8	
8	9008442	Locknut 3/4"-10UNC	2	
9	91299-256	Capscrew 3/4"-10UNC x 9" Grade 8	2	
10	92199	Locknut 1"-8UNC	4	
11	9390-193	Capscrew 1"-8UNC x 5" Grade 5	4	
12	91192	Retaining Ring	8	
13	282310B	Hub and Spindle Assembly (Black)	2	Includes Items 14-27
14	282312B	Hub Assembly (Black)	2	Includes Items 15-17
15	9006996	Bearing Cup	4	
16	9007001	Stud Bolt	24	
17	97319	Flange Nut M22 x 1.5" Grade 10	24	
18	282311	Spindle	2	
19	94981	Lock Nut 1/2"-13UNC	2	
20	9007854	Capscrew 1/2"-13UNC x 5 3/4" Grade 5	2	
21	9007010	Seal, 200mm x 150mm x 15mm	2	
22	9007007	Bearing Cone	4	
23	282316	Spindle Nut	2	
24	282315	Hub Cap Gasket	2	
25	282314B	Hub Cap =Black=	2	
26	91160	Grease Fitting	2	
27	9390-028	Capscrew 5/16"-18UNC x 3/4" Grade 5	24	
28	283895B	Spacer Bushing =Black=	2	

**Single Wheel Axle — For V1500 Only**

**Please visit [www.unverferth.com/parts/](http://www.unverferth.com/parts/) for the most current parts listing.**





**Single Wheel Axle — For V1500 Only**

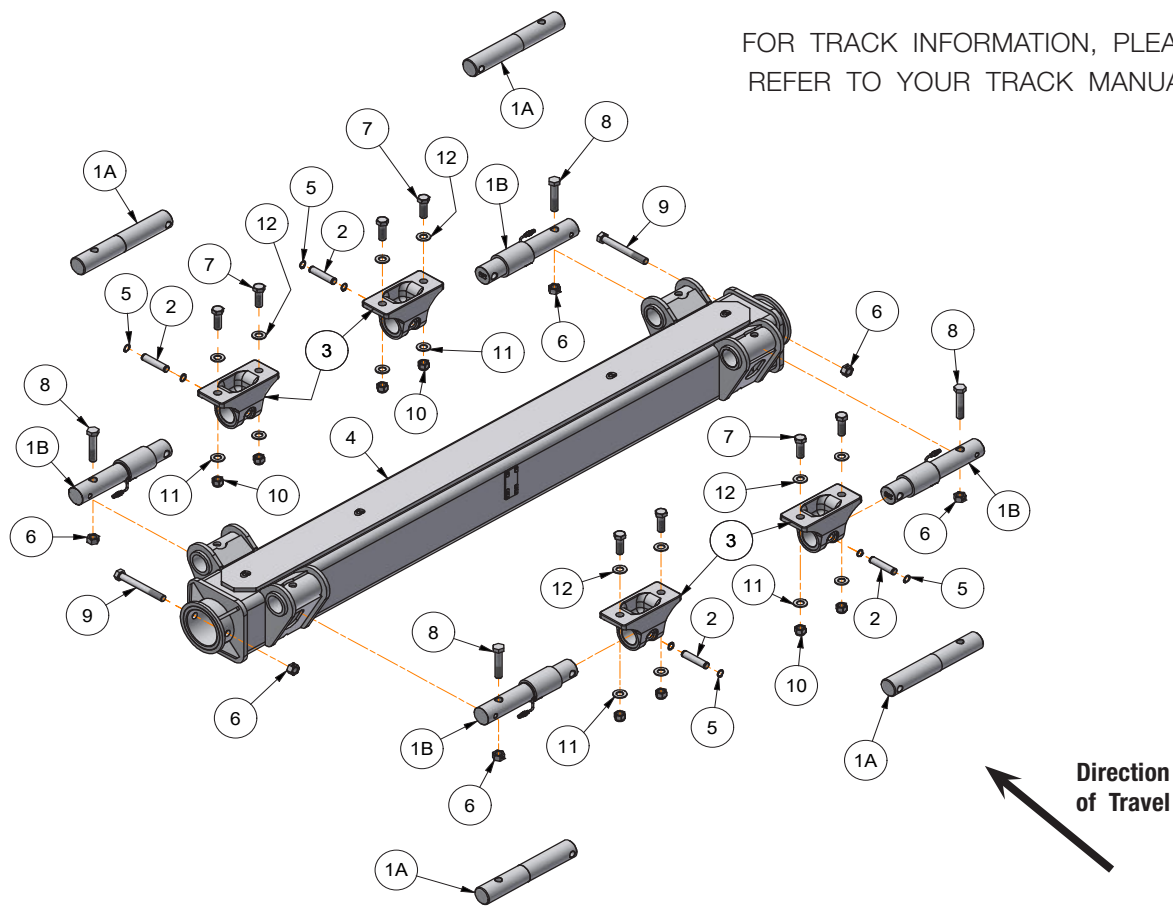
**Please visit [www.unverferth.com/parts/](http://www.unverferth.com/parts/) for the most current parts listing.**

ITEM	PART NUMBER	DESCRIPTION	QTY	NOTES
	294593B	Rigid Axle Assembly w/out Scales =Black=	1	Includes Items 1, 2 & 3 through 29
	294592B	Rigid Axle Assembly w/Scales =Black=		Includes Items 1 & 2B through 29
1	294594B	Axle Weldment =Black=	1	
2	282745	Hitch Bar For Units w/o Scales	4	
2B	9005811	Weigh Bar For Units w/ Scales	4	
3	288596B	Axle Mount Weldment =Black=	4	
4	282876	Axle Weldment Pin	4	
5	91192	Retaining Ring 1"	8	
6	91299-1458	Capscrew 1"-14UNS x 3 1/2" Grade 8	8	
7	804685	Washer 2"OD x 1 1/16" ID	24	
8	9008442	Locknut 3/4"-10 UNC Grade 8	2	
9	92199	Locknut 1"-8UNC	4	
10	9390-194	Capscrew 1"-8UNC x 5 1/2" Grade 5	4	
11	91299-256	Capscrew 3/4"-10UNC x 9" Grade 8	2	
12	282310B	Hub and Spindle Assembly (Black)	2	Includes Items 13 through 26
13	282312B	Hub Assembly (Black)	2	
14	9006996	Bearing Cup	4	
15	9007001	Stud Bolt M22 x 1.5 x 4 Class 10.9	24	
16	282311	Spindle	2	
17	94981	Locknut 1/2"-13UNC	2	
18	9007854	Capscrew 1/2"-13UNC x 5 3/4" Grade 5	2	
19	9007010	Seal	2	
20	9007007	Bearing Cone	4	
21	282316	Spindle Nut	2	
22	282315	Hub Cap Gasket	2	
23	282314B	Hub Cap =Black=	2	
24	9390-028	Capscrew 5/16"-18UNC x 3/4" Grade 5	12	
25	91160	Grease Zerk	2	
26	97319	Flange Nut M22 x 1.5 Grade 10	24	
27	9008441	Locknut 1"-14UNS Gr. 8	8	
28	283895B	Spacer Bushing =Black=	2	
29	9008339	Capscrew, 1"-14UNS x 2 1/2" Gr. 8	8	

**Track Axle — For V1300 Only**

**Please visit [www.unverferth.com/parts/](http://www.unverferth.com/parts/) for the most current parts listing.**

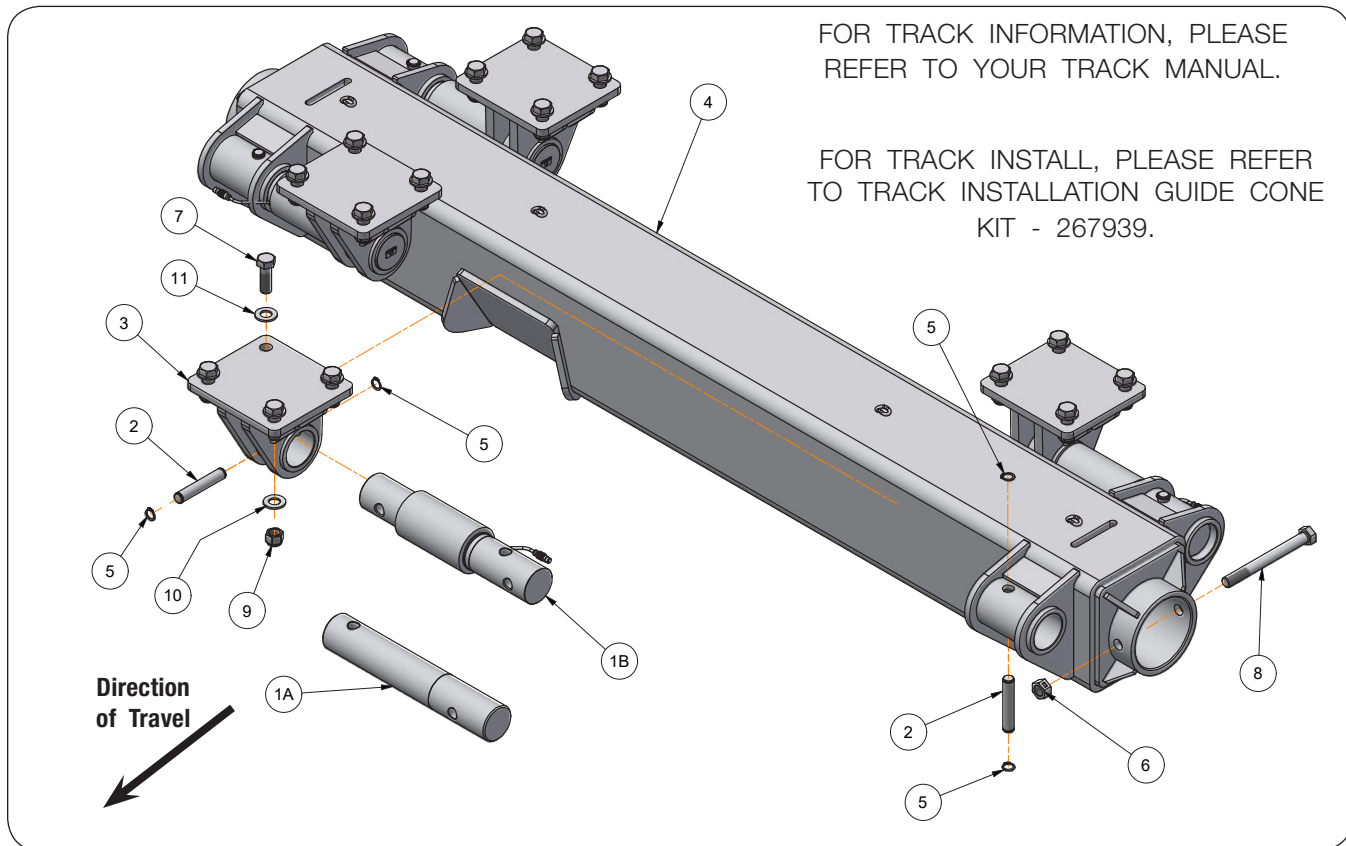
FOR TRACK INFORMATION, PLEASE REFER TO YOUR TRACK MANUAL.



ITEM	PART NUMBER	DESCRIPTION	QTY	NOTES
	288193B	Track Axle Assembly w/out Scales =Black=	1	Includes Items 1A, 2 through 12
	288192B	Track Axle Assembly w/Scales =Black=		Includes Items 1B, 2 through 12
1A	268289	Hitch Bar For Units w/out Scales	4	
1B	9004903	Hitch Bar For Units w/Scales		
2	250843	Hitch Pin 1" Dia. x 4 9/16"	8	
3	283854B	Axle Mount Casting =Black=	4	
4	288224B	Track Axle Weldment =Black=	1	
5	91192	Retaining Ring 1" Grade 5	16	
6	92199	Locknut/Center 1"-8UNC	8	
7	9008339	Capscrew 1"-14UNS x 2 1/2 Grade 8	3	
8	9390-193	Capscrew 1"-8UNC x 5" Grade 5	4	
9	9390-462	Capscrew 1"-8UNC x 8 1/2" Grade 5	2	
10	9008338	Hex Nut 1"-14UNS Grade 8	8	
11	9404-041	Lock Washer 1"	8	
12	9405-118	Flat Washer 1" USS	8	

**Track Axle — For V1500 Only**

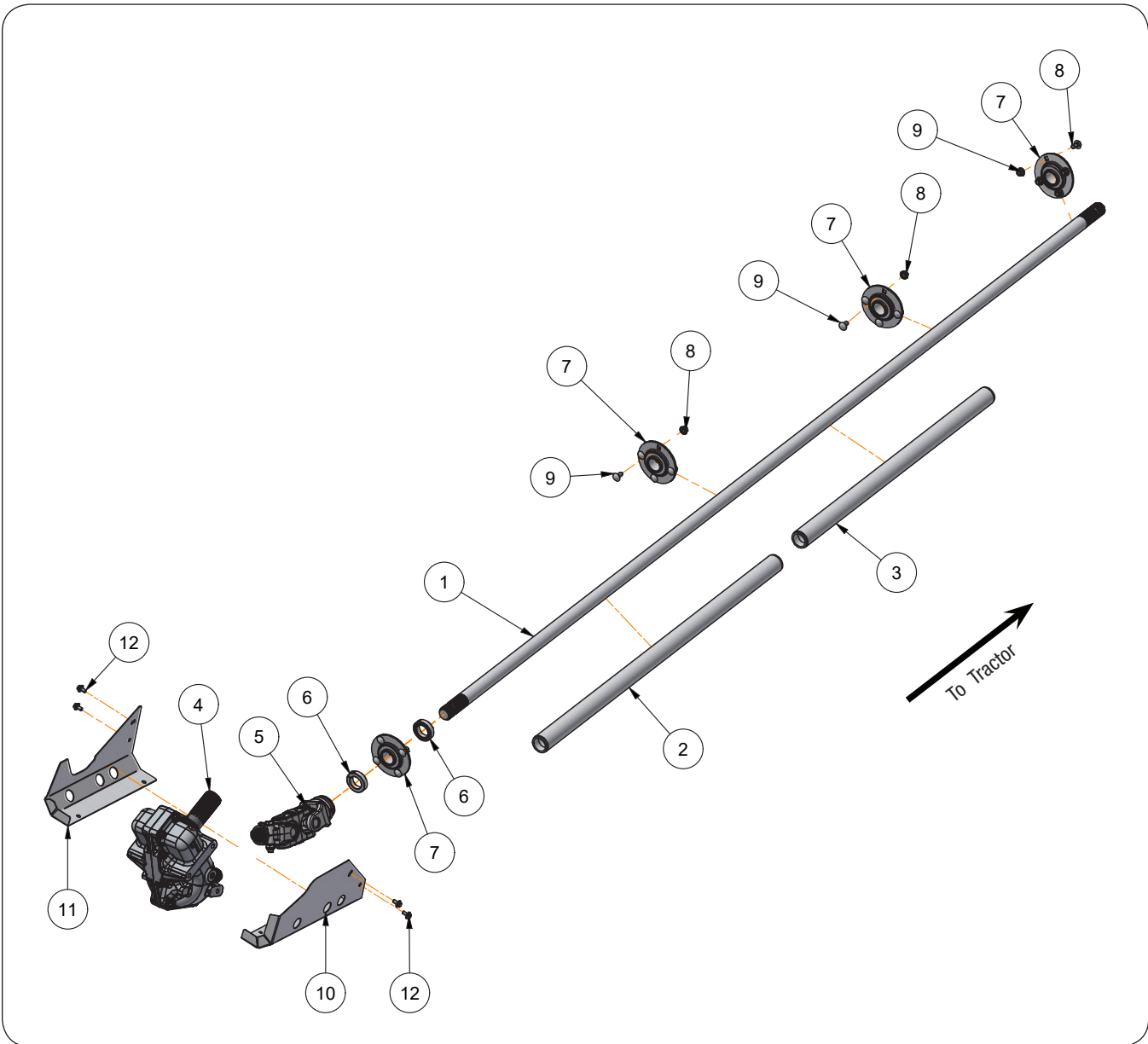
**Please visit [www.unverferth.com/parts/](http://www.unverferth.com/parts/) for the most current parts listing.**



ITEM	PART NUMBER	DESCRIPTION	QTY	NOTES
	288197B	Track Axle Assembly w/out Scales =Black=	1	Includes Items 1A, 2 through 11
	288196B	Track Axle Assembly w/Scales =Black=		
1A	282745	Hitch Bar For Units w/out Scales	4	
1B	9005811	Hitch Bar For Units w/Scales		
2	282876	Hitch Pin 1" Dia. x 5 1/2"	8	
3	288437B	Axle Mount Casting =Black=	4	
4	288225B	Track Axle Weldment =Black=	1	
5	91192	Retaining Ring 1" Grade 5	16	
6	92199	Locknut/Center 1"-8UNC	2	
7	9390-187	Capscrew 1"-8UNC x 3" Grade 5	16	
8	9390-464	Capscrew 1"-8UNC x 8 1/2" Grade 5	2	
9	9394-020	Hex Nut 1"-8UNC	16	
10	9404-041	Lock Washer 1"	16	
11	9405-118	Flat Washer 1" USS	16	

Driveline Components

Please visit [www.unverferth.com/parts/](http://www.unverferth.com/parts/) for the most current parts listing.



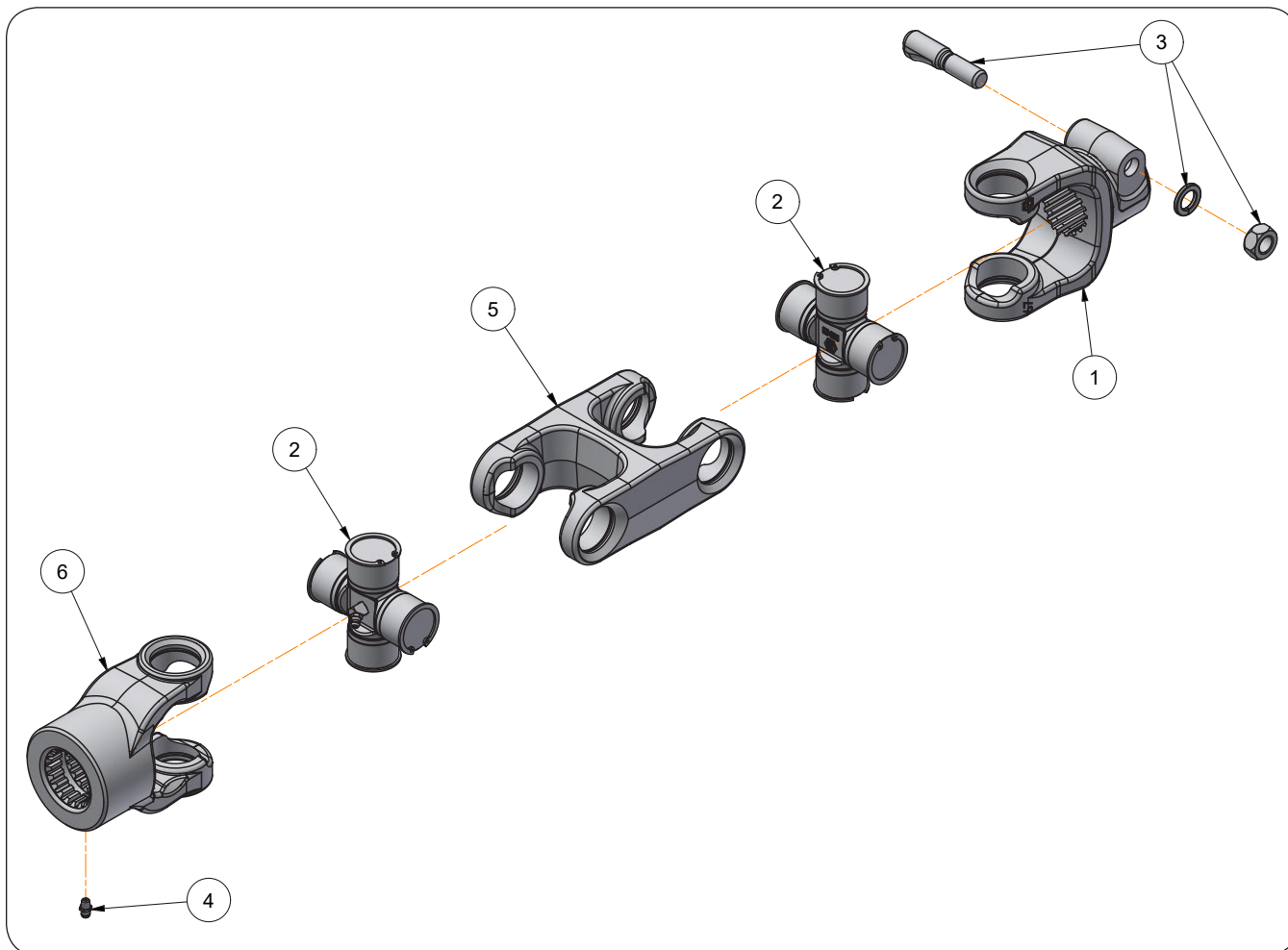
**Driveline Components**

**Please visit [www.unverferth.com/parts/](http://www.unverferth.com/parts/) for the most current parts listing.**

ITEM	PART NUMBER	DESCRIPTION	QTY.	NOTES
1	289819	Drive Shaft 1 3/4" Dia. x 144 5/8"	1	
2	293380	Tube Cover 52" Long	1	
3	288762	Tube Cover 41 1/2" Long	1	
4	9008711	45 Degree Gearbox	1	
5	9010019	Complete Double U-Joint Assembly	1	For SN B45970100 & Higher See Driveline U-Joint Assembly Section
	9007886		1	For SN B45970099 & Lower See Driveline U-Joint Assembly Section
6	9008674	Lock Collar 1 3/4" Dia.	2	
7	9005061	Flangette Bearing 1 3/4"	4	
8	91267	Flange Nut 1/2"-13UNC	16	
9	9388-102	Carriage Bolt 1/2"-13UNC x 1" Grade 5	16	
10	289833B	Outside Panel Cover U-Joint =Black=	1	
11	289834B	Inside Panel Cover U-Joint =Black=	1	
12	95585	Screw/Large Flange 3/8"-16UNC x 3/4"	16	

**Driveline U-Joint Assembly  
For SN B45970100 and Higher**

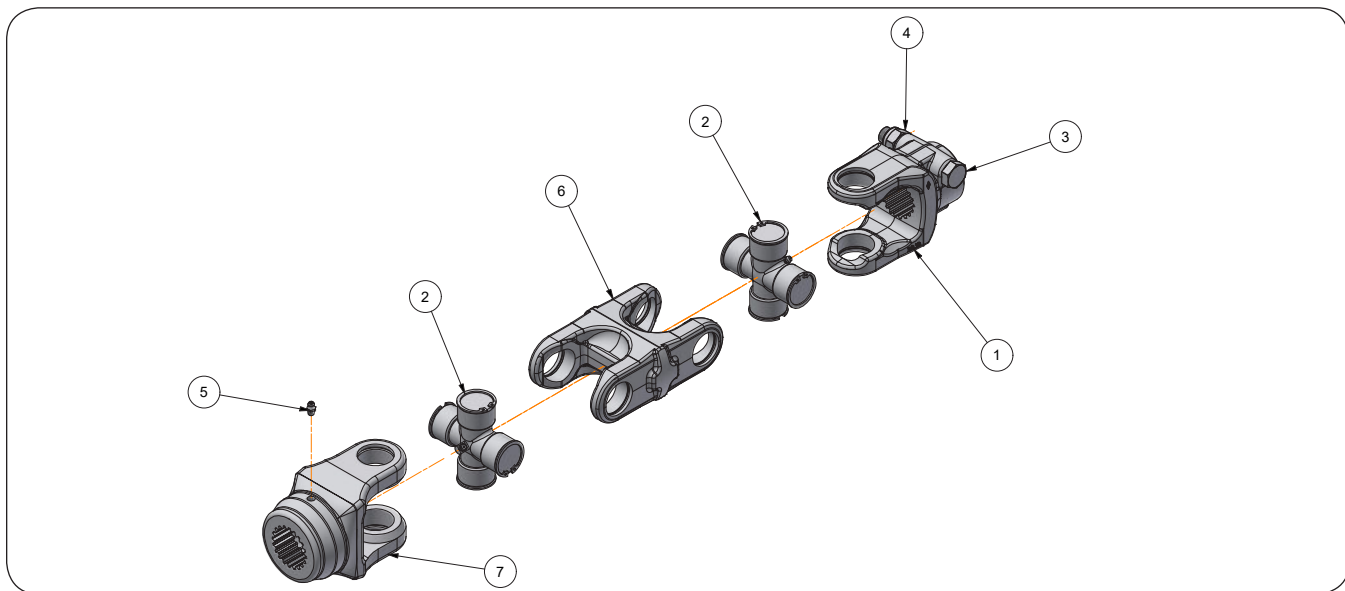
**Please visit [www.unverferth.com/parts/](http://www.unverferth.com/parts/) for the most current parts listing.**



ITEM	PART NO.	DESCRIPTION	QTY.	NOTES
	9010019	Complete Double U-Joint Assembly	1	
1	9010012	Yoke 1 3/4" -20 Spline with Conic Bolt	1	
2	9010020	Cross Bearing Kit	2	
3	9008789	Conic Bolt Set	1	Includes Conic Bolt and Hardware Torque Conic Bolt To 74 Ft.-Lbs.
4	91160	Grease Zerk	1	
5	9010016	Yoke/Double Center	1	
6	9010015	Yoke 1 3/4" -20 Spline	1	

**Driveline U-Joint Assembly  
For SN B45970099 and Lower**

**Please visit [www.unverferth.com/parts/](http://www.unverferth.com/parts/) for the most current parts listing.**

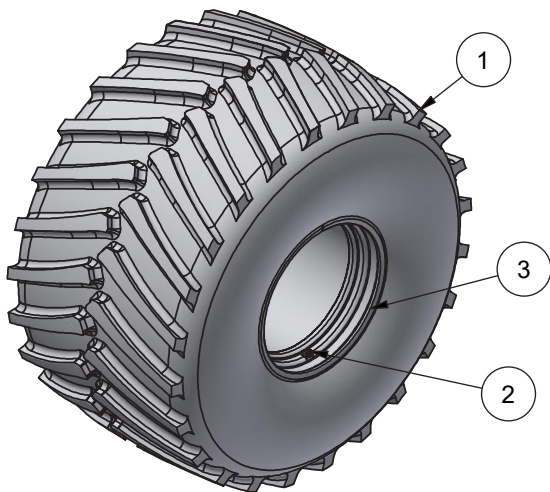


ITEM	PART NO.	DESCRIPTION	QTY.	NOTES
	9007886	Complete U-Joint Assembly	1	
1	9007829	Yoke 1 3/4-20 Spline with Interference Clamp Connection	1	
2	92529	Cross Bearing Kit	2	
3	94916-127	Capscrew M16 x 90 Class 8.8	1	
4	9002785	Lock Nut M16	1	
5	91160	Grease Zerk	1	
6	92533	Yoke/Center	1	
7	9005318	Yoke 1 3/4-20 Spline	1	



**Single Wheels & Tires**

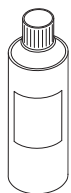
**Please visit [www.unverferth.com/parts/](http://www.unverferth.com/parts/) for the most current parts listing.**



**TIRES**  
 For questions regarding new tire warranty, please contact your local original equipment tire dealer. Used tires carry no warranty.

ITEM	PART NUMBER	DESCRIPTION	QTY.	NOTES
1	110598SM/9500943	Wheel & Tire Assembly	2	44 x 32 / TLIF1250/50R32F R-1W (201D) (V1300)
	111499SM			44 x 32 / TLIF1250/50R32AL R-1W (201B) (V1500)
2	93300	Valve Stem	2	
3	110598SM	Wheel Only	2	44 x 32 (V1300)
	110566SM			44 x 32 (V1500)

**Touch-Up Paint**



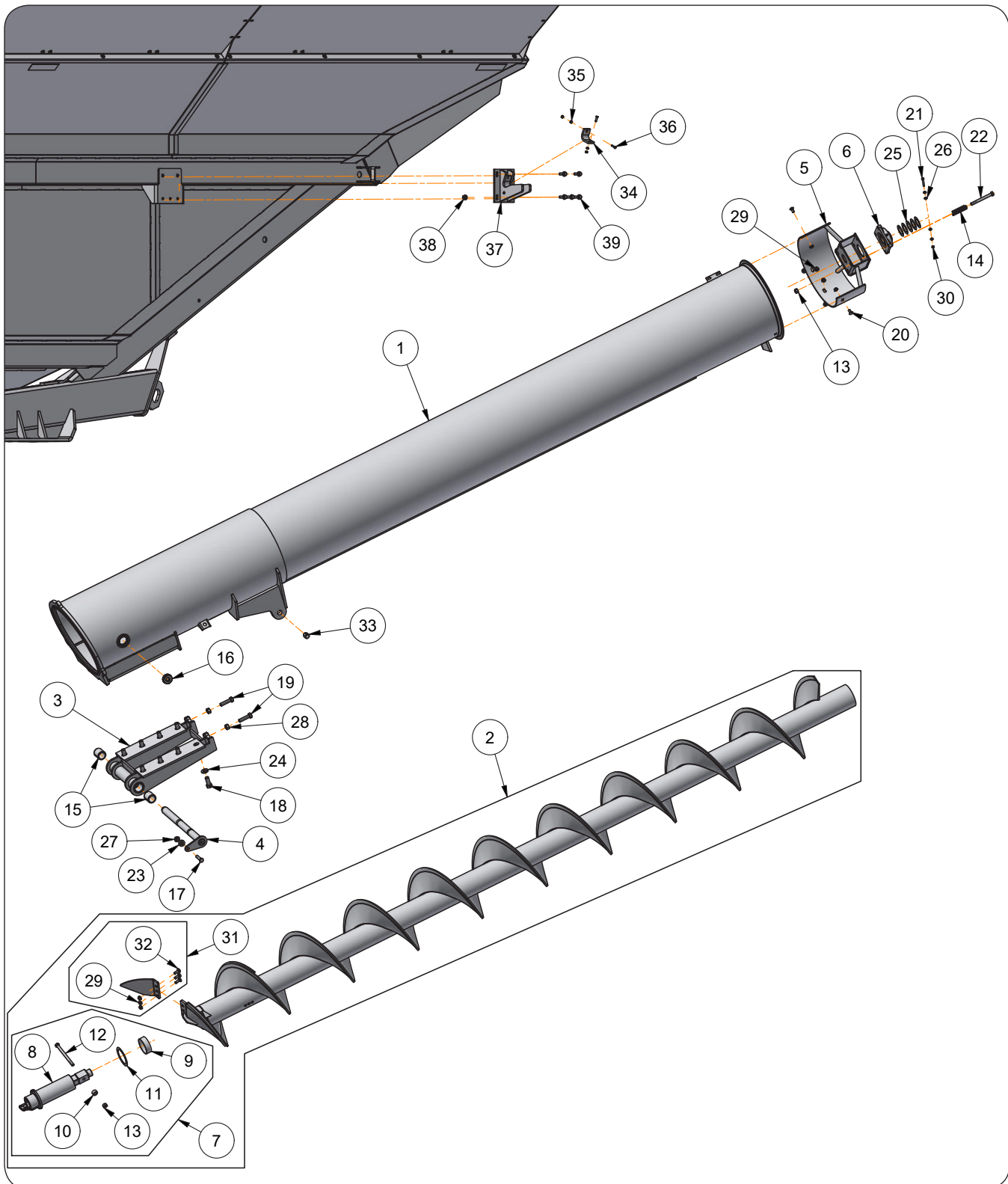
PAINT	SPRAY
Black	97013
Green	97015
Red	97301
Sliver Mist	97012
Black Metallic	9504382

**Notes**

**Please visit [www.unverferth.com/parts/](http://www.unverferth.com/parts/) for the most current parts listing.**

## Upper Auger Components

Please visit [www.unverferth.com/parts/](http://www.unverferth.com/parts/) for the most current parts listing.



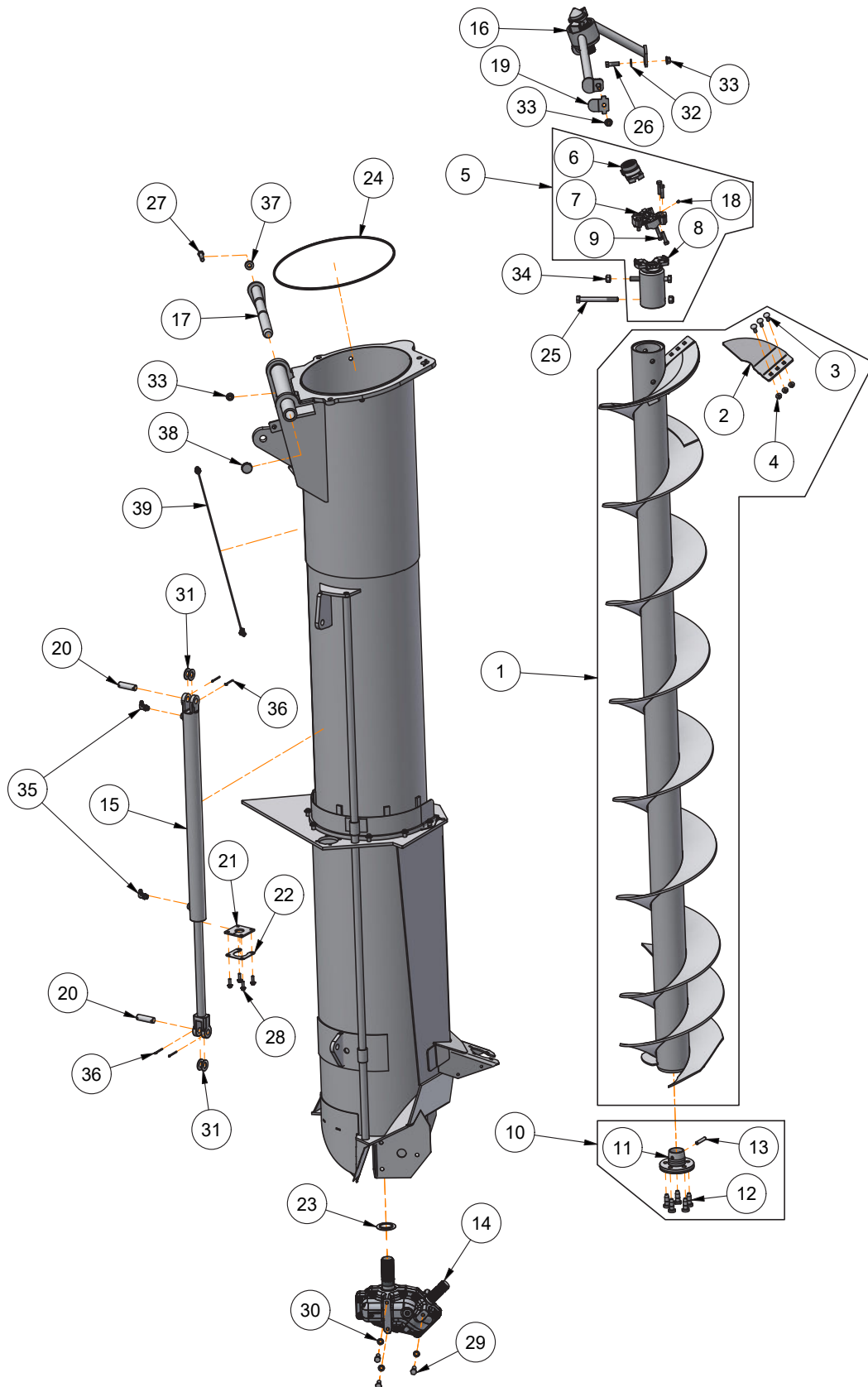
**Upper Auger Components**

**Please visit [www.unverferth.com/parts/](http://www.unverferth.com/parts/) for the most current parts listing.**

ITEM	PART NUMBER	DESCRIPTION	QTY	NOTES
1	288899G	Upper Auger Housing Replacement Kit =Green=	1	
	288899R	Upper Auger Housing Replacement Kit =Red=		
	288899BM	Upper Auger Housing Replacement Kit =Black Metallic=		
2	291667B	Upper Auger Replacement Kit =Black=	1	Includes Upper Auger and Items 5 & 7
3	286984G	Upper Auger Pivot Weldment =Green=	1	
	286984R	Upper Auger Pivot Weldment =Red=		
	286984BM	Upper Auger Pivot Weldment =Black Metallic=		
4	268946	Pivot Shaft Weldment	1	
5	296451B	Hanger Bearing Weldment =Black=	1	
6	9002492	Flanged Bearing 2" Dia.	1	
7	296488B	Soft Start Kit	1	Includes Items 8-13
8	278004	Soft Start Assembly	1	
9	9004877	Bushing 4 1/4" OD x 4" ID x 1.375"	1	
10	405402B	Bushing 1 1/4" OD x 1 1/16" ID x 11/16" =Black=	1	
11	9004878	Thrust Washer 5 1/4" OD x 4 1/16" ID x .078"	1	
12	9390-442	Capscrew 5/8"-11UNC x 9" Grade 5	1	
13	9801	Locknut/Top 5/8"-11UNC	5	
14	9001812	Compression Spring	4	
15	9004980	Split Tension Bushing 2 1/4" OD x 1 3/4" ID x 2.5"	2	
16	9008430	Hex Socket Plug	1	
17	9390-126	Capscrew 5/8"-11UNC x 2 1/2" Grade 5	1	
18	9390-165	Capscrew 7/8"-9UNC x 2 1/4" Grade 5	8	
19	94733	Capscrew 3/4"-10UNC x 3" Grade 5 (Full Threaded)	2	
20	9388-102	Carriage Bolt 1/2"-13UNC x 1" Grade 5	4	
21	9390-037	Capscrew 5/16"-18UNC x 2 3/4" Grade 5	1	
22	9390-136	Capscrew 5/8"-11UNC x 6" Gr.5	6	
23	268896	Spacer Bushing 1 1/2" OD x 3/4" ID x 1/2"	1	
24	97041	Flat Washer 7/8"	8	
25	93974	Flat Washer 2"	AR	
26	9405-068	Flat Washer 5/16" SAE	4	
27	9003398	Locknut/Top 5/8"-11UNC	4	
28	9394-016	Hex Nut 3/4"-10UNC	2	
29	9003397	Locking Flange Nut 1/2"-13UNC	6	
30	901527	Locknut/Center 5/16"-18UNC	1	
31	293466B	Upper Auger Extension Replacement Kit =Black=	1	Includes Upper Auger Extension & Items 29 & 32
32	9388-104	Carriage Bolt 1/2"-13UNC x 1 1/2" G5	3	
33	91268	Split Tension Bushing	1	
34	9004263	Stop Pad (2" x 4 3/8")	1	
35	9394-004	Hex Nut 5/16"-18UNC G5	4	
36	903171-662	Flat Head 5/16"-18UNC x 1 1/4" Phillips Machine Screw G5	2	
37	268942G	Rest Weldment =Green=	1	
	268942R	Rest Weldment =Red=		
	268942BM	Rest Weldment =Black Metallic=		
38	91267	Flange Nut, 1/2"-13UNC G5	3	
39	9005705	Flange Screw, 1/2"-13UNC x 1 1/2" G5	5	

## Lower Auger Components

Please visit [www.unverferth.com/parts/](http://www.unverferth.com/parts/) for the most current parts listing.



**Lower Auger Components**

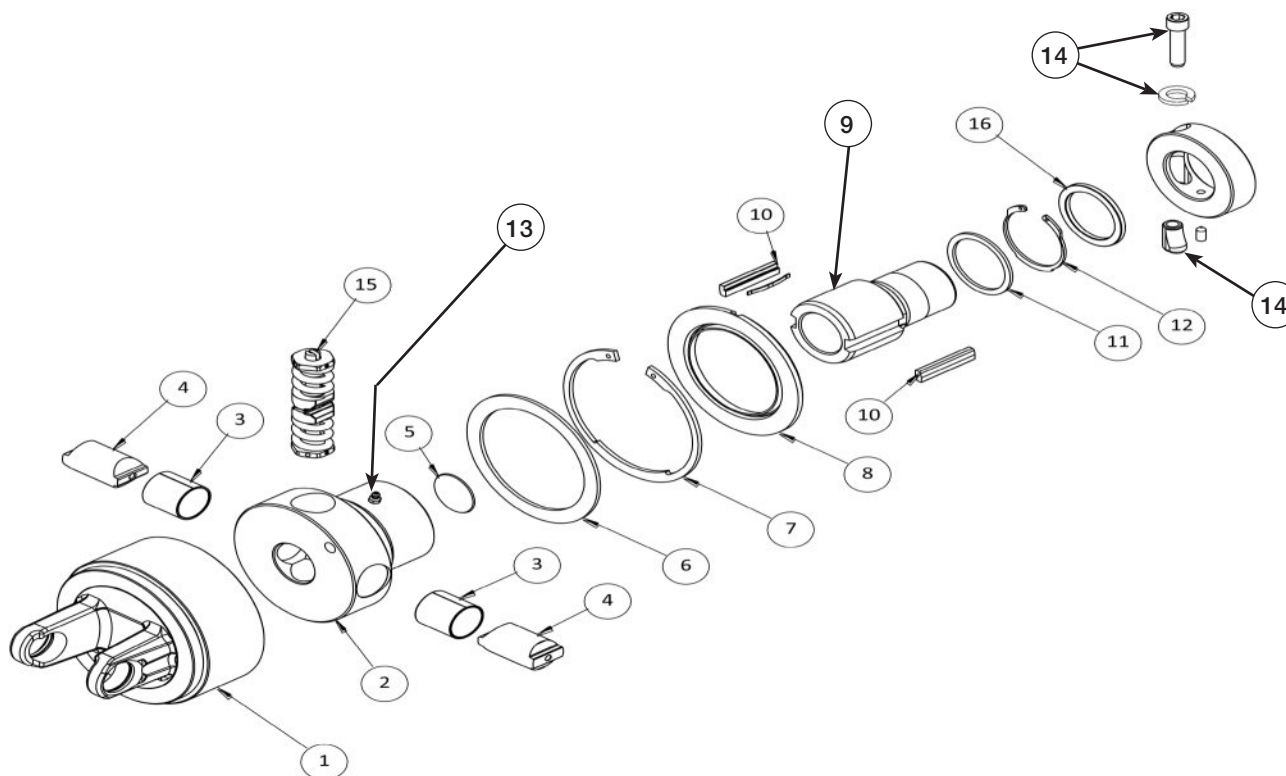
**Please visit [www.unverferth.com/parts/](http://www.unverferth.com/parts/) for the most current parts listing.**

ITEM	PART NUMBER	DESCRIPTION	QTY	NOTES
1	291825B	Lower Auger Replacement Kit =Black=	1	Includes Lower Auger and Items 2-4
2	296457B	Lower Auger Extension Plate =Black=	1	Replacement kit #296456B Includes Item 2-4
3	9388-104	Carriage Bolt 1/2"-13UNC x 1 1/2" Grade 5	3	
4	9003397	Lock Nut 1/2"-13UNC	3	
5	283452	U-Joint Assembly	1	Includes Items 6-9 and 18
6	280065	Yoke-Spline, 31 Tooth	1	
7	9008443	Wing Bearing Assembly	1	
8	288453	Adapter Tube Yoke Assembly	1	
9	9008432	Capscrew 1/2"-20 UNF x 2" Grade 8	8	
10	287802	Auger Drive Plate Assembly, 5-Pin	1	Includes Items 11-13
11	287801	Auger Drive Plate	1	
12	9007000	Headed Drive Pin	5	
13	902614-238	Spiral Pin 1/2" Dia x 2 3/4"	1	
14	9008711	45 Degree Gearbox	1	
15	9005363	Hydraulic Cylinder 2 1/2" x 36"	1	
16	293454B	Hanger Bearing Replacment Kit =Black=	1	
17	268946	Pivot Shaft Weldment	1	
18	91160	Grease Zerk	1	
19	288678B	Shim 12GA x 2" x 3 5/16" =Black=	1	
	288679B	Shim 12GA x 3 3/8" x 3 3/4" =Black=	2	
20	804572	Hydraulic Cylinder Pin 1" Dia. x 3 1/2"	2	
21	268217	Rubber Gasket, 4" x 4"	1	
22	268218	Cover Plate	1	
23	9007377B	Dust Cover =Black=	1	
24	296290	Lower Auger Gasket Seal Kit	1	Includes Instruction Sheet
25	9390-159	Capscrew 3/4"-10UNC x 7" Grade 5	2	
26	9390-124	Capscrew 5/8"-11UNC x 2" Grade 5	3	
27	9390-127	Capscrew 5/8"-11UNC x 2 3/4" Grade 5	1	
28	9003259	Flange Screw 3/8"16UNC x 1 1/4" Grade 5	4	
29	9390-123	Capscrew 5/8"-11UNC x 1 3/4" Grade 5	6	
30	9404-029	Lock Washer 5/8"	6	
31	9405-116	Flat Washer 1" SAE	4	
32	9405-098	Flat Washer 5/8" SAE	3	
33	9003398	Flange Lock Nut 5/8"-11UNC	4	
34	9802	Lock Nut 3/4"-10UNC	2	
35	9874	90° Elbow 9/16"-18 JIC Male x 3/4"-16 O-Ring Male	2	
36	9391-046	Cotter Pin 3/16" Dia x 2"	4	
37	268896	Spacer Bushing	1	
38	9009934	Plug 1 7/8" Dia	1	
39	9007472	Proximity Sensor W/Connector	1	

**PTO Cut Out Clutch Components (Benzi America)**

**Please visit [www.unverferth.com/parts/](http://www.unverferth.com/parts/) for the most current parts listing.**

For Benzi PTO Components, U-Joint Color is Gray.



**NOTE:** Clutch Assembly (9009780) Must be used with the complete PTO Assembly (9009527).

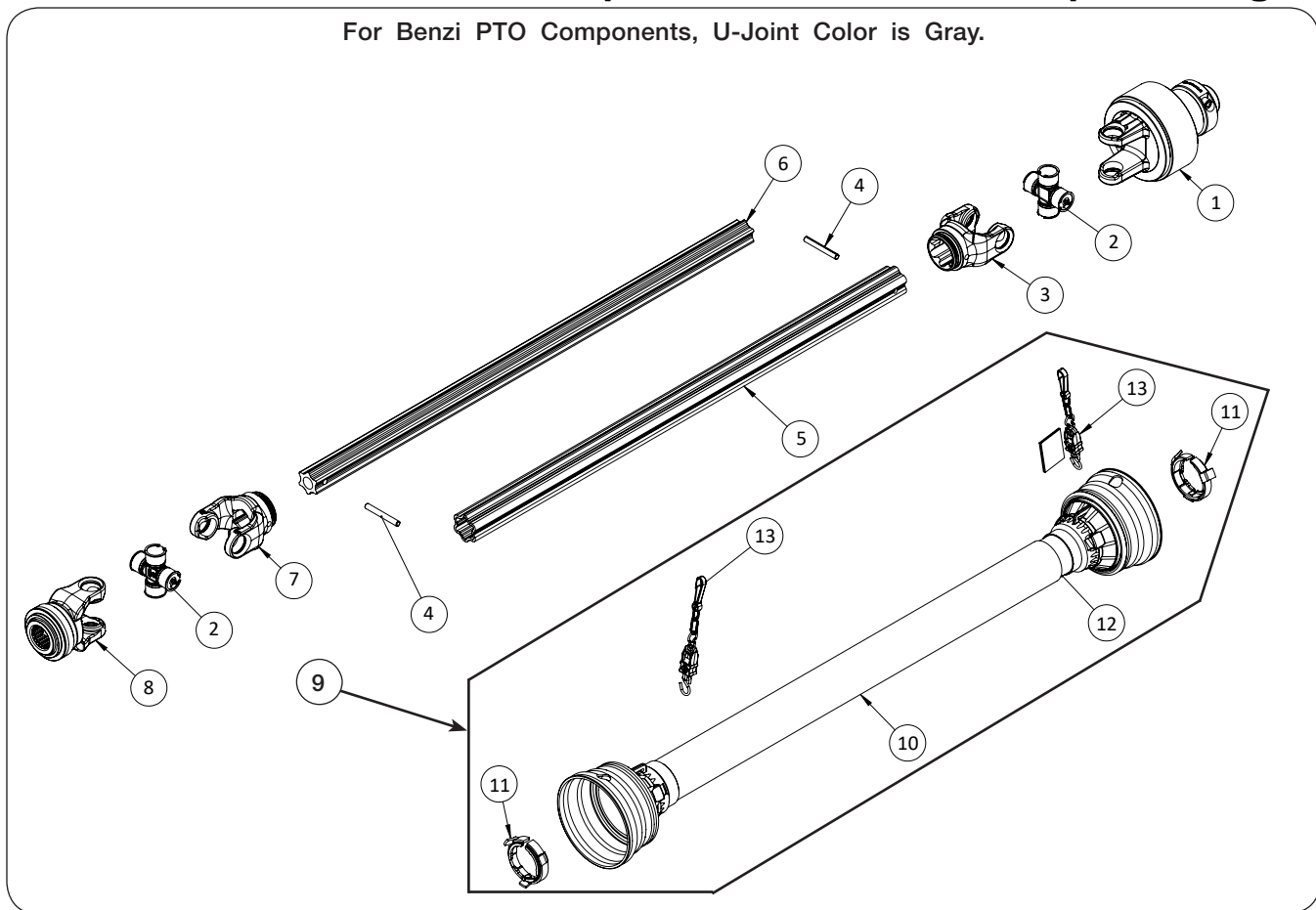
ITEM	PART NO.	DESCRIPTION	QTY	NOTES
	9009780	Cut Out Clutch (2500 N*m Setting)		Includes Items 1-16
1	9008775	Clutch Housing	1	
2	9008776	Clutch Hub 1 3/4-20 Spline	1	
3	9008778	Bushing	2	
4	9008779	Pusher Rod	2	
5	9008780	Closer Ring	1	
6	9008781	Washer	1	
7	9008872	Snap Ring	1	
8	9008783	Grease Seal	1	
9	9008784	Over Running Clutch Hub	1	Includes Collar With Set Screw
10	9008785	Over Running Clutch Spring Pack	1	
11	9008786	Washer	1	
12	9008787	Snap Ring	1	
13	9008788	Grease Zerk (M8)	1	
14	9008789	Conic Bolt Set	1	Includes Socket Head Bolt, Lock Washer, and Threaded Insert
15	9009788	Automatic Cam Clutch Spring Assembly	1	
16	9009789	Clutch Hub Ring	1	



**PTO Components (Benzi America)**

**Please visit [www.unverferth.com/parts/](http://www.unverferth.com/parts/) for the most current parts listing.**

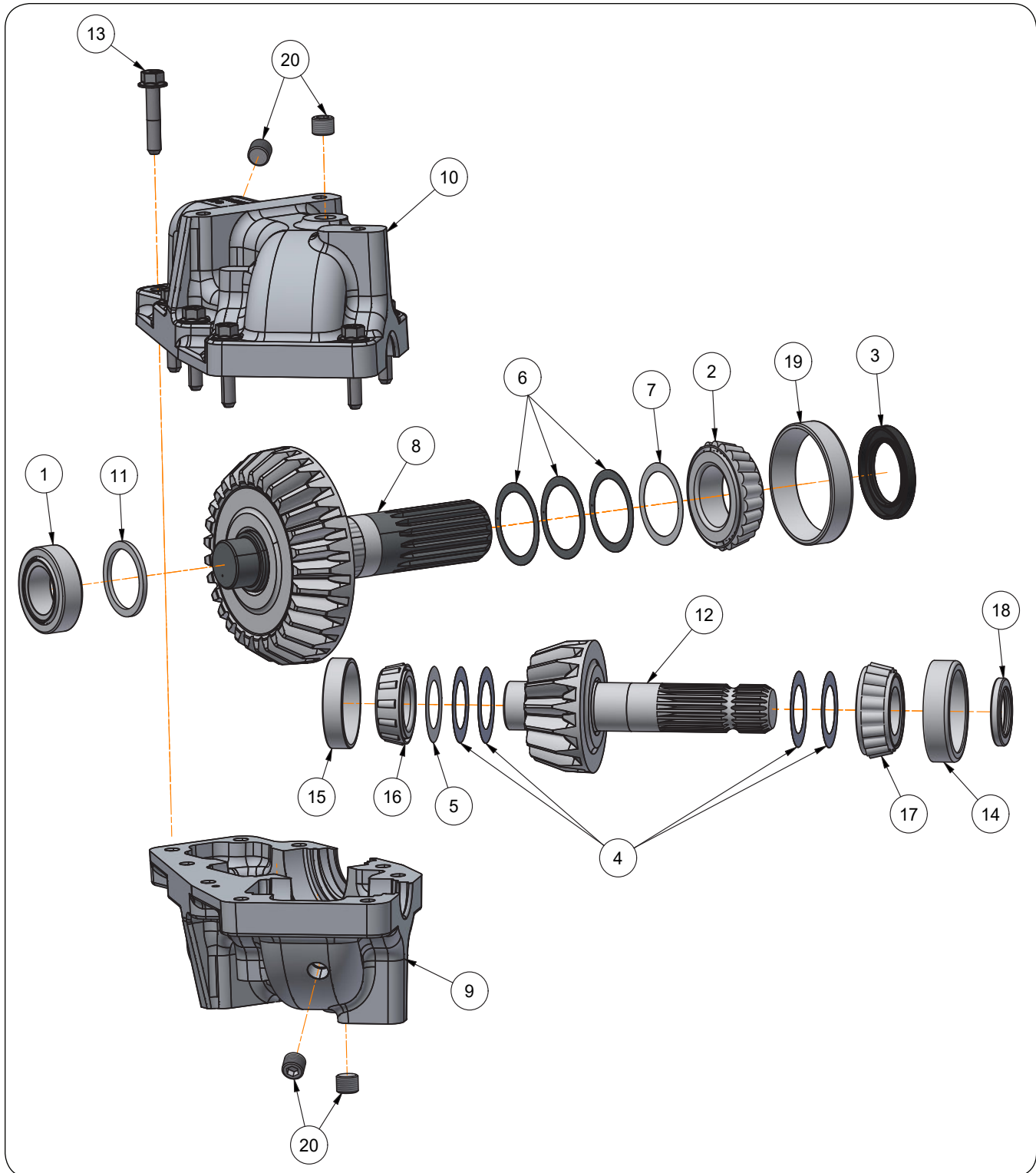
For Benzi PTO Components, U-Joint Color is Gray.



ITEM	PART NO.	DESCRIPTION	QTY	NOTES
	9009527	PTO Assembly Complete	1	Includes items 1 and 2
	9009792	PTO Rear Half Assembly	1	Includes items 2, 4, 6, and 9
	9009791	PTO Front Half Assembly	1	Includes items 1-5 & 9
1	9009780	Clutch Assembly	1	1 3/4"-20 Spline 1000RPM
2	9008792	Cross Universal Kit	2	
3	9008793	Outer Yoke	1	
4	9008794	Tension Pin	2	
5	9008795	Outer Profile Tube w/ Cap	1	
6	9009778	Inner Profile Tube W/ Cap	1	
7	9008797	Inner Yoke	1	
8	9008798	Yoke Assembly	1	
9	9009781	Safety Guard Assembly	1	
10	N/A	Outer Guard Half	1	
11	9008801	Retainer Clip PKG-Cone, Gaurding	1	Package of 2
12	N/A	Inner Guard Half	1	
13	9008804	Chain	2	

### 45 Degree Gearbox

Please visit [www.unverferth.com/parts/](http://www.unverferth.com/parts/) for the most current parts listing.



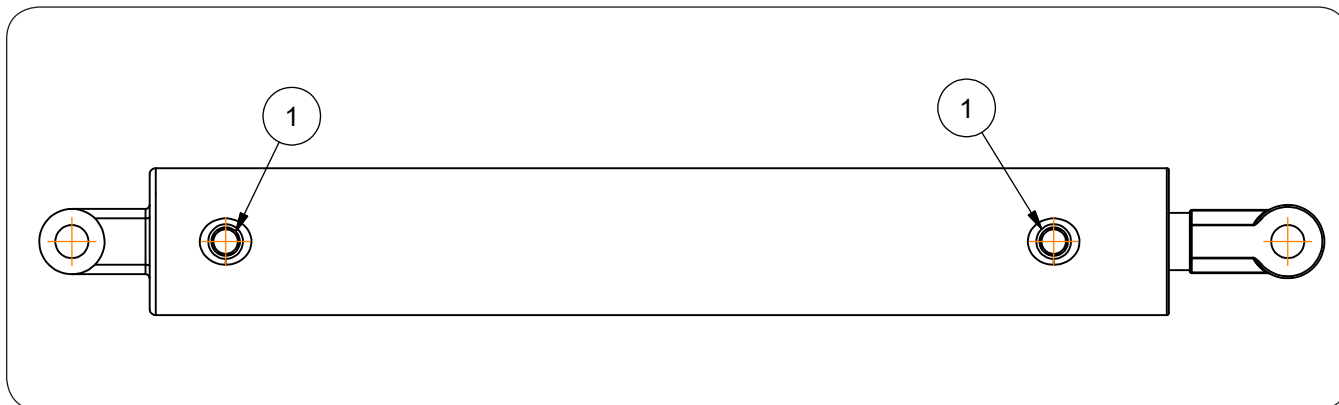
**45 Degree Gearbox**

**Please visit [www.unverferth.com/parts/](http://www.unverferth.com/parts/) for the most current parts listing.**

ITEM	PART NO.	DESCRIPTION	QTY.	NOTES
	9008711	Gearbox 45° Q135 Series, Complete	1	Includes Items 1 through 20
1	9007488	Bearing Cup/Cone, 3.15" OD x 1.772" ID	1	
2	9007507	Bearing Cone, 2 1/4" ID x 1 1/4"	1	
3	9007508	Seal	1	
4	9007509	Steel Shim, 2.75" x 1.75" x .005"	4	
5	9007510	Steel Shim, 2.75" x 1.75" x .003"	1	
6	9007511	Steel Shim, 3.00" x 2.36" x .005"	3	
7	9007512	Steel Shim, 3.00" x 2.36" x .003"	1	
8	9007516	Gear Shaft Assembly, 29 Tooth, 2 1/4"-17 Spline	1	
9	9008509	Gearbox Housing Q135 w/Tapped Holes	1	
10	9008510	Gearbox Housing Q135 w/Thru Holes	1	
11	9008511	Spacer	1	
12	9008790	Gear Shaft Assembly, 16 Tooth, 1 3/4"-20 Spline	1	
13	903161-060	Flange Screw, 1/2"-13UNC x 2 1/2" G5	9	
14	91151	Bearing Cup, #3720	1	Large
15	91812	Bearing Cup, 3.265" OD x 0.75"	1	
16	91822	Bearing Cone, 1.75" ID	1	
17	92697	Bearing Cone, 1.750" ID x 1 1/4"	1	Large
18	92702	Seal	1	Large
19	93819	Bearing Cup, 4 7/16" OD x 15/16"	1	
20	95283	Pipe Plug, 1/2" NPT	4	

**Cylinders — 4" x 24" (Auger Fold)**

Please visit [www.unverferth.com/parts/](http://www.unverferth.com/parts/) for the most current parts listing.

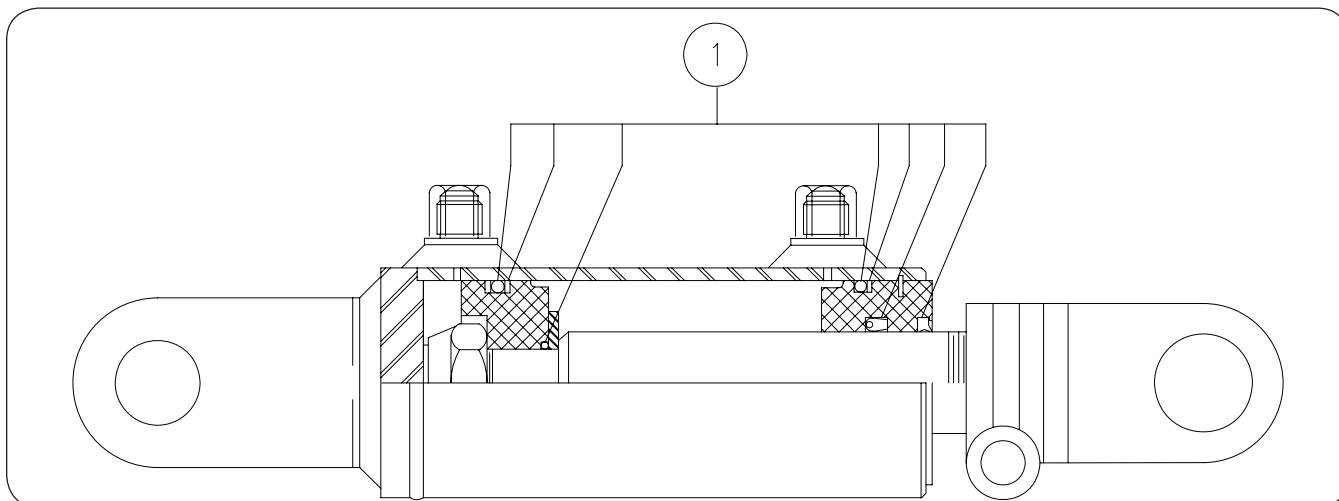


ITEM	PART NUMBER	DESCRIPTION	QTY.	NOTES
	9007786	Welded Cylinder, Complete	1	
1	9008025	Seal Kit	1	

**Cylinders — 2 1/2" x 36" (Flow Door)**

ITEM	PART NUMBER	DESCRIPTION	QTY.	NOTES
	9005363	Welded Cylinder, Complete	1	
1	9005409	Seal Kit	1	

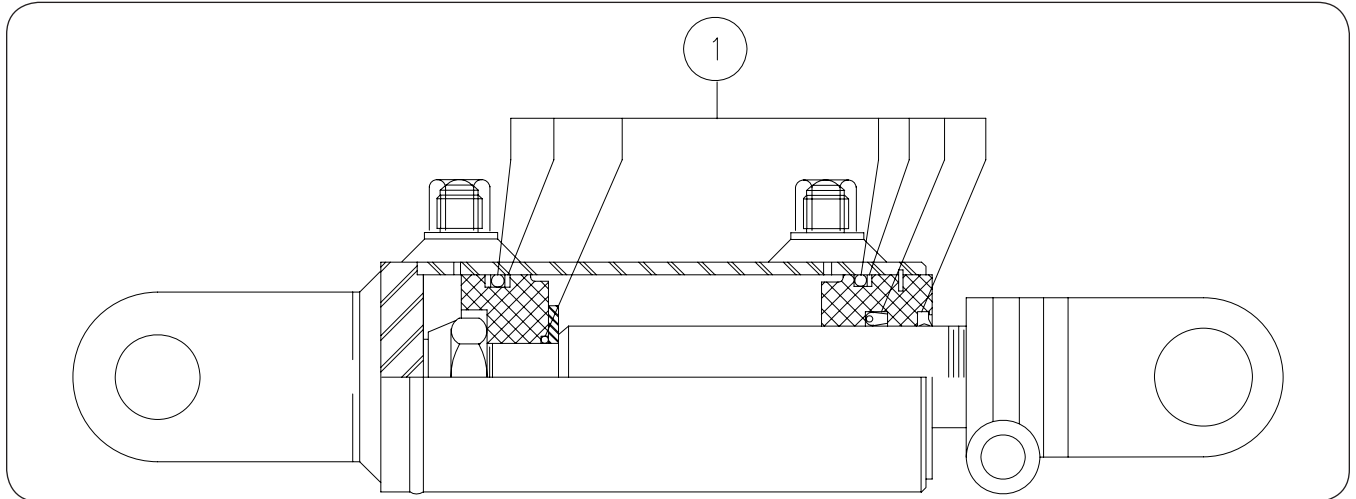
**Cylinders — 1 1/2" x 4" (Discharge Spout)**



ITEM	PART NUMBER	DESCRIPTION	QTY.	NOTES
	9003789	Welded Cylinder, Complete	1	
1	9005419	Seal Kit	1	

**Cylinders — 3 1/2" x 8" (Optional Hydraulic Jack)**

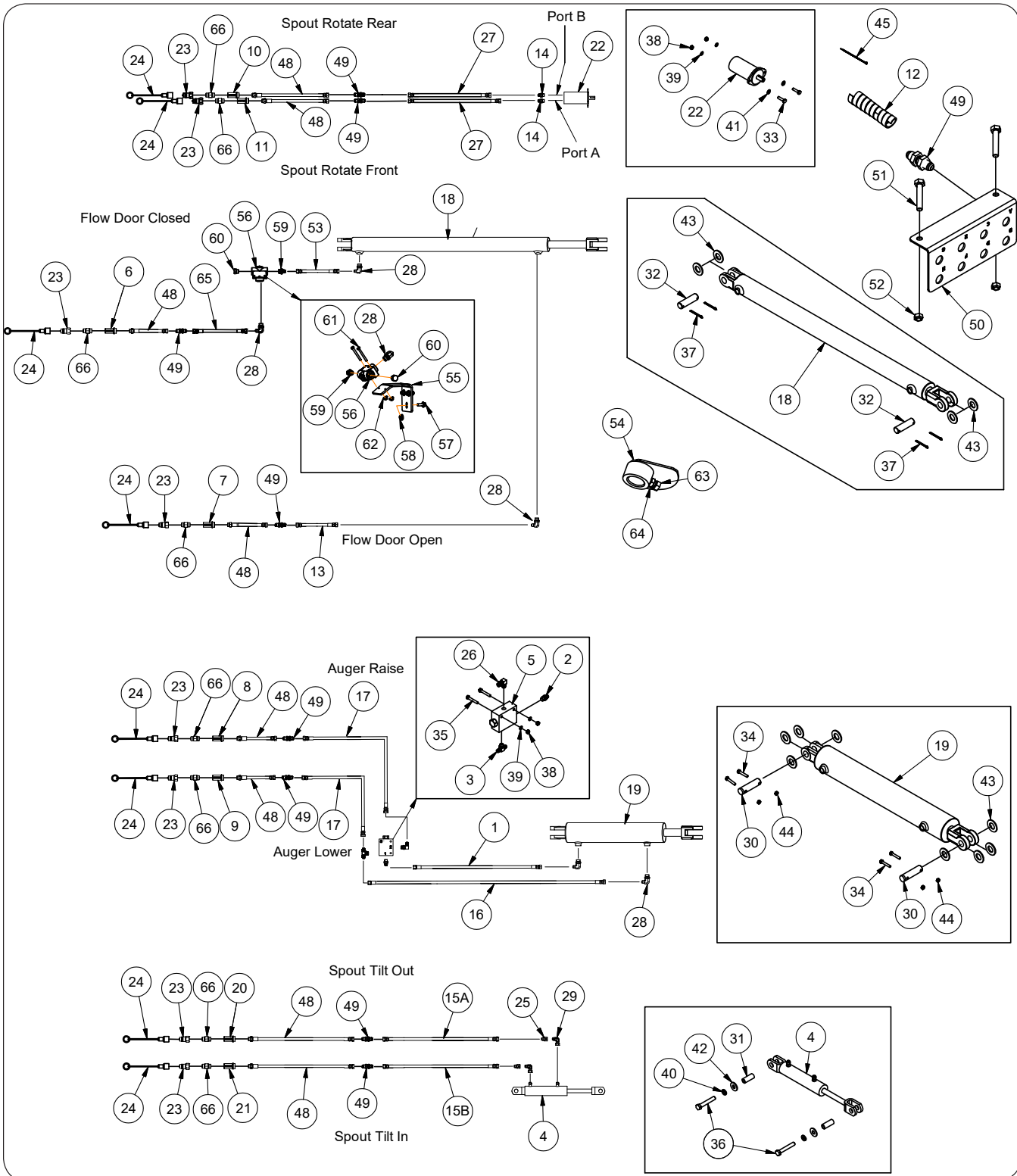
**Please visit [www.unverferth.com/parts/](http://www.unverferth.com/parts/) for the most current parts listing.**



ITEM	PART NUMBER	DESCRIPTION	QTY.	NOTES
	9009047	Welded Cylinder, Complete	1	
1	9007880	Seal Kit	1	

Hydraulics

Please visit [www.unverferth.com/parts/](http://www.unverferth.com/parts/) for the most current parts listing.



**Hydraulics**

**Please visit [www.unverferth.com/parts/](http://www.unverferth.com/parts/) for the most current parts listing.**

ITEM	PART NUMBER	DESCRIPTION	QTY	NOTES
1	97405	Hose 1/4" x 74" (9/16"-18 JIC Female x 9/16"-18 JIC Female)	1	
2	9001495	Adapter (9/16"-18 JIC Male x 9/16"-18 O-Ring Male)	1	
3	9001710	Tee (9/16"-18 JIC M x 9/16"-18 O-Ring M x 9/16"-18 JIC M)	1	
4	9003789	Hydraulic Cylinder 1 1/2" x 4"	1	
	9005419	Seal Kit	-	
5	9003990	Pilot Operated Check Valve Block	1	
6	9009755	Hose Grip, Flow Door Close (Red -)	1	
7	9009754	Hose Grip, Flow Door Open (Red +)	1	
8	9009751	Hose Grip, Auger Unfold (Green +)	1	
9	9009752	Hose Grip, Auger Fold (Green -)	1	
10	9009765	Hose Grip, Spout Rotate Rear (Tan +)	1	
11	9009766	Hose Grip, Spout Rotate Front (Tan -)	1	
12	9004075	Spiral Hose Wrap	4	
13	9003211	Hose 1/4" x 117" (9/16"-18 JIC Female x 9/16"-18 JIC Female)	1	
14	9004393	Adapter	2	
15A	9008411	Hose 1/4" x 394" (9/16"-18 JIC Female x 9/16"-18 JIC Female)	1	
15B	9004886	Hose 1/4" x 390" (9/16"-18 JIC Female x 9/16"-18 JIC Female)	1	
16	9005974	Hose 1/4" x 97" (9/16"-18 JIC Female x 9/16"-18 JIC Female)	1	
17	94727	Hose 1/4" x 18" (90° Elbow 9/16"-18 JIC Female x 9/16"-18 JIC Female)	2	
18	9005363	Flow Door Cylinder 2 1/2" x 36"	1	
	9005409	Seal Kit	-	
19	9007786	Hydraulic Cylinder, 4" x 24" - 3000 PSI	1	
	9008025	Seal Kit	-	
20	9009759	Hose Grip, Spout Tilt Out (Yellow +)	1	
21	9009760	Hose Grip, Spout Tilt In (Yellow -)	1	
22	9010071	Spout Hydraulic Motor, 1 1/4" Dia. Shaft	1	Bolt Together Item
	9007626	Spout Hydraulic Motor, 1" Dia. Shaft	1	Single Piece Item
	9008974	Seal Kit	-	Used With #9007626
23	91383	Male Coupler 3/4"-16 Female O-Ring	8	
24	91511	Dust Cap	8	
25	95193	Adapter (9/16"-18 JIC Female x 9/16"-18 JIC Male)	2	w/.030" Restrictor
26	97445	90° Elbow (9/16"-18 JIC Male x 9/16"-18 O-Ring Male)	1	
27	9003110	Hose 1/4" x 295 1/2" (9/16"-18 JIC F x 9/16"-18 JIC F)	2	For Spout Hydraulic Motor
28	9874	90° Elbow (9/16"-18 JIC Female x 3/4"-16 O-Ring Male)	5	
29	9876	90° Elbow (9/16"-18 JIC Female x 9/16"-18 JIC Male)	2	
30	291988	Pin	2	
31	285290	Sleeve/Bushing	2	
32	804572	Pin 1" Dia. x 3 1/2" (For Auger & Door Cylinders)	2	
33	9390-031	Capscrew 5/16"-18UNC x 1 1/4" Grade 5	2	
34	9390-032	Capscrew 5/16"-18UNC x 1 1/2" Grade 5	4	
35	9390-034	Capscrew 5/16"-18UNC x 2" Grade 5	2	
36	9390-108	Capscrew 1/2"-13UNC x 3 1/4" Grade 5	2	
37	9391-046	Cotter Pin 3/16" Dia. x 2"	4	
38	9394-004	Hex Nut 5/16"-18UNC	2	
39	9404-019	Lock Washer 5/16"	2	
40	9404-025	Lock Washer 1/2"	2	
41	9405-068	Flat Washer 5/16" SAE	2	
42	9405-088	Flat Washer 1/2" USS	2	
43	9405-116	Flat Washer 1" SAE	12	
44	9807	Locknut 5/16"-18UNC	4	

(Continued on next page)



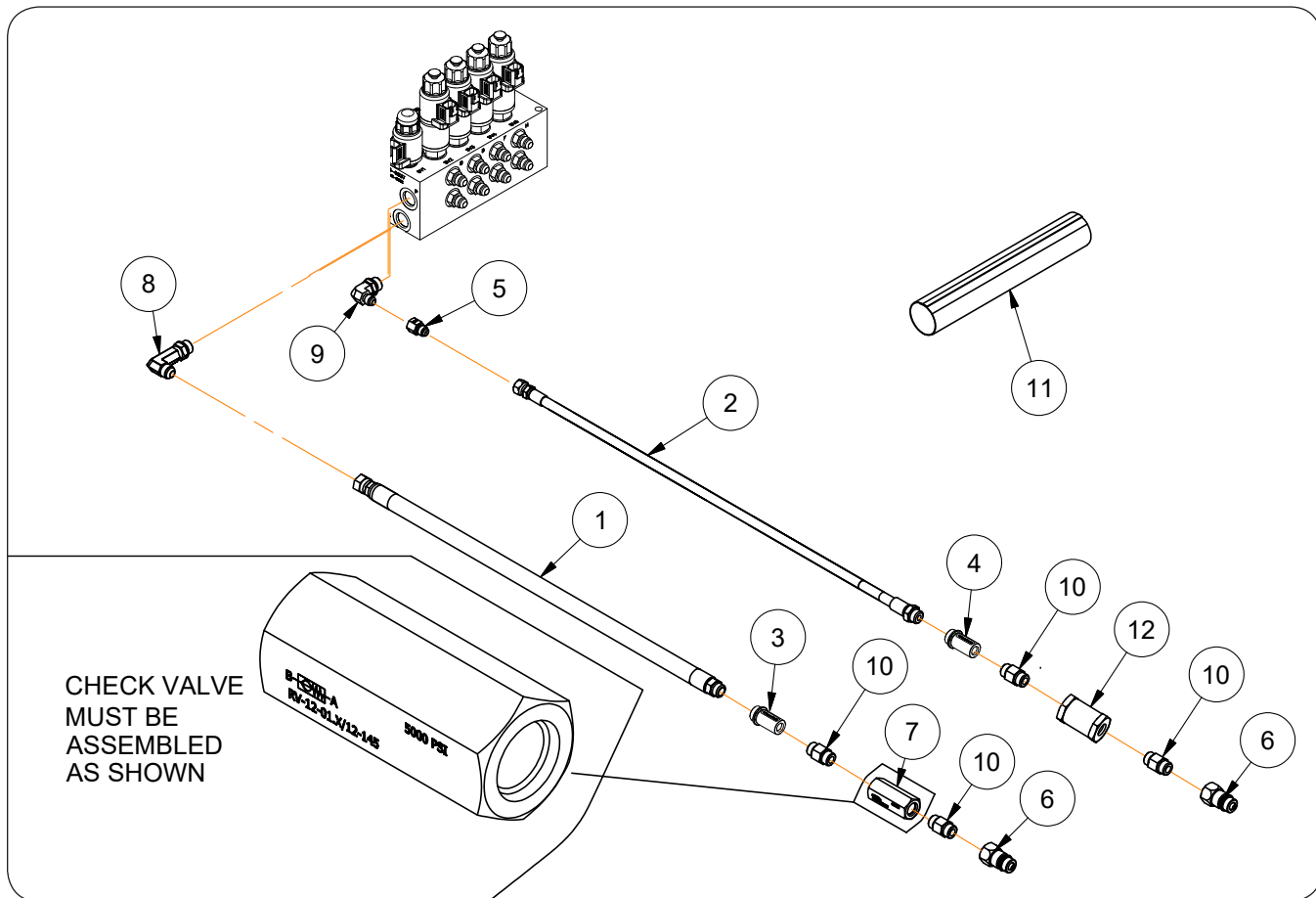
**Hydraulics** (continued)

**Please visit [www.unverferth.com/parts/](http://www.unverferth.com/parts/) for the most current parts listing.**

ITEM	PART NUMBER	DESCRIPTION	QTY	NOTES
45	9000104	Cable Tie 21 1/2"	4	
	9000106	Cable Tie 7 1/2"	22	
	9000107	Cable Tie 14 1/2"	8	
46	9003814	Top Plate	6	(NOT SHOWN)
47	9003816	Clamp Pair	6	(NOT SHOWN)
48	9007842	Hose 1/4" x 172" (9/16"-18 JIC Female x 3/4"-16 O-Ring Male)	8	
49	95192	Bulkhead Adapter (9/16"-18 JIC Male x 9/16"-18 JIC Male)	8	
50	288749B	Hydraulic Hose Plate =Black=	1	
51	91256	Flange Screw 5/16"-18UNC x 3/4" Grade 5	2	
52	91257	Hex Nut 5/16"-18UNC Grade 5	2	
53	9005299	Hose 1/4" x 80" (9/16"-18 JIC Female x 9/16"-18 JIC Female)	1	
54	289737B	Cylinder Stop Weldement =Black=	1	
55	289752B	Valve Mount Plate =Black=	1	
56	9002151	Flow Door Control Valve	1	
57	91262	Flange Screw 3/8"-16UNC x 1" Grade 5	3	
58	91263	Large Flange Nut 3/8"-16UNC	3	
59	92927	Adapter (9/16"-18 JIC Male x 3/4"-16 O-Ring Male)	1	
60	93657	Plug (3/4"-16 O-Ring Male)	1	
61	9390-011	Capscrew 1/4"-20UNC x 2 1/2" Grade 5	2	
62	97189	Hex Nut 1/4"-20UNC	2	
63	9390-053	Capscrew 3/8"-16UNC x 3/4" Grade 5	1	
64	9395-006	Hex Jam Nut 3/8"-16UNC	1	
65	97401	Hose 1/4" x 34" (9/16-18 JIC Female Swivel)	1	
66	98508	Adapter 3/4"-16 Male O-Ring x 3/4"-16 Male O-Ring	8	

**EOH Tractor Circuit Hydraulic Components (Optional)**

Please visit [www.unverferth.com/parts/](http://www.unverferth.com/parts/) for the most current parts listing.



ITEM	PART NO.	DESCRIPTION	QTY.	NOTES
1	9002283	Hydraulic Hose, 1/2 x 184" - 3000 PSI	1	
2	9007842	Hydraulic Hose, 1/4 x 172" - 3000 PSI	1	
3	9009765	Hose Grip, Hydraulic Pressure (Tan +)	1	Spout Rotate Rear
4	9009766	Hose Grip, Hydraulic Return (Tan -)	1	Spout Rotate Front
5	9006527	JIC Tube Reducer, 9/16"-18 UNF Male x 9/16"-18 UNF Female	1	
6	91383	Male Tip Coupling, 3/4"-16	2	
7	9006994	Check Line Valve 145 PSI	1	
8	901568	90° Elbow 3/4"-16 JIC Male x 3/4"-16 O-Ring ADJ Male	1	
9	9874	90° Elbow 9/16"-18 JIC Male x 3/4"-16 O-Ring ADJ Male	1	
10	98508	Adapter 3/4"-16 O-Ring Male x 3/4"-16 O-Ring Male	4	
11	9003848	Velcro Hose Wrap, 2" I.D. x 127" Lg.	1	
12	9005403	120 Micron Hydraulic Filter	1	

**EOH Valve Assembly Components 4 Spool (Optional)**

Please visit [www.unverferth.com/parts/](http://www.unverferth.com/parts/) for the most current parts listing.

PUSH BUTTON AND HOLD WHILE OPERATING INDIVIDUAL FUNCTIONS

Cartridge Valve (9008438)

FOR MANUAL OVERRIDE

**NOTE:** Refer to “Manual Override for Optional Electric Over Hydraulic System” in MAINTENANCE section.

**7**

**HYDRAULIC BLOCK MANUAL OVERRIDE OPERATION**

MANUAL OPERATION: DIRECTION OF CARTRIDGE TO DESIRED FUNCTION.  
 PRESS & HOLD THE POWER CARTRIDGE FOR PURSUON.  
 RELEASE POWER AND RETURN CARTRIDGE TO CENTER DETENT WHEN FUNCTION IS COMPLETE

**CAUTION** CARTRIDGES MUST BE IN CENTER DETENT TO PREVENT UNSAUNTED HAUNTON DUNGRES JOYSTICK OPERATIONS

UPPER FUNCTION  
 JOYSTICK OPERATION  
 LOWER FUNCTION  
 SPURGE DETENT

**EOH Valve Assembly Components 4 Spool (Optional)**

**Please visit [www.unverferth.com/parts/](http://www.unverferth.com/parts/) for the most current parts listing.**

ITEM	PART NO.	DESCRIPTION	QTY.	NOTES
1	9008416	Cartridge Valve - 4 Way, 3 Position - Closed Center w/Detented Manual Override	4	
	9003906	Seal Kit	-	
2	9008438	Cartridge Valve - 2 Way, 2 Position w/Push Type Manual Override	1	
	9003904	Seal Kit	-	
3	9001495	Adapter 9/16"-18 JIC Male x 9/16"-18 O-Ring Male	8	
4	9005769	Coil - 12 VDC DN-40	9	
5	9008374	4 Spool Hydraulic Block Assembly	1	
6	9008366	Manifold Block - 4 Spool	1	
7	9009470	Decal, Valve Block Caution	1	



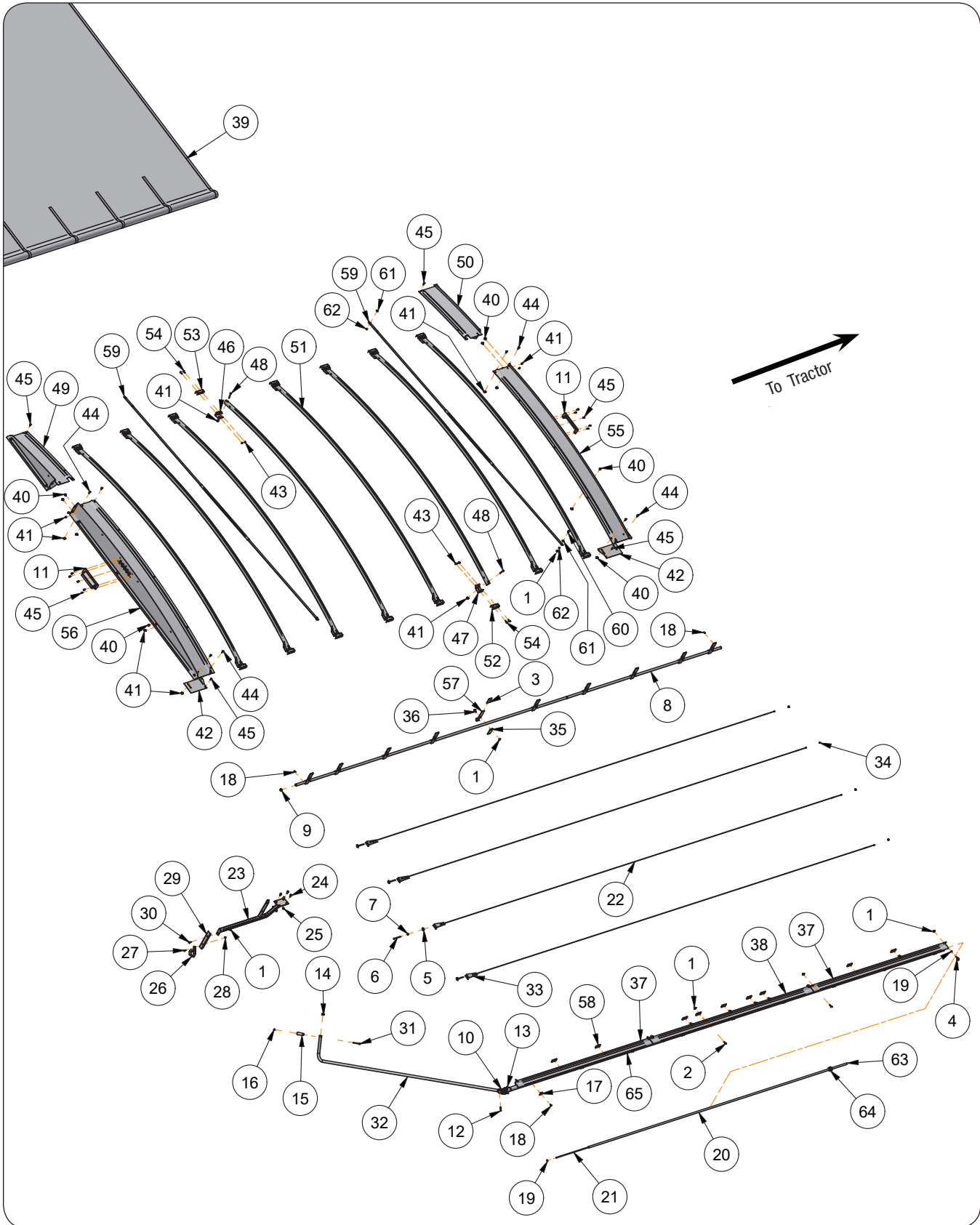
**Electrical**

**Please visit [www.unverferth.com/parts/](http://www.unverferth.com/parts/) for the most current parts listing.**

ITEM	PART NUMBER	DESCRIPTION	QTY	NOTES
1	9007911	Wiring Harness, Front	1	
2A	280847	Tail Light RH Sub Assembly	1	Includes Items 3A, 4 through 12, 13A, 14
2B	280848	Tail Light LH Sub Assembly	1	Includes Items 3B, 4 through 12, 13B, 14
3A	251406B	RH Plate	1	
3B	251407B	LH Plate	1	
4	9005142	LED Light, Amber - Double Face	2	
	9005095	LED Lens Only	-	
5	9003127	Amber Reflector	7	2" x 9"
6	9003126	Red Reflector	2	2" x 9"
7	9003125	Fluorescent Strip, Red-Orange	2	2" x 9"
8	9390-003	Capscrew, 1/4"-20UNC x 3/4"	4	
9	9405-064	Flat Washer, 1/4"	8	
10	9404-017	Lock Washer, 1/2"	8	
11	9394-002	Hex Nut, 1/4"-20UNC	8	
12	9390-009	Capscrew, 1/4"-20 UNC x 2"	4	
13A	292719B	RH Light Bracket Weldment =Black=	1	
13B	292718B	LH Light Bracket Weldment =Black=	1	
14	280370B	Tube, Light =Black=	2	
15	9007921	Clearance Wiring Harness	1	
16	9000104	Cable Tie, 21 1/2"	2	
17	9000106	Cable Tie, 7 1/2"	9	
18	9000107	Cable Tie, 14 1/2"	2	
19	9003397	Locking Flange Nut 1/2"-13UNC	2	
20	9006107	Micro Dot Amber Light (LED)	2	
21	9006282	Red Light- Tail/Turn (LED)	2	
22	9008957	Work Light (LED)	3	Includes Items 23 through 29
23	9390-055	Capscrew 3/8"-16UNC x 1"	1	
24	9405-078	Flat Washer 3/8"	1	
25	9404-021	Lock Washer 3/8"	1	
26	9394-006	Hex Nut 3/8"-16UNC	1	
27	9390-034	Capscrew 5/16"-18UNC x 2"	1	
28	9404-019	Lock Washer 5/16"	1	
29	9394-004	Hex Nut 5/16"-18UNC	1	
30	9007472	Proximity Switch	1	
31	9007913	Wiring Harness, Rear	1	
32	92450	Electrical Coupler	1	
33	9390-112	Capscrew 1/2"-13UNC x 4 1/2"	2	
34	903172-350	Pan Head Machine Screw, #10-32UNF x 1 1/4"	4	
35	9404-013	Split Lock Washer, #10	4	
36	9830-016	Hex Nut #10-32 Grade 2	4	
37	9009077	Wiring Harness - Auger Light 579 15/16"	1	
38	9004981	Lock Washer - External Tooth	1	
39	9390-003	Capscrew 1/4"-20UNC x 3/4"	1	
40	9394-002	Hex Nut 1/4"-20UNC	1	
41	9404-017	Lock Washer 1/4"	1	
42	271574B	Light Bracket =Black=	1	
43	9005312	Truss Head Machine Screw 3/8"-16UNC x 1"	1	
44	91263	Nut/Large Flange 3/8"-16UNC	1	
45	291585	Hydraulic Block Assembly 4 Spool	1	
46	9008403	Harness - Main	1	
47	9006233	Harness - Extension	1	
48	9008402	Harness - Power	1	
49	9008378	L-Series Control Grip - 4 Function	1	

Weather Guard Tarp

Please visit [www.unverferth.com/parts/](http://www.unverferth.com/parts/) for the most current parts listing.



**Weather Guard Tarp**

**Please visit [www.unverferth.com/parts/](http://www.unverferth.com/parts/) for the most current parts listing.**

ITEM	PART NO.	DESCRIPTION	QTY	NOTES
1	91263	Flange Nut 3/8"-16UNC	16	
2	9009089	Machine Screw 3/8"-16UNC x 1 1/4"	3	
3	9003078	Plastic Cap 3/16"x2"x3"	10	
4	9004548	Eye Bolt 3/8"-16UNC x 1 3/4"	1	
5	9005696	Fender Washer 3/8"	4	
6	TA0-907131-0	Cap Screw 3/8"-16UNC x 4 1/2" Grade 5	4	
7	9005688	Lock Washer 3/8"	4	
8	288362	Fixed Tube 1 1/8" x 116 1/2"	1	
9	9005088	Plug 1 1/8"	2	
10	9004977	U-Joint 1 3/8"-21 Spline	1	
11	9009504	End Cap Vent Cover	2	
12	9092-180	Roll Pin 3/8" x 2"	1	
13	9005305	Lynch Pin 3/8" x 3"	1	
14	9005089	Plug 1 1/4"	1	
15	9004969	Handle	1	
16	9398-012	Locknut 3/8"-16UNC	1	
17	9004949	U-Clamp 1 9/16" x 1 1/2"	9	
18	9005197	Self Drilling Screw #10-16 x 3/4"	9	
19	9405-074	Flat Washer 3/8" SAE	2	
20	221668	PVC Pipe	1	
21	221722	Bungee Cord	1	
22	9007866	Cable Assembly 301"	4	
23	256712B	Tarp Crank Holder Weldment =Black=	1	
24	9390-099	Cap Screw 1/2"-13UNC x 1" Grade 5	4	
25	9002058	Flange Nut 1/2"-13 UNC	4	
26	221770B	Handle Retainer Bracket =Black=	1	
27	9390-055	Cap Screw 3/8"-16UNC x 1" Grade 5	1	
28	9928	Lock Nut 3/8"-16UNC	1	
29	265743B	Crank Holder Extension =Black=	1	
30	91262	Flange Screw 3/8"-16UNC x 1" Grade 5	1	
31	903172-450	Pan Head Screw 3/8"-16UNC x 4 1/2"	1	
32	287944	Handle Weldment	1	
33	281712B	Bracket & U-Nut Assembly =Black=	4	
34	9005727	Plug 7/16"	4	
35	295183B	Tarp Stop Plate =Black=	10	
36	9003259	Flange Screw 3/8"-16UNC x 1 1/4"	10	
37	296847	Front and Rear Latch Plate 100 3/16"	2	Replacement kit #297782
38	296848	Middle Latch Plate 119 1/2"	1	

(Continued on next page)



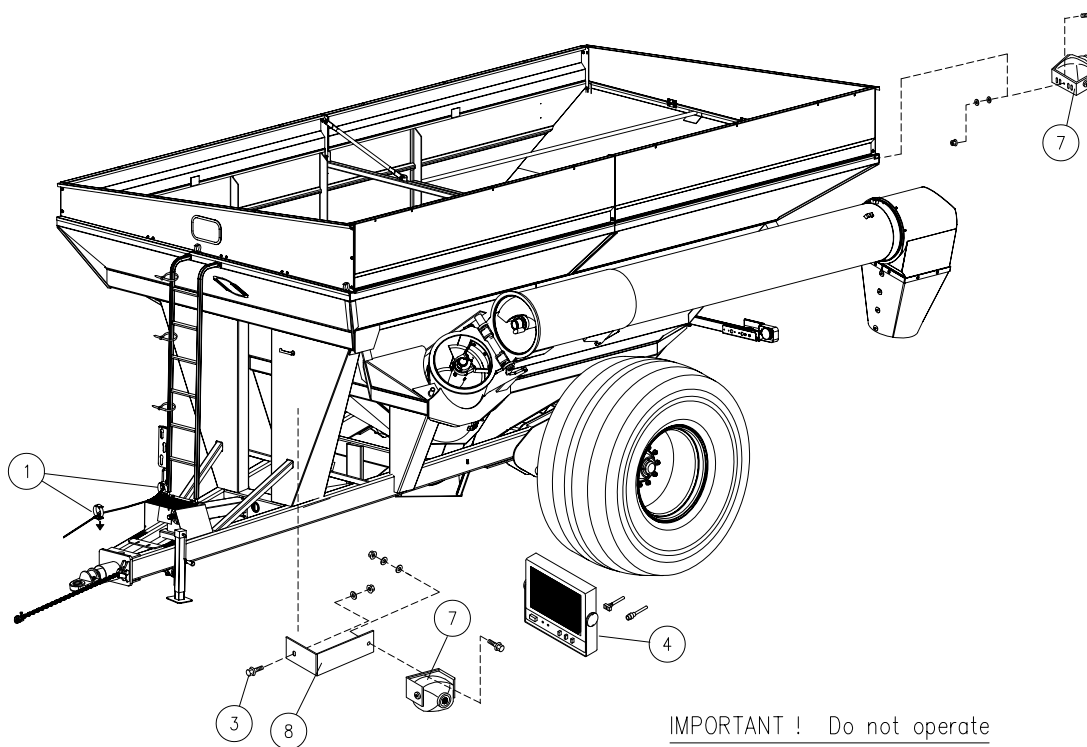
**Weather Guard Tarp (continued)**

**Please visit [www.unverferth.com/parts/](http://www.unverferth.com/parts/) for the most current parts listing.**

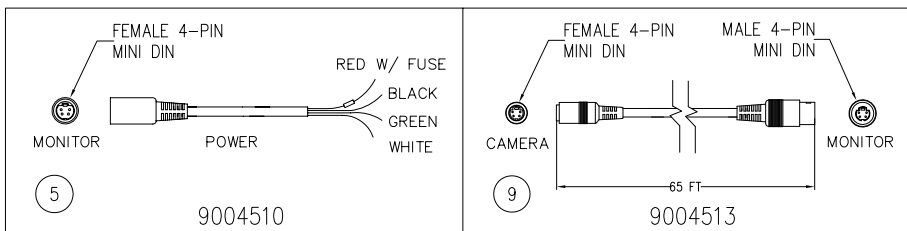
ITEM	PART NO.	DESCRIPTION	QTY	NOTES
39	9007865	Tarp 176" x 314"	1	For V1300
	9008103	Tarp 194" x 314"		For V1500
	9005581	Tarp Repair Kit	-	
40	95585	Flange Screw 3/8"-16UNC x 3/4" Grade 5	16	
41	91263	Flange Nut 3/8"-16UNC	40	
42	283431B	End Cap Plate =Black=	2	
43	91257	Flange Nut 5/16"-18UNC	32	
44	9005312	Truss Head Screw 3/8"-16UNC x 1"	12	
45	9512	Self Drilling Screw 1/4"-14 x 1"	14	
46	283427B	Tarp Bow Bracket LH =Black=	8	
47	283425B	Tarp Bow Bracket RH =Black=	8	
48	902703-046	Socket Cap Screw 3/8"-16 UNC x 3"	16	
49	288343B	End Cap Weldment - Rear - Short =Black=	1	For V1300
	288647B			For V1500
50	288341B	End Cap Weldment - Front - Short =Black=	1	For V1300
	288646B			For V1500
51	288339B	Tarp Bow Tube =Black=	8	For V1300
	288640B			For V1500
52	289986B	Doubler Plate RH =Black=	8	
53	281936B	Doubler Plate LH =Black=	8	
54	97604	Flange Screw 5/16"-18UNC x 1" Grade 5	32	
55	296129B	End Cap Weldment - Front - Long =Black=	1	For V1300
	296757B	End Cap Weldment - Front - Long - Service Kit		For V1300 Includes End Cap & Items 11 & 45
	296142B	End Cap Weldment - Front - Long =Black=	1	For V1500
	296759B	End Cap Weldment - Front - Long - Service Kit		For V1500 Includes End Cap & Items 11 & 45
56	296131B	End Cap Weldment - Rear - Long =Black=	1	For V1300
	296758B	End Cap Weldment - Rear - Long - Service Kit		For V1300 Includes End Cap & Items 11 & 45
	296143B	End Cap Weldment - Rear - Long =Black=	1	For V1500
	296760B	End Cap Weldment - Rear - Long - Service Kit		For V1500 Includes End Cap & Items 11 & 45
57	266689B	Tarp - Short Stop =Black=	10	
58	295259B	Tarp Spacer Plate =Black=	8	
59	9008948	Hurricane Strap 12 FT Wide Hopper	2	
60	96972	Screw/Self Tapping 3/8"-16UNC x 1"	2	
61	9008972	Flat Washer, 3/8" Aluminum	4	
62	9008949	Tarp Strap Spacer Bushing	4	
63	TA806225	Hose 1/2" EPDM	1	
64	9004947	Tube End Plug 2"	1	
65	288360	Roll Tube Weldment	1	

**Video System Option**

**Please visit [www.unverferth.com/parts/](http://www.unverferth.com/parts/) for the most current parts listing.**



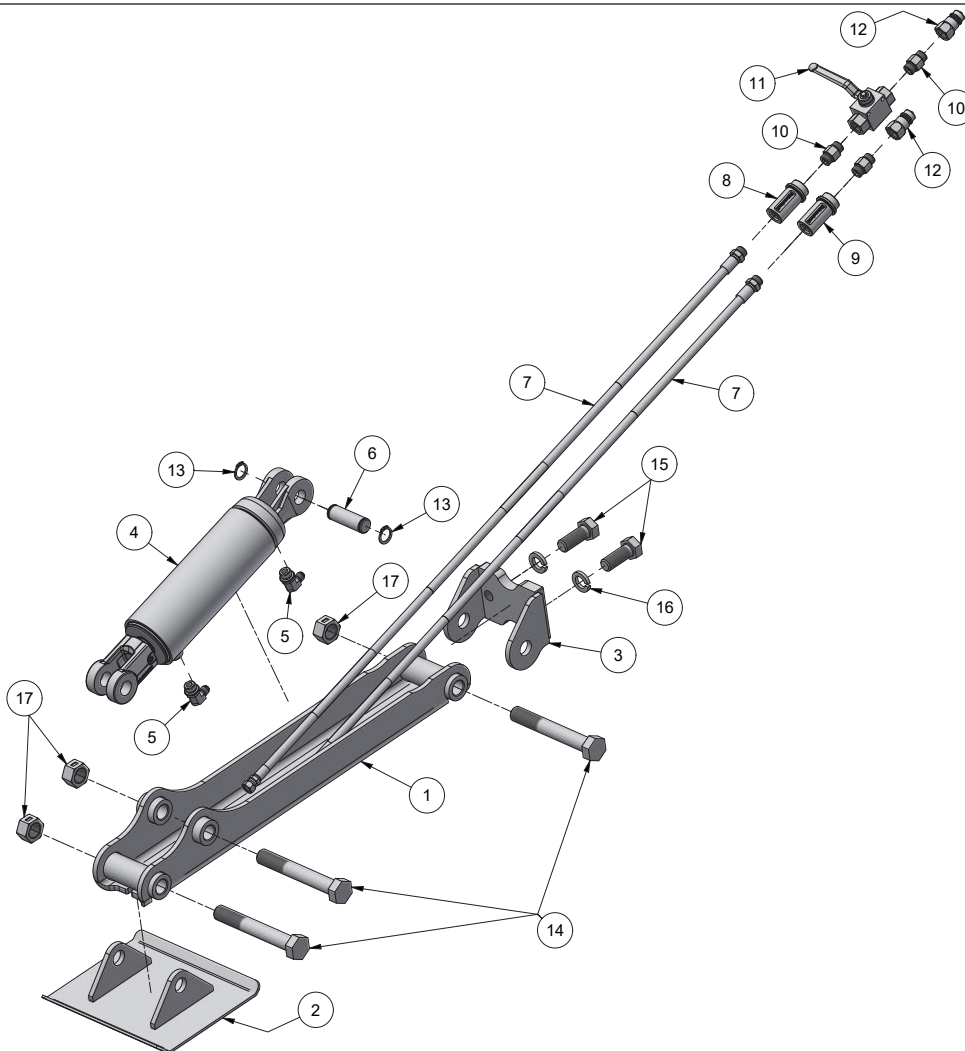
**IMPORTANT ! Do not operate Video System below 15° F.**



ITEM	PART NUMBER	DESCRIPTION	QTY	NOTES
	265770	Video System Kit for Front View	1	Includes Items 1,3,4,5,6,7,8
	9004506	Additional Camera for Rear View	1	Includes Items 6 & 7
1	TAAU14007	Snap Clip, Adhesive	10	
3	9512	Self-Drilling Screw 1/4-14 x 1	10	
4	9006273	Monitor, 7" LCD/LED	1	
5	9004510	Cable w/Fuse	1	
7	9006274	Camera	1	
8	265771B	Bracket	1	
9	9004513	Cable, 65'	1	
10	9000106	Cable Tie	AR	
11	9004506	Camera Kit for Rear View with 65' Cable	1	Not Shown
12	9007174	Camera Cable, 16 ft.	1	Not Shown

**Hydraulic Jack - Kit #294143B (Optional)**

Please visit [www.unverferth.com/parts/](http://www.unverferth.com/parts/) for the most current parts listing.



ITEM	PART NO.	DESCRIPTION	QTY	NOTES
1	271712B	Jack Weldment =Black=	1	
2	271723B	Jack Foot Weldment =Black=	1	
3	273808B	Jack Mount Weldment =Black=	1	
4	9009047	Hydraulic Cylinder 3 1/2" x 8"	1	
5	9006173	90° Elbow Fitting 9-16" FO x 3/4" O-Ring Male	2	
6	272587	Cylinder Pin 1" Dia. x 3 1/8"	1	
7	9006068	Hydraulic Hose 1/4" x 92"	2	
8	9009757	Hose Grip, Raise Jack (Black +)	1	
9	9009758	Hose Grip, Lower Jack (Black -)	1	
10	98508	Adapter 3/4"-16 Male O-Ring x 3/4"-16 Male O-Ring	3	
11	9005426	Ball Valve	1	
12	91383	Tip Coupling 3/4"-16 O-Ring Female Threads	2	
13	91192	Retaining Ring, 1"	2	
14	9390-197	Capscrew 1"-8UNC x 7" Grade 5	3	
15	9390-165	Capscrew 7/8"-9UNC x 2 1/4" Grade 5	2	
16	9404-037	Lock Washer 7/8"	2	
17	92199	Lock Nut 1"-8UNC	3	

**Notes**

**Please visit [www.unverferth.com/parts/](http://www.unverferth.com/parts/) for the most current parts listing.**

